

The background is a watercolor painting. It features a central silhouette of a person standing, rendered in shades of orange and brown. The background is composed of various washes of blue, green, and brown. In the foreground, there are dark green, leafy branches that appear to be climbing or growing across the scene.

The Gernert Company

Foreign Rights Guide
Spring 2022



By turns suspenseful, hilarious, powerful, and moving, these are three of the greatest stories John Grisham has ever told.

Doubleday - May 31, 2022

From the #1 New York Times bestselling author:
Three novellas that prove beyond a shadow of a doubt
that John Grisham is truly America's Favorite Storyteller.

John Grisham's books have sold more than 350 million copies across 46 languages and have been made into 10 blockbuster films.

"Homecoming" takes us back to Ford County, the fictional setting of many of John Grisham's unforgettable stories. Jake Brigance is back, but he's not in the courtroom. He's called upon to help an old friend, Mack Stafford, a former lawyer in Clanton, who three years earlier became a local legend when he stole money from his clients, divorced his wife, filed for bankruptcy, and left his family in the middle of the night, never to be heard from again—until now. Now Mack is back, and he's leaning on his old pals, Jake and Harry Rex, to help him return. His homecoming does not go as planned.

In "Strawberry Moon," we meet Cody Wallace, a young death row inmate only three hours away from execution. His lawyers can't save him, the courts slam the door, and the governor says no to a last-minute request for clemency. As the clock winds down, Cody has one final request.

The "Sparring Partners" are the Malloy brothers, Kirk and Rusty, two successful young lawyers who inherited a once prosperous firm when its founder, their father, was sent to prison. Kirk and Rusty loathe each other, and speak to each other only when necessary. As the firm disintegrates, the resulting fiasco falls into the lap of Diantha Bradshaw, the only person the partners trust. Can she save the Malloys, or does she take a stand for the first time in her career and try to save herself?

Beginning with *The Firm*, **John Grisham** has written at least one #1 bestseller every year. He is the author of thirty-seven novels, one work of nonfiction, a collection of stories and seven novels for young readers. He is a two-time winner of the Harper Lee Prize for Legal Fiction and was distinguished with the Library of Congress Creative Achievement Award for Fiction.

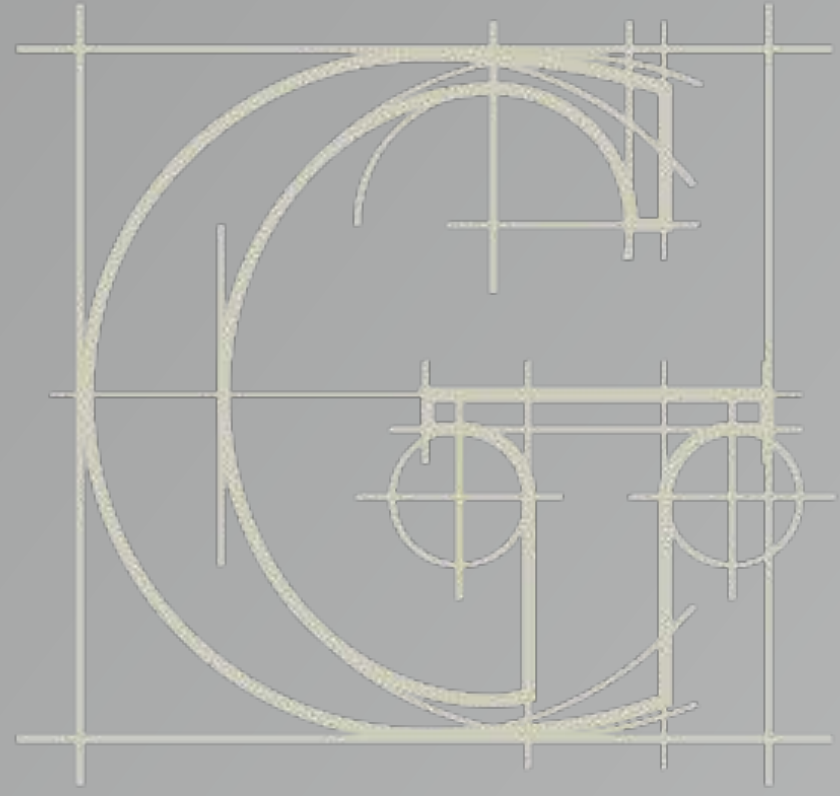

the
gernert
company

Coming Soon
Publications



A singular, cosmically charged journey through art, memory, and the ways our lives intertwine and align within the riddles of space and time.

Knopf - May 17, 2022

Debut novel sold to Knopf at auction • Sold in 5 foreign territories

- Quotes from Nathan Hill, Anna Weiner, Charles Yu and more

“The Red Arrow feels like a book that’s gently tapping on your brain from a different dimension. It’s an astonishing portrait of a distressed mind searching for peace and hope and harmony, and finding it in the most sublime of places. Deeply insightful and often hilarious, it’s a dazzling head-trip of a novel, and a profound delight.”—**Nathan Hill, author of *The Nix***

“The Red Arrow is hypnotic, heartbreaking, and shot through with a fierce, determined joy. William Brewer has a talent for dark comedy, and for the sort of defamiliarization that can make one feel somehow more attuned and alive. A beautiful trip through a world made new.”—**Anna Wiener, author of *Uncanny Valley***

literary | metaphysical | dark humor

Rights sold: UK & BC (John Murray Press), The Netherlands (Spectrum), Germany (Blessing Verlag), Japan (Hayakawa), Poland (Czarne)

When a once-promising young writer agrees to ghostwrite a famous physicist’s memoir, his livelihood is already in jeopardy: Plagued by debt, he’s grown distant from his wife and is haunted by an overwhelming sense of dread he describes as “The Mist.” Then, things get worse: The physicist vanishes, leaving everything in limbo, including our narrator’s sanity. Desperate for relief, he undergoes an experimental, psychedelic treatment and finds his world completely transformed. For the first time, he understands himself in a larger, universal context, and feels his life shift, refract, and crack open to reveal his past and future alike. Moving swiftly from a chemical spill in West Virginia to Silicon Valley, from a Brooklyn art studio to a high-speed train racing across the Italian countryside, *The Red Arrow* wades into the shadowy depths of the human psyche only to emerge, as if speeding through a mile-long tunnel, into a world that is so bright and wondrous, it almost feels completely new.

William Brewer is the author of *I Know Your Kind*, a winner of the National Poetry Series. His work has appeared in *The New Yorker*, *The Nation*, and *The Best American Poetry* series. A former Wallace Stegner Fellow, he is a Jones Lecturer at Stanford University. He lives in Oakland.

Editor: Jordan Pavlin | Agent: Chris Parris-Lamb | Material: 2nd pass pages

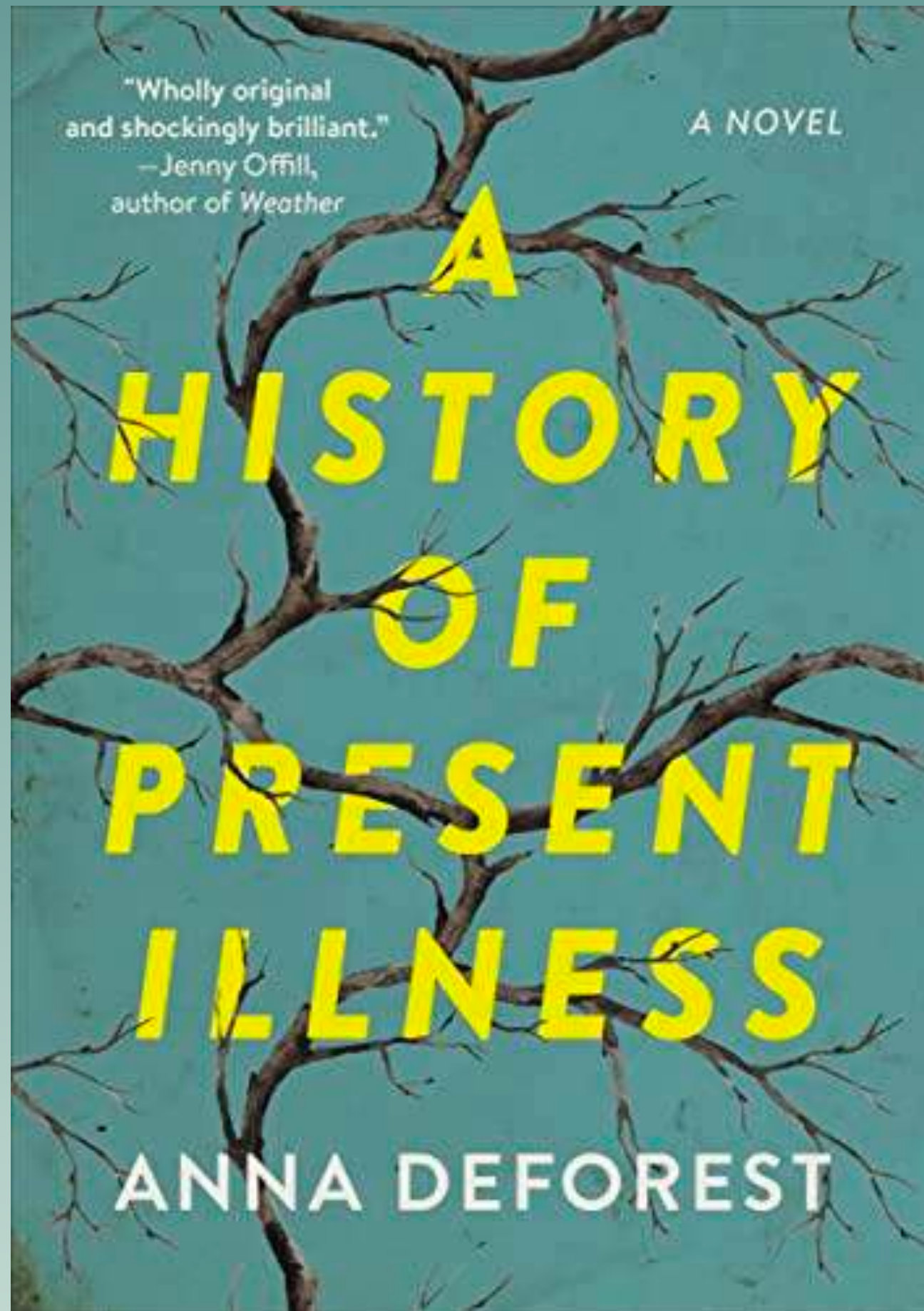

A novel of meticulous brevity with a tone and vision all its own, transmuting the practice of medicine into a larger exploration of humanity, the meaning of care, and the nature of annihilation—physical, spiritual, or both.

Little Brown - August 16, 2022

A striking, meditative debut novel by a practicing neurologist • sold to Little, Brown at auction

"*A History of Present Illness* is a singular read, full of beauty and wit and monstrous truth. It took me down dark corridors of loss and out into the too bright sunshine again. I've never read anything like it. Wholly original and shockingly brilliant."—**Jenny O'Fallon, author of *Weather***

"Nowhere else have I ever encountered such brutal wisdom—about life, about the body, about our shared circumstance as the future dead—delivered with such grace, such largeness of heart. Anna DeForest's fearless, unsparing debut is a life raft thrown out for all of us to cling to."—**Garielle Lutz, author of *The Complete Gary Lutz***

This book destroyed my heart, and then restored it. The raw eloquence of the language, the wisdom spiked with gallows humor, the young woman who transcends an early life of damage—the tension and triumph come from how easily the narrator's life could have gone the other way."—**Amy Hempel, author of *The Collected Stories***

literary fiction | *medicine* | *family*

A young woman puts on a white coat for her first day as a student doctor. So begins this powerful debut, which follows our unnamed narrator through cadaver dissection, surgical rotation, difficult births, sudden deaths, and a budding relationship with a seminarian. In the troubled world of the hospital, where the language of blood tests and organ systems so often hides the heart of the matter, she works her way from one bed to another, from a man dying of substance use and tuberculosis, to a child in pain crisis, to a young woman, fading from confusion to aphasia to death. The long hours and heartrending work begin to blur the lines between her new life as a physician and the lifelong traumas she has fled.

In brilliant, wry, and biting prose, *A History of Present Illness* is a boldly honest meditation on the body, the hope of healing in the face of total loss, and what it means to be alive.

Anna DeForest is a neurologist and palliative care physician in New York City. Her writing has appeared in the *Alaska Quarterly Review*, the *Journal of the American Medical Association*, the *New England Journal of Medicine*, and the *Paris Review*. This is her first novel.

fiction

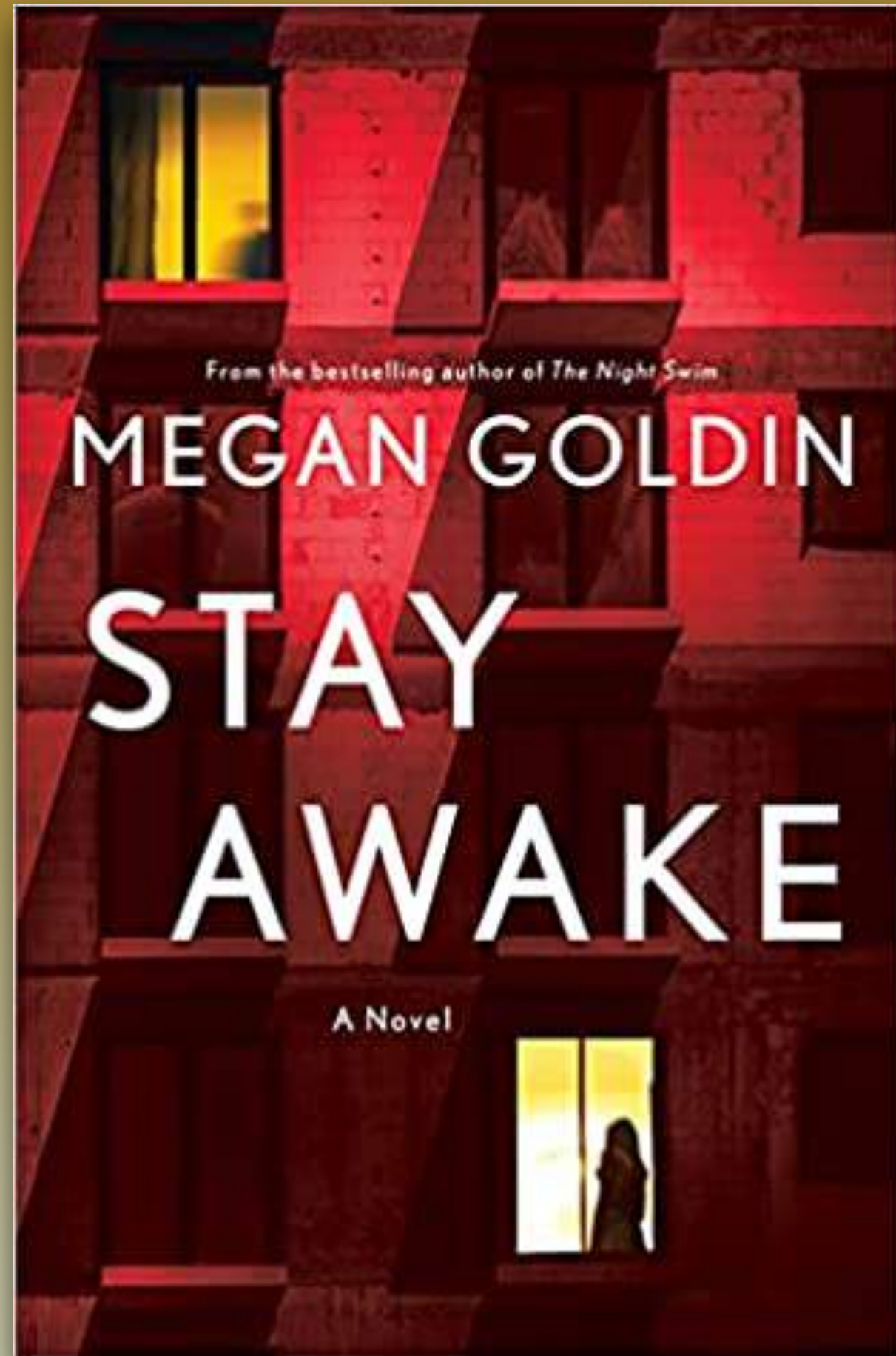

A complex thriller that unfolds at breakneck speed, Stay Awake will keep you up all night.

St. Martins Press - August 9, 2022

In the vein of S.J. Watson's *Before I Go To Sleep* and Christopher Nolan's *Memento*, an electrifying novel of memory and murder

Praise for Megan Goldin:

"Goldin's prose is inviting, at times electrifying, and always sensitive in dealing with hot-button issues...well done."—**Booklist, starred review for *The Night Swim***

"Outstanding.... [Goldin's thriller] casts a searing light on small-town politics.."—**Publishers Weekly, starred review for *The Night Swim***

"High wire tension from the first moment to the last. Four ruthless people locked in a deadly game where victory means survival. Gripping and unforgettable!"
—**Harlan Coben on *The Escape Room***

Thriller* | *insomnia* | *memory

Rights sold: UK&BC (Canelo Crime), Australia/New Zealand (Penguin Books)

Liv Reese wakes up in the back of a taxi with no idea where she is or how she got there. When she's dropped off at the door of her brownstone, a stranger answers - a stranger who now lives in her apartment and forces her out in the cold. She reaches for her phone to call for help, only to discover it's missing, and in its place is a bloodstained knife. That's when she sees that her hands are covered in black pen, scribbled messages like graffiti on her skin: STAY AWAKE. Two years ago, Liv was living with her best friend, dating a new man, and thriving as a successful writer for a trendy magazine. Now, she's lost and disoriented in a New York City that looks nothing like what she remembers. Catching a glimpse of the local news, she's horrified to see reports of a crime scene where the victim's blood has been used to scrawl a message across a window, the same message that's inked on her hands. What did she do last night? And why does she remember nothing from the past two years? Liv finds herself on the run for a crime she doesn't remember committing as she tries to piece together the fragments of her life. But there's someone who does know exactly what she did, and they'll do anything to make her forget - permanently.

Megan Goldin, author of *The Escape Room* and *The Night Swim*, worked as a correspondent for Reuters and other media outlets where she covered war, peace, international terrorism and financial meltdowns. She is now based in Melbourne, Australia where she raises three sons and is a foster mum to Labrador puppies learning to be guide dogs.

Editor: Charlie Spicer | Agent: David Gernert | Material: 2nd pass pages

fiction

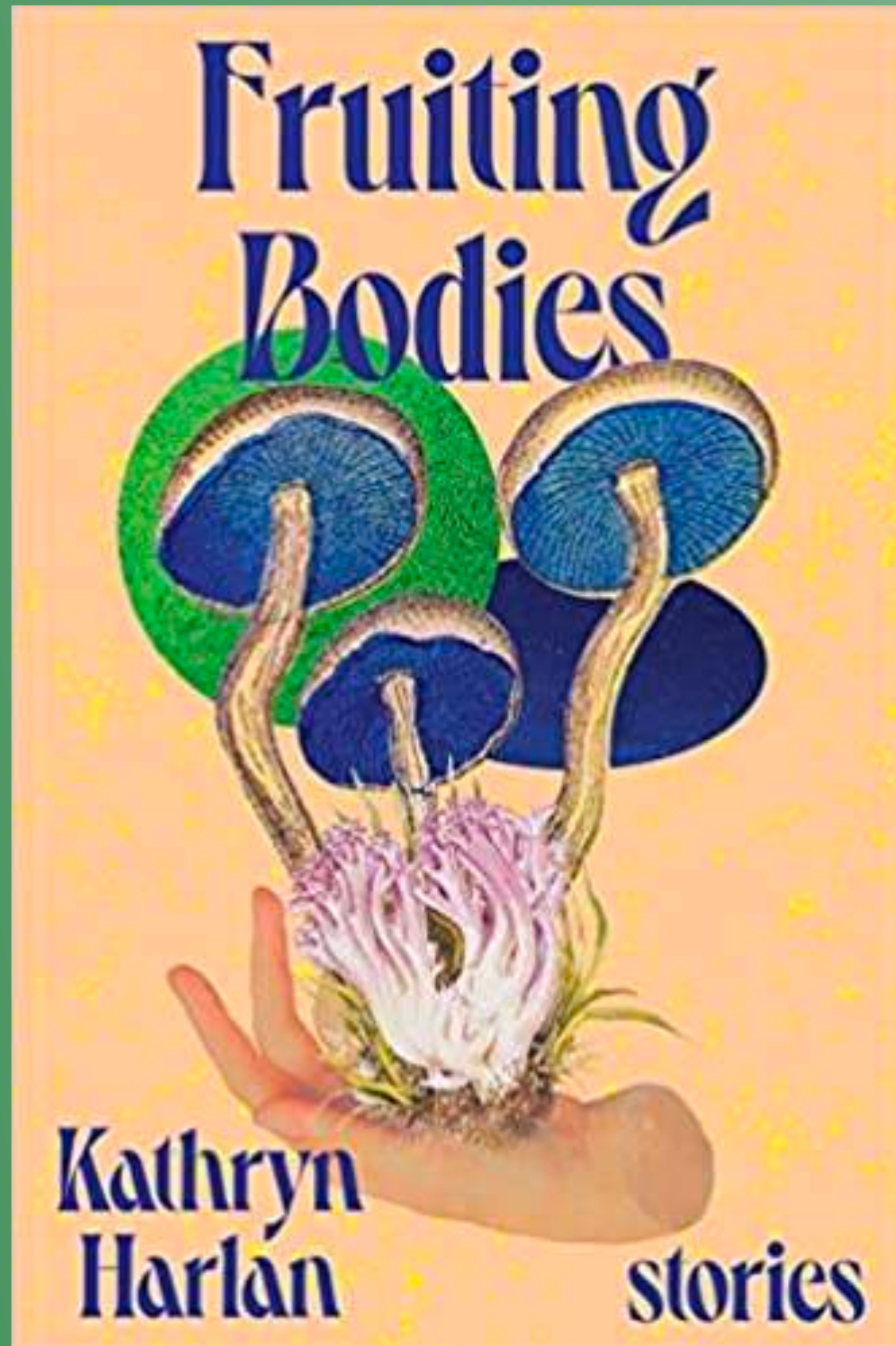

For readers of Carmen Maria Machado and Karen Russell
a debut collection of genre-bending stories

“A debut of astonishing range and beauty, nimble and magical and profound. In stunning prose, Kathryn Harlan’s wildly imaginative and daring stories reveal the anguish of growing up in a dying world. Her characters’ quest for knowledge - about themselves, their families, their bodies, and their yearnings - will thrill and haunt you.”

—**Jessamine Chan**, author of *The School for Good Mothers*

“These excellent stories are insightful, transporting, and gloriously uncanny. In story after story, *Fruiting Bodies* uncovers knowledge that is tantalizing and terrible.”

—**Kirstin Valdez Quade**, author of *The Five Wounds*

short stories | *lgbtq+* | *literary fiction*

In stories that beckon and haunt, *Fruiting Bodies* ranges confidently from the fantastical to the gothic to the uncanny, as it follows characters—mostly queer, mostly women—on the precipice of change. In “The Changeling,” two young cousins wait in dread for a new family member to arrive, convinced that he may be a dangerous supernatural creature. In “Endangered Animals,” Jane prepares to say goodbye to her almost-love while they road-trip across a country irrevocably altered by climate change. In the title story, partners Agnes and Geb feast peacefully on the mushrooms that sprout from Agnes’s body—until an unwanted male guest disturbs their cloistered home.

Fruiting Bodies offers stories about knowledge in a world on the verge of collapse, knowledge that alternately empowers or devastates. Pulling beautifully, brazenly, from a variety of literary traditions, Kathryn Harlan firmly establishes herself as a thrilling new voice in fiction.

Kathryn Harlan is a fiction writer with an MFA from the University of Wisconsin-Madison. She was born and raised in California, but now lives in Wisconsin and teaches at UW-Madison. She has also been a teaching artist for the Loft Literary Center. Her work is forthcoming in *The Colorado Review*, and has previously appeared in the *Michigan Quarterly Review*, *The Gettysburg Review*, and *Strange Horizons*.

This genre-bending collection of stories constructs eight eerie worlds full of desire, wisdom, and magic blooming amidst decay.

W.W. Norton - June 7, 2022

Editor: Jill Bialosky | Agent: Meredith Kaffel Simonoff | Material: 1st pass pages

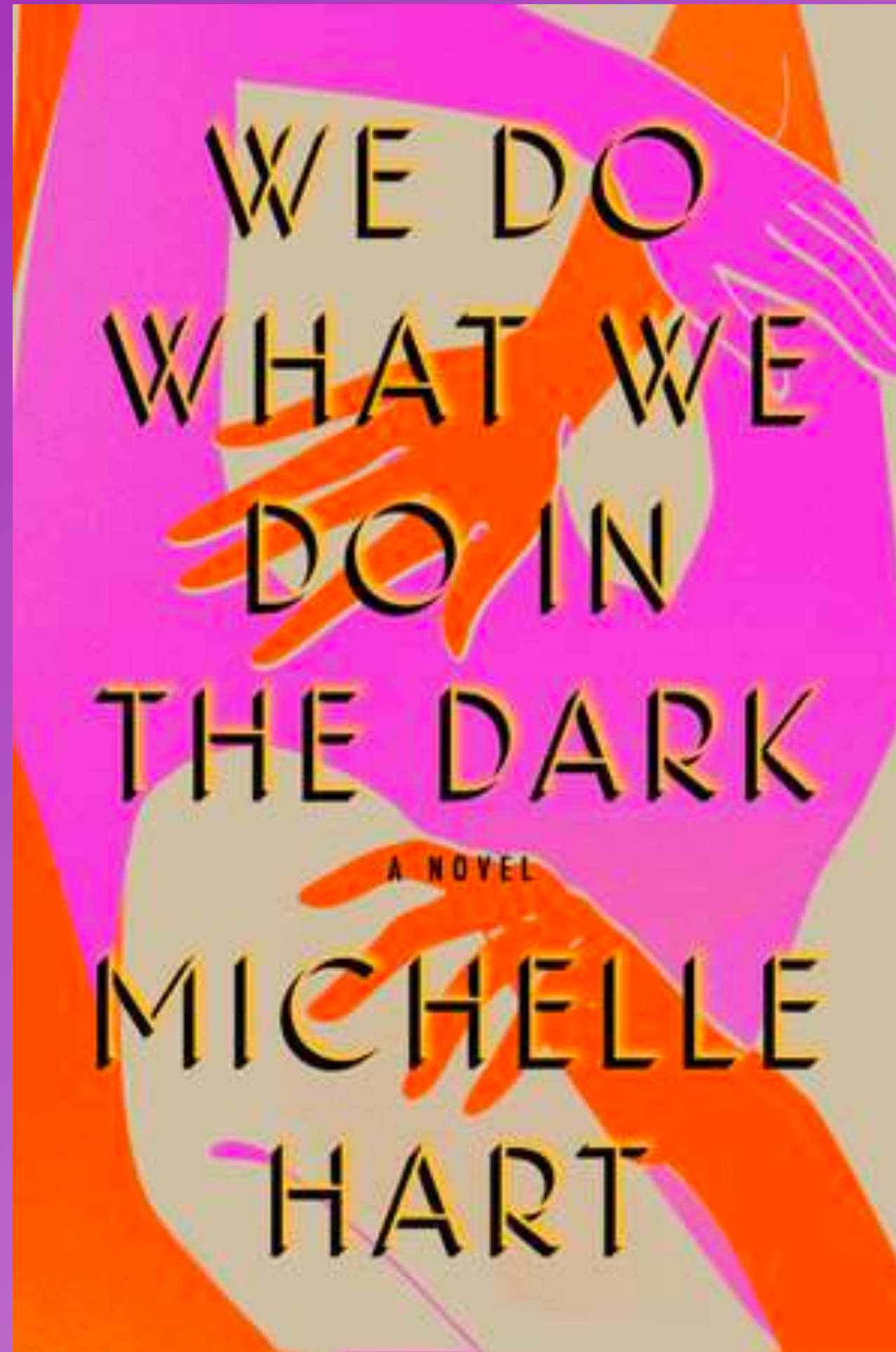

A novel about a young woman's life-altering affair with a much older, married woman.

Riverhead - May 3, 2022

UK deal with Tinder Press at auction

- Blurbs from Meg Wolitzer, Tayari Jones and Torrey Peters
 - Riverhead lead title with extensive marketing and promotion
-

"Michelle Hart's first novel is a haunting study of solitude and connection, moving and memorable."—**Meg Wolitzer, author of *The Female Persuasion* and *The Interestings***

"A gorgeous storyteller, Hart is gifted with a poet's precision, blending image and idea. Sensual and wise, this novel channels the melancholic exhilaration of dangerous love."
—**Tayari Jones, author of *An American Marriage***

"A beautiful book so filled with sharp longing and perfectly phrased vulnerability that I read it in a reverent hush."—**Torrey Peters, author of *Detransition, Baby***

literary | *coming of age* | *queer*

Rights sold: UK & BC (Tinder Press)

Mallory is a freshman in college, reeling from her mother's recent death, when she encounters the woman. She sees her for the first time at the university's gym, immediately entranced. Soon, they meet, drawn by an electric tension and shared past wounds; before long, they begin sleeping together in secret. Self-possessed, successful, brilliant, and aloof—the woman is everything Mallory wants...and wants to be. Desiring not only the woman but also the idea of who she is when they're together, Mallory retreats from the rest of the world, solidifying a sense of aloneness that has both haunted and soothed her since childhood and will continue to do so for years even after the affair ends. As an adult, Mallory must decide whether to stay safely in isolation or step fully into the world, to confront what the woman meant to her and how their relationship shaped her, for better or worse. In this enthralling debut novel, the complexities of influence, obsession, and admiration reveal how desire and its consequences can alter the trajectory of someone's life.

Michelle Hart is the Assistant Books Editor at *O, the Oprah Magazine*. Her fiction has appeared in *Joyland* and *Electric Literature*, and she has written nonfiction for *Catapult*, *Nylon*, the *Rumpus*, and *The New Yorker* online. She received her M.F.A. in Fiction from Rutgers University-Newark.

fiction



From the award-winning author of the story collection VOLT comes an American myth of the future: a vision of civil war, spectacle, and disaster of biblical proportions.

MCD/FSG - August 2, 2022

A haunting and bold debut novel, from the recipient of a Whiting and National Magazine Award

Praise for Alan Heathcock and *Volt*

“Heathcock displays a generosity of spirit that only those writers who love their characters can summon, and *Volt* is galvanizing proof of his talent.”—***The New York Times Book Review***

“Misery is in plentiful supply in these dark, thickly atmospheric tales of spiritual desolation and savagery. Fans of William Gay and Daniel Woodrell will savor these stories where sin and suffering shroud the hope of redemption.”—***Publishers Weekly, starred review***

dystopian | *science fiction* | *mythic*

In a future America ravaged by natural disaster, pandemic, and political unrest, a fundamentalist religious faction emerges. As the Chosen gain power, enticing civilians with bread and circuses, a civil war breaks out between its members and the US government. But Mazzy Goodwin, a young soldier, only wants to find her little sister, Ava Lynn. One day, she wakes in a bomb crater to find wings sprouting from her back. The world sees a miracle. But Mazzy is coaxed into seeing it as an opportunity: to become the angel-like figurehead of the revolution, in return for being reunited with her sister. Her journey leads her to New Los Angeles, where the Chosen have set up the headquarters for their propaganda machine—right in the ruins of Hollywood. Aided by friends old and new, she must navigate a web of deceit while staying true to herself.

Told in sharp, haunting prose, as cinematic as it is precise, Alan Heathcock’s *40* is a dizzyingly fantastical novel about the dangers of blind faith, the temptation of spectacle, and the love of family. In a tale by turns mythic and tragic, one heroine must come to terms with the consequences of her decisions—and face the challenges of building a new world.

Alan Heathcock is the author of the short story collection *Volt*, published by Graywolf Press in 2011. His work has appeared in *Zoetrope: All-Story*, *The Virginia Quarterly Review*, *The Kenyon Review*, and *Best American Mystery Stories*, among other places. He is the winner of a National Magazine Award in fiction.

Editor: Sean McDonald | *Agent:* Sarah Burnes | *Material:* 1st pass pages

fiction

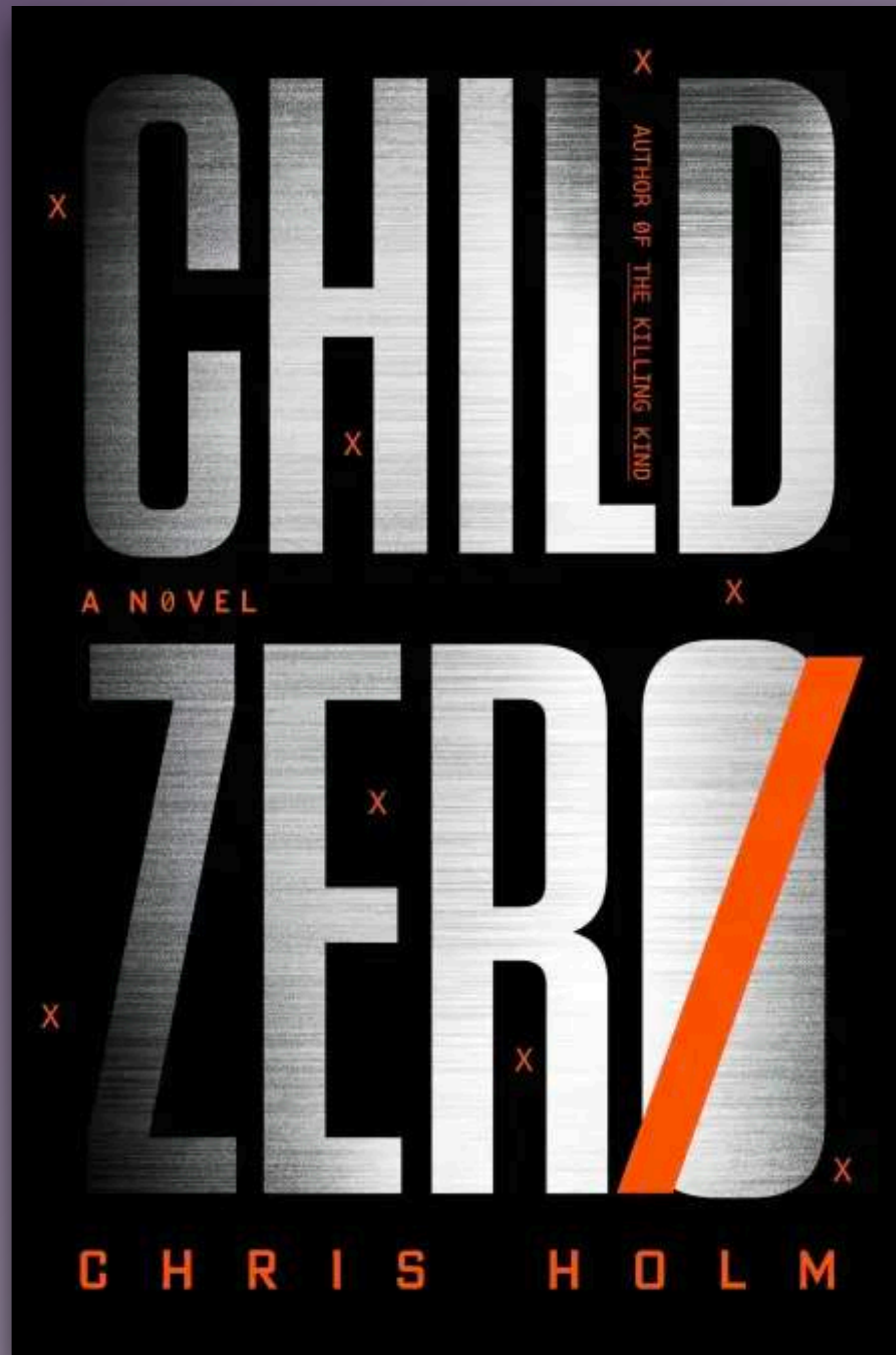

From molecular biologist turned Anthony Award-winning author of The Killing Kind comes a fact-based thriller about our species' next great existential threat.

A gripping technothriller from an Anthony Award winner in the vein of Michael Crichton • blurbs from Lee Child and Tess Gerritsen

"Intense, propulsive, provocative - and shot through with the kind of been-there, done-that authenticity and expertise that makes it really scary.... Highly recommended."

—**Lee Child, #1 New York Times bestselling author of *Better Off Dead***

"*Child Zero* is a thriller that truly thrills! With warp-speed pacing and frightening medical details, it offers a terrifying look at a world gone mad and the possible plagues to come."

—**Tess Gerritsen, New York Times-bestselling author of *Listen to Me***

post-apocalyptic | *thriller* | *speculative fiction*

It began four years ago with a worldwide uptick of bacterial infections: meningitis in Frankfurt, cholera in Johannesburg, tuberculosis in New Delhi. Although the outbreaks spread aggressively and proved impervious to our drugs of last resort, public health officials initially dismissed them as unrelated. They were wrong. Antibiotic resistance soon roiled across the globe. Diseases long thought beaten came surging back. The death toll skyrocketed. Then New York City was ravaged by the most heinous act of bioterror the world had ever seen, perpetrated by a new brand of extremist bent on pushing humanity to extinction. Detective Jacob Gibson, who lost his wife in the 8/17 attack, is home caring for his sick daughter when his partner summons him to a sprawling shantytown in Central Park, the apparent site of a mass murder. Jake is startled to discover that, despite a life of abject squalor, the victims died in perfect health—and his only hope of finding answers is a twelve-year-old boy on the run from some very dangerous men.

Chris Holm is the author of the cross-genre Collector trilogy, the Michael Hendricks thrillers, and thirty-odd short stories in a variety of genres. His work has been selected for THE BEST AMERICAN MYSTERY STORIES, named a *New York Times* Editors' Choice, appeared on more than fifty year's best lists, and won a number of awards, including the 2016 Anthony Award for Best Novel. He lives in Portland, Maine.

fiction



A woman returns to her small Maine hometown, uncovering family secrets that take her on a journey of self-discovery and new love, in this warm and charming novel.

Ballantine - June 14, 2022

From the *New York Times* bestselling author of *Evvie Drake Starts Over* that sold in 18 territories • a BookPage Most Anticipated Book of 2022

women's fiction | *humor/uplifting* | *romance*

Rights sold: UK & BC (Hodder)

Smarting from her recently canceled wedding and about to turn forty, Laurie Sassalyn returns to her Maine hometown of Calcasset to handle the estate of her great-aunt Dot, a spirited adventurer who lived to be ninety-three. Alongside boxes of Polaroids and pottery, a mysterious wooden duck shows up at the bottom of a cedar chest. Laurie's curiosity is piqued, especially after she finds a love letter to the never-married Dot that ends with the line "And anyway, if you're ever desperate, there are always ducks, darling." Laurie is told that the duck has no financial value. But after it disappears under suspicious circumstances, she feels compelled to figure out why anyone would steal a wooden duck—and why Dot kept it hidden away in the first place. Suddenly Laurie finds herself swept up in a righteous caper that has her negotiating with antiques dealers and con artists, going on after-hours dates at the local library, and reconnecting with her oldest friend and her first love. Desperate to uncover her great-aunt's secrets, Laurie must reckon with her own past and her future—and ultimately embrace her own vision of flying solo.

With a cast of unforgettable characters and a heroine you will root for from page one, *Flying Solo* is a wonderfully original story about growing up, coming home, and learning to make a life for yourself on your own terms.

Linda Holmes is a novelist, a pop culture correspondent for NPR, and one of the hosts of the popular podcast *Pop Culture Happy Hour*, which has held sold-out live shows in New York, Los Angeles, Washington, D.C., and elsewhere. She appears regularly on NPR radio shows including *Morning Edition*, *All Things Considered*, and *Weekend Edition*. Her first novel, *Evvie Drake Starts Over*, was a *New York Times* bestseller.

Editor: Sara Weiss | Agent: Sarah Burnes | Material: 1st pass pages

fiction

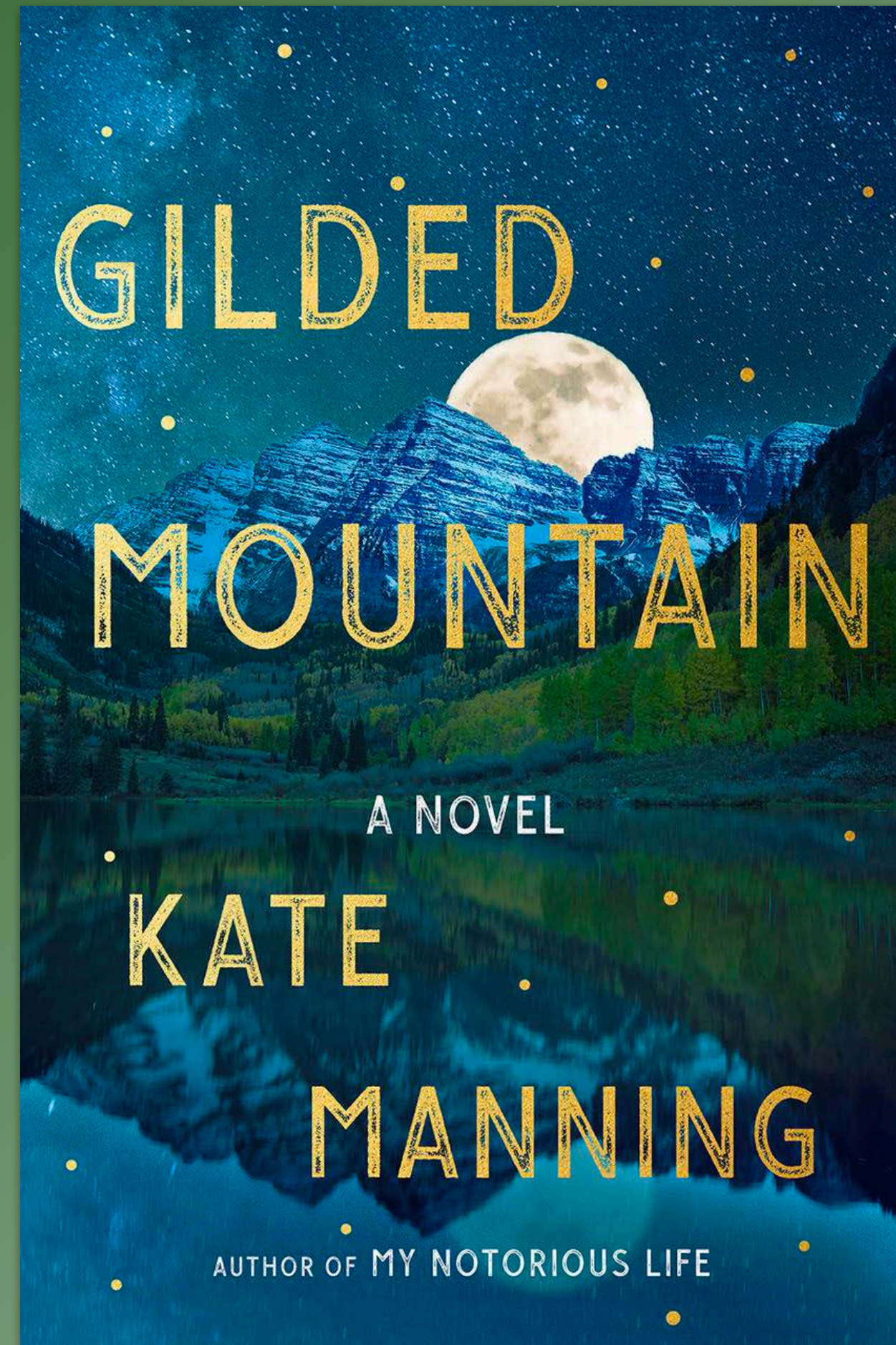

Sylvie Pelletier is the irrepressible young heroine of this sweeping historical novel, set in Moonstone, Colorado, 1907. Hers is the tale of a hardscrabble education, about right and wrong, and the consequences of speaking out against injustice.

Scribner - November 1, 2022

A powerful saga about resilience from the acclaimed author of *My Notorious Life* •
Lead title for Scribner

Praise for Kate Manning and *My Notorious Life*

“Manning paints a vivid portrait of this daring yet deeply compassionate woman who is willing to flout convention and defy the law in the name of women’s reproductive rights... it’s the details of Madame X’s private life, told in her thick Irish brogue—about the search for her long-lost siblings, her fiery relationship with her devoted husband, and her growth as a mother—that lend a human face to a this sensational figure.”—***Publishers Weekly, starred review***

“Not just a splendidly page-turning story of an angry orphan clawing her way up in the world, but a gripping docu-drama about women’s business (in several senses) in nineteenth-century America.”
—***Emma Donoghue, author of ROOM***

historical | *literary* | *American west*

In a voice full of questions and sly humor, Sylvie recounts the story of leaving her family’s snowbound mountain cabin to work in the local manor house for the Padgetts, owners of the marble mining company that employs her father and dominates the town. Sharp-eyed Sylvie is awed by the luxury around her, fascinated by her employer, the charming “Countess” Inge, and confused by the erratic affections of Jasper, the bookish heir to the family fortune. When she learns that a European King will soon arrive for a hunting party, her fairy-tale ideas of glamour and romance take a dark turn, as she realizes the Padgetts’ lofty philosophical talk is at odds with the unfair labor practices that have enriched them. Their servants, the Gradys, descendants of formerly enslaved people have long known this to be true—and are making plans to form a utopian community on the Colorado prairie.

Drawn from true stories of Colorado history, *Gilded Mountain* is an unforgettable saga of a bygone American West seized by robber barons and settled by immigrants; a novel about resilience in the midst of hardship, and a story infused with longing—for family and equality, beauty and joy.

Kate Manning is the author of the critically acclaimed novels *My Notorious Life* and *Whitegirl*. A former documentary television producer and winner of two Emmy Awards, she has written for *The New York Times*, *The Washington Post*, the *Los Angeles Times Book Review*, *Time*, *Glamour*, and *The Guardian*, among other publications. She has taught creative writing at Bard High School Early College in Manhattan, and lives with her family in New York City.

Editor: Kara Watson | Agent: Sarah Burnes | Material: 1st pass pages

fiction

THE GOD OF GOOD LOOKS: A Novel

Breanne Mc Ivor



In the vein of Jane Austen and Candice Carty-Williams, a debut novel about a Trinidadian woman who finds herself assisting a legendary makeup artist.

Morrow - Spring/Summer 2023

Mc Ivor's short story collection was shortlisted for the Commonwealth Prize among other nominations • Sold at auction for healthy six figures

Praise for Breanne Mc Ivor and *Where There Are Monsters*:

"*Where There Are Monsters* is a beguiling collection of short stories, well-placed and paced, involving characters whose flaws and complexities haunt you, long, long after you're done."—**Marsha Massiah-Aaron, founder/director of the Brooklyn Caribbean Literary Festival**

"Crisp tales with memorable characters—men as well as women—who hold varying positions in the race/class structure, set in contemporary Trinidad, but with periodic irruptions of folkloric beliefs from other eras. A brisk and enjoyable read."—**New West Indian Guide**

upmarket fiction | *Caribbean* | *beauty*

Bianca Bridge is at her wit's end. Fired from her editorial job after scandalizing Trinidad's conservative society with an affair with a married government minister, Eric Hugo, she's struggling to make ends meet. With nothing left to lose, Bianca agrees to assist the brilliant but aloof makeup artist Obadiah Cortland who is not the elite tyrant he seems. He's clawed part-way up society's ladder and built OC Beauty around his meticulously crafted persona. Bianca and Obadiah work diligently together, while Trinidadian high society throws obstacles in their path. When Bianca discovers Obadiah's unexpected connection to her former lover, and the power Eric Hugo is continuing to attempt to wield over her and the OC Beauty community she's come to love, she's finally ready to fight back like her mother taught her — and to reconsider, at last, the nature of what might deserve to be called beautiful. *The God of Good Looks* alternates between Bianca's irreverent, yet poignant diary entries and Obadiah's clear-eyed first person narrative as it captures the fraught impact of the commodification of beauty in a patriarchal society, the Caribbean's rigid class barriers, and the sweet ache of two young people seeking to find their voice.

Breanne Mc Ivor's writing has been shortlisted for the Commonwealth Short Story Prize, the Glimmer Train Fiction Open, the BCLF Elizabeth Nunez Award for Writers in the Caribbean, and the Derek Walcott Writing Prize. Her short story collection, *Where There Are Monsters*, was published in 2019 by Peepal Tree Press. She lives in West Trinidad.

Editor: Liz Stein | Agent: Meredith Kaffel Simonoff | Material: Submission manuscript

fiction

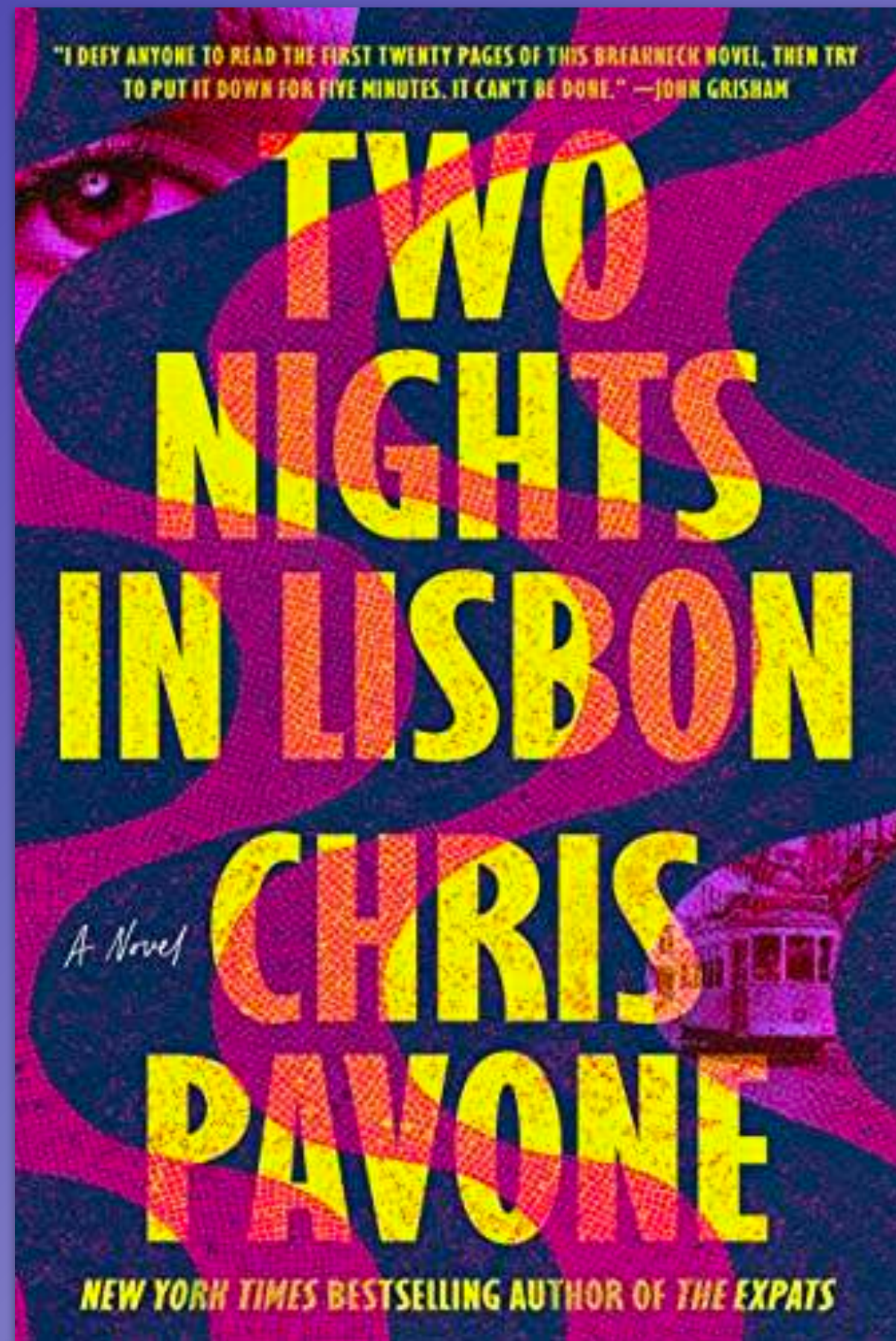

Tautly wound and expertly crafted, a riveting thriller about a woman under pressure, and how far she will go when everything is on the line.

MCD/FSG - May 24, 2022

Author of *The Expats* and two more *New York Times* bestselling thrillers •
Previous books licensed in twenty territories • New relationship with FSG

“I defy anyone to read the first twenty pages of this breakneck novel, then try to put it down for five minutes. This is smart suspense at its very best.”

—**John Grisham**

“There’s no such thing as a book you can’t put down, but this one was close.”—**Stephen King**

“*Two Nights in Lisbon* is sensationally good—timely, important, layered with ticking suspense, driven by an ominous drumbeat that accelerates like a panicked heart. My thriller of the year so far.”

—**Lee Child**

“Weaving together hairpin Hitchcockian suspense and true moral heft, Chris Pavone’s *Two Nights in Lisbon* is his best yet—utterly timely and brimming over with surprise, nuance, cunning, and a palpable weight.”—**Megan Abbott**

international | *thriller* | *suspense*

Rights sold: UK & BC (Head of Zeus), France (Gallimard), Portugal (Lua de Papel)

Ariel Price wakes up in Lisbon, alone. Her husband is gone—no warning, no note, not answering his phone. Something is wrong. She starts with hotel security, then the police, then the American embassy, at each confronting questions she can’t fully answer: What exactly is John doing in Lisbon? Why would he drag her along on his business trip? Who would want to harm him? And why does Ariel know so little about her new—much younger—husband? The clock is ticking. Ariel is increasingly frustrated and desperate, running out of time, and the one person in the world who can help is the one person she least wants to ask. With sparkling prose and razor-sharp insights, bestselling author Chris Pavone delivers a stunning and sophisticated international thriller that will linger long after the surprising final page.

Chris Pavone is author of four international thrillers: *THE EXPATS* (2012), *THE ACCIDENT* (2014), *THE TRAVELERS* (2016), and *THE PARIS DIVERSION* (2019). Chris's novels have appeared on the bestseller lists of the *New York Times*, *USA Today*, *Wall Street Journal*, *Washington Post*, *Chicago Tribune*, and *IndieNext*; have won both the *Edgar* and *Anthony* awards, and have been shortlisted for the *Strand*, *Macavity*, and *Los Angeles Times Book Prize*; are in development for film and television; and have been translated into two dozen languages.

Editor: Daphne Durham | Agent: David Gernert | Material: 1st pass pages

fiction

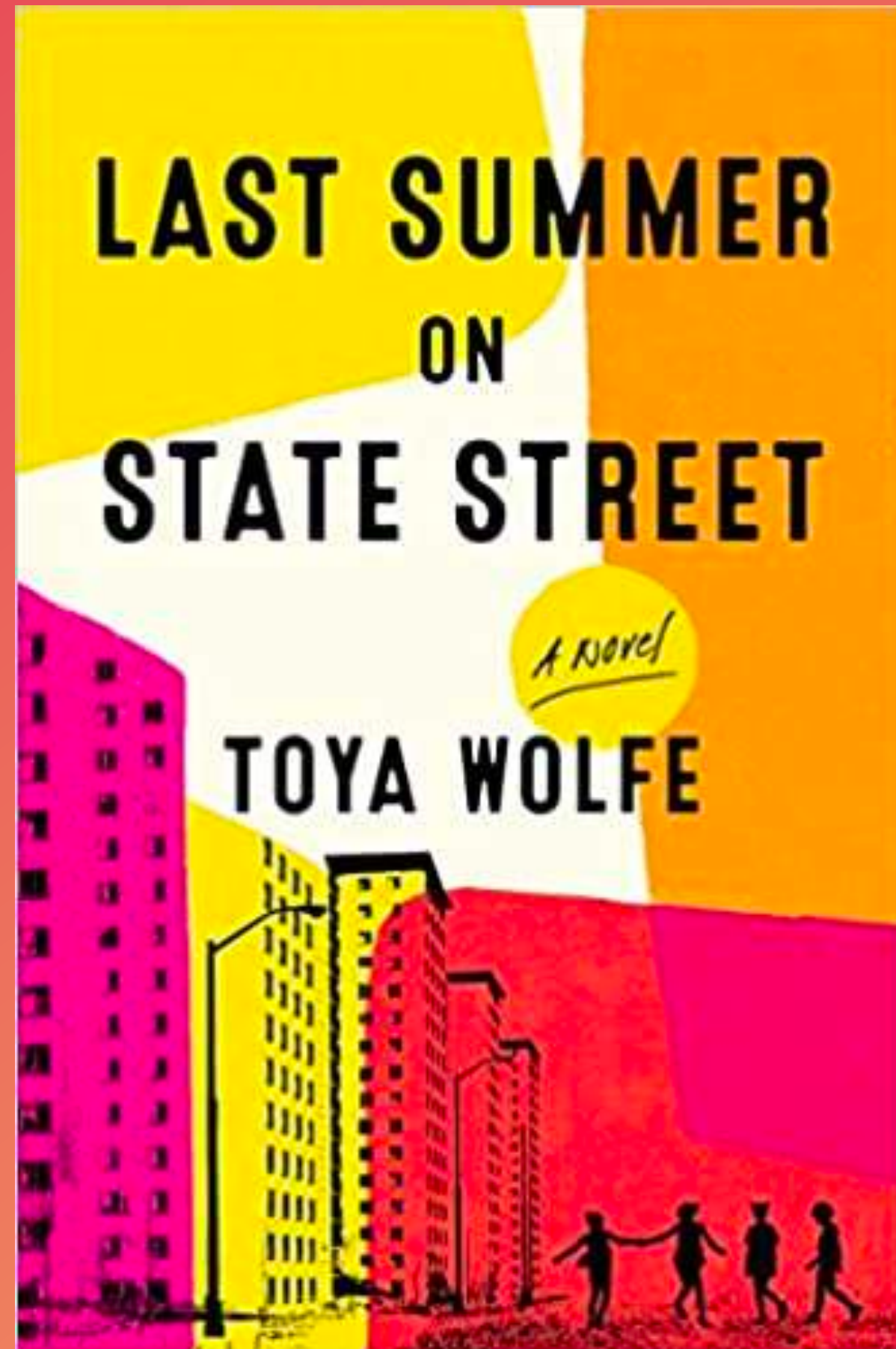

A striking coming-of-age debut about friendship, community, and resilience.

William Morrow - June 14, 2022

For fans of Jacqueline Woodson and Brit Bennett, a debut novel set in the housing projects of Chicago during one life-changing summer.

*“Last Summer on State Street is a triumph, a beautiful ode to the humanity, complexity, and compassion of people in a community too often defined by pathologies. You will root for the brave and surefooted Felicia, Precious, Stacia, and Tonya, as well as their families—all striving amid the rubble. What a lovely debut told with warmth, grace, and a piercing affection.”—Dawn Turner, author of *Three Girls from Bronzeville**

*“Last Summer on State Street is a beautifully observed portrait of family and female friendship. Toya Wolfe is a marvelous writer; her deft storytelling and keen understanding makes her debut novel a great pleasure to read.”—Audrey Niffenegger, *New York Times* bestselling author of *The Time Traveler’s Wife**

coming of age | *female friendship* | *heartfelt*

Rights sold: UK & BC (#Merky)

Felicia “Fe Fe” Stevens is living with her vigilantly loving mother and older teenaged brother, whom she adores, in building 4950 of Chicago’s Robert Taylor Homes. It’s the summer of 1999, and her high-rise is next in line to be torn down by the Chicago Housing Authority. She, with the devout Precious Brown and Stacia Buchanan, daughter of a Gangster Disciple Queen-Pin, form a tentative trio and, for a brief moment, carve out for themselves a simple life of Double Dutch and innocence. But when Fe Fe welcomes a mysterious new friend, Tonya, into their fold, the dynamics shift, upending the lives of all four girls. As their beloved neighborhood falls down around them, so too do their friendships and the structures of the four girls’ families. Fe Fe must make the painful decision of whom she can trust and whom she must let go. Decades later, as she remembers that fateful summer—just before her home was demolished, her life uprooted, and community forever changed—Fe Fe tries to make sense of the grief and fraught bonds that still haunt her and attempts to reclaim the love that never left.

Toya Wolfe grew up in the Robert Taylor Homes on Chicago’s South Side. She earned an MFA in Creative Writing at Columbia College Chicago. Her writing has appeared in *African Voices*, *Chicago Journal*, *Chicago Reader*, *Hairtrigger* 27, and *Warpland: a journal of Black Ideas*. She is the recipient of the Zora Neale Hurston-Bessie Head Fiction Award, the Union League Civic & Arts Foundation Short Story Competition, and the Betty Shifflet/John Schultz Short Story Award. *Last Summer on State Street* is her debut novel.

Editor: Liz Stein | Agent: Meredith Kaffel Simonoff | Material: 1st pass pages

non-fiction

OUT OF YOUR MIND: The Biggest Mysteries of the Human Brain

Jorge Cham and Dwayne Godwin



*An introductory journal into the human brain—
if your inner voice had a PhD in brain science,
made jokes, and drew cartoons.*

Pantheon - Fall 2023

A fun, illustrated journey into the human brain by acclaimed authors and scientists Jorge Cham and Dwayne Godwin

• Preempted by Pantheon for six figures

Praise for Jorge's other works

"You'll laugh and wince at Jorge Cham's smart comic strip"—**USA Today**

"Jorge Cham's comics started out as just another way for a grad student—himself—to procrastinate. Now he's helping millions of others do the same."—**The New York Times**

pop-science | *illustrated* | *humor*

Rights sold: Turkey (Indigo Kitap)

Why do you love? Why do you lie? What makes you happy? Every single thought you have comes from one place: your brain. It is simultaneously the most complex structure we have ever encountered, and it's the very same structure we use to study it. But what makes it tick? How does its intricate wiring affect our everyday lives? How much of it have we decoded, and how much remains an impenetrable mystery? Join popular online cartoonist Jorge Cham (*PHD Comics*; *We Have No Idea*; *Daniel and Jorge Explain the Universe*) and Neuroscientist Dwayne Godwin (*Wake Forest University*; *Scientific American*) on a deep dive into the fascinating world of human brain studies. With casual, clear and jargon-free explanations, compelling stories, and hilarious comics, Jorge and Dwayne will explore interesting questions like, "Where is you in the brain?" "Do we have free will?" "What is consciousness?" and "What makes us happy?" while illuminating everything we know (and DON'T know) about the brain.

Jorge Cham is the creator of the popular online comic *Piled Higher and Deeper*, also known as *PHD Comics*. He earned his PhD in robotics at Stanford.

Dwayne Godwin is a Professor in the Department of Neurobiology and Anatomy and the Dean of the Wake Forest University Graduate School for Biomedical Sciences.

Editor: Denise Oswald | Agent: Seth Fishman | Material: Proposal

non-fiction

DEPORTED: The Hidden Toll of American Expulsion

Caitlin Dickerson



From an Atlantic staff writer and award-winning investigative reporter, the definitive book to address the American deportation system.

NA rights sold, at auction, in a seven figure deal • Dickerson is a staff writer at the Atlantic and a Peabody-winning journalist

sociology | human narrative | systematic inequality

Deportation is a system that pervades every aspect of American life, yet remains largely invisible. In popular discourse, it is treated as a discrete event affecting one person at a single time; in fact, the devastating ripple effect of deportation has a closer analogue in the destabilization felt by millions of Black American households when their sons and fathers are swept into our mass incarceration system. The households of deported immigrants, as well as those who live with the daily fear of expulsion, have been grappling with a similar reality on a massive and under recognized scale.

DEPORTED will be the definitive book to address the complexity and complicity of the American deportation system. Following the people caught in the middle of the system, it is a multi-generational story that spans cities, suburbs, and farmland and knits together an entire continent. Dickerson will reveal how the “deportation machine” has grown largely unchecked into both a multibillion dollar industry and a powerful lobbying force behind harsher policies designed to further increase profits. The narrative centers on the millions of “essential workers” we rely on every day to to pick and serve our food, to clean and build our houses, to care for our children and our elders. At its heart, DEPORTED asks: how did we come to subjugate an entire population living alongside us to a permanent lower class? What harms have resulted, and how can we begin to repair them?

Caitlin Dickerson is a staff writer at the *Atlantic* where she covers immigration and the American experience. She joined the *Atlantic* after five years at the *New York Times*, where she broke news about changes in deportation and detention policy and its consequences. She also served as a frequent guest and guest-host for “The Daily.” Dickerson is the winner of a Peabody and Edward R Murrow Award and three-time finalist for the Livingston Award. She lives in Brooklyn.



A gripping memoir on friendship, grief, the search for self, and the solace that can be found through art.

A bracing memoir from a New Yorker staff writer • Sold to Doubleday in a major deal at auction

memoir | coming of age | grief

In the eyes of 18-year-old Hua Hsu, the problem with Ken—with his passion for Dave Matthews, Abercrombie & Fitch, and his fraternity—is that he is *exactly* like everyone else. Ken, whose Japanese American family has been in the United States for generations, is mainstream; for Hua, the son of Taiwanese immigrants, who makes 'zines and haunts Bay Area record shops, Ken represents all that he defines himself in opposition to. The only thing Hua and Ken have in common is that, however they engage with it, American culture doesn't seem to have a place for either of them.

But despite his first impressions, Hua and Ken become friends, a friendship built of late-night conversations over cigarettes, long drives along the California coast, and the textbook successes and humiliations of everyday college life. And then violently, senselessly, Ken is gone, killed in a carjacking, not even three years after the day they first meet.

Determined to hold on to all that was left of one of his closest friends—his memories—Hua turned to writing. *Stay True* is the book he's been working on ever since. A coming-of-age story that details both the ordinary and extraordinary, *Stay True* is a bracing memoir about growing up, and about moving through the world in search of meaning and belonging.

Hua Hsu is a staff writer at *The New Yorker* and an associate professor of English at Vassar College. Hsu serves on the executive board of the Asian American Writers' Workshop. He was formerly a fellow at the New America Foundation and the Dorothy and Lewis B. Cullman Center at the New York Public Library. He lives in Brooklyn, New York with his family.

non-fiction

Second in a major 3-book deal with Riverhead • Millions of copies of Randall's previous book sold worldwide • #1 New York Times Bestseller

Praise for Randall Munroe and *What If?*

"Extreme astrophysics and indecipherable chemistry have rarely been this clearly explained or this consistently hilarious." —**Entertainment Weekly** "10 Best Nonfiction Books of the Year"

"Consistently fascinating and entertaining...Munroe leavens the hard science with whimsical touches... An illuminating handbook of methods of reasoning." —**Wall Street Journal**

comics | *trivia* | *popular science*

Rights sold: UK & BC (John Murray Press), China (United Sky), Czech Republic (Prah), The Netherlands (Spectrum), German (Penguin Verlag), Hungary (Athenaeum), Italy (Bompiani), Japan (Hayakawa), Korea (Sigongsa), Poland (Czarina Owca), Romania (Publica), Slovakia (Ikar), Sweden (Volante), Taiwan (Commonwealth)

The millions of people around the world who read and loved *What If?* still have questions, and those questions are getting stranger. Thank goodness *xkcd* creator Randall Munroe is here to help. Planning to ride a fire pole from the moon back to Earth? The hardest part is sticking the landing. Hoping to cool the atmosphere by opening everyone's freezer door at the same time? Maybe it's time for a brief introduction to thermodynamics. Want to know what would happen if you rode a helicopter blade, built a billion-story building, made a lava lamp out of lava, or jumped on a geyser as it erupted? Okay, if you insist. Before you go on a cosmic road trip, feed the residents of New York City to a T. rex, or fill every church with bananas, be sure to consult this practical guide for impractical ideas. Unfazed by absurdity, Randall consults the latest research on everything from swing-set physics to airplane-catapult design to clearly and concisely answer his readers' questions. As he consistently demonstrates, you can learn a lot from examining how the world might work in very specific extreme circumstances.

Randall Munroe is the author of the #1 *New York Times* bestsellers *How To*, *What If?* and *Thing Explainer*, the science question-and-answer blog *What If?*, and the popular web comic *xkcd*. A former NASA roboticist, he left the agency in 2006 to draw comics on the internet full time. He lives in Massachusetts.

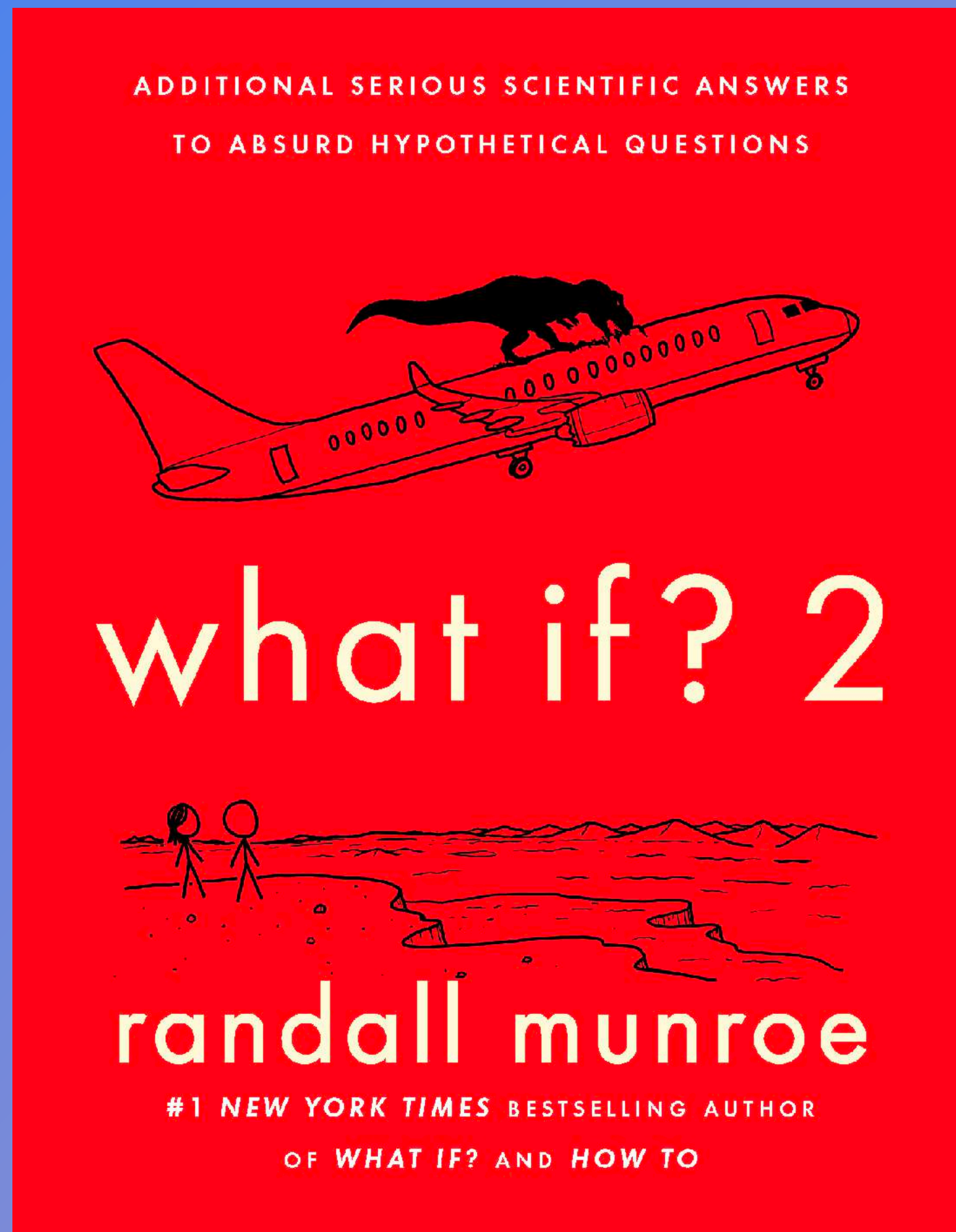

*The #1 New York Times bestselling author of *What If? and How To* provides his best answers yet to the weirdest questions you never thought to ask*

Riverhead - September 13, 2022

Editor: Courtney Young | Agent: Seth Fishman | Material: 1st pass pages

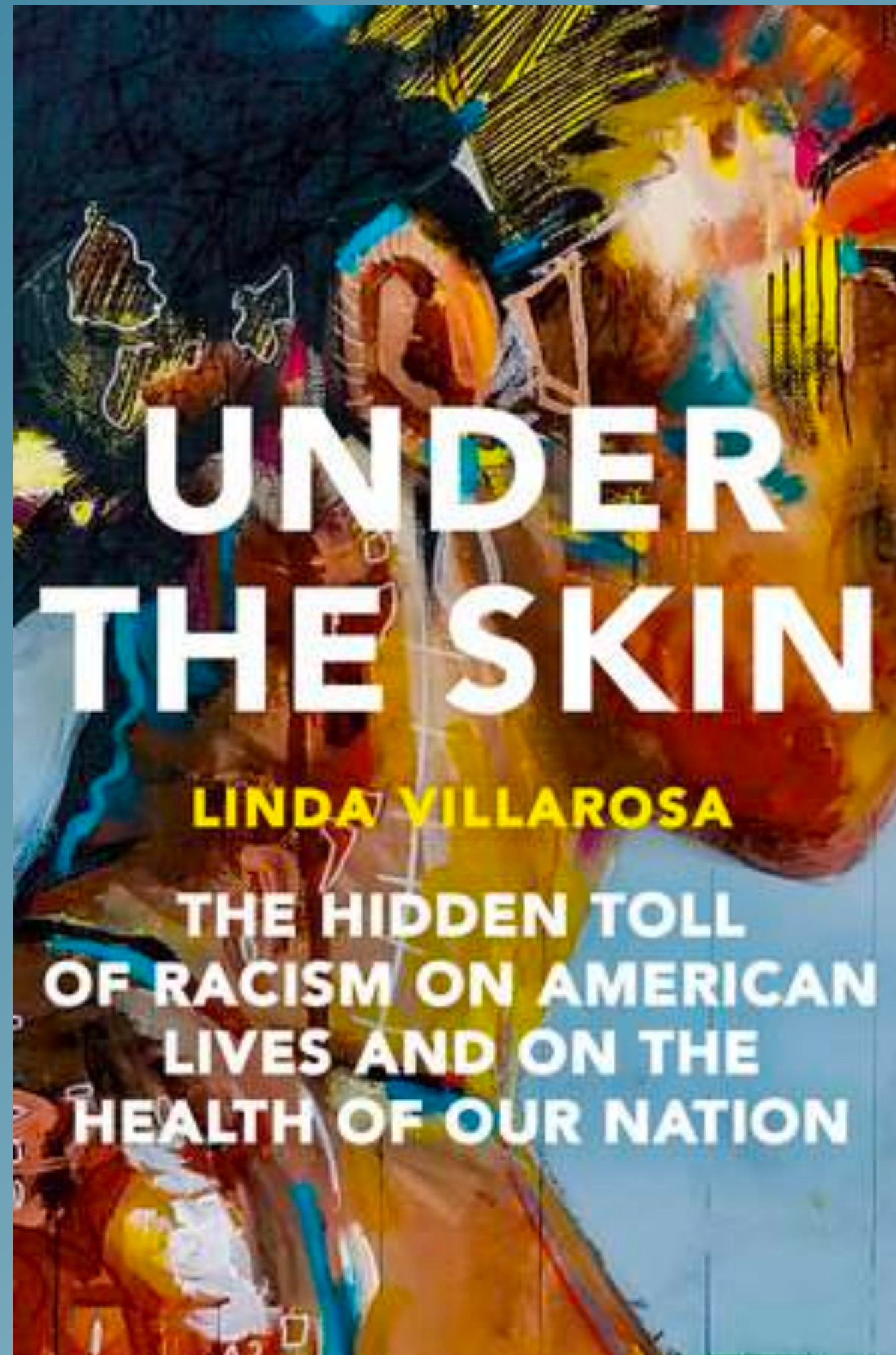

A landmark book that tells the full story of racial health disparities in America, that reveals the toll racism takes on individuals and the health of the nation.

Doubleday - June 14, 2022

From an award-winning writer at the *New York Times Magazine* and a contributor to *The 1619 Project* • Sold in a seven-figure deal to Doubleday at auction • UK/BC rights to Scribe

“Linda Villarosa, one of our fiercest and most cutting-edge journalists, has given us a classic for the ages. Through engrossing stories of people’s real experiences and her signature rigorous reporting, she reveals the biggest picture in American life—that racism has done us all in, and produced a nation so steeped in white supremacy mythology that we cannot take care of ourselves or each other.” — **Sarah Schulman, author of *Let the Record Show***

health policy | *racial disparities* | *journalism*

Rights sold: UK & BC (Scribe)

In 2018, Linda Villarosa’s *New York Times Magazine* article on maternal and infant mortality among black mothers and babies in America caused an awakening. Hundreds of studies had previously established a link between racial discrimination and the health of Black Americans, with little progress toward solutions. But Villarosa’s article exposing that a Black woman with a college education is as likely to die or nearly die in childbirth as a white woman with an eighth grade education made racial disparities in health care impossible to ignore. In *Under the Skin*, Villarosa lays bare the forces in the American health-care system and society that cause Black people to “live sicker and die quicker” compared to their white counterparts. Study after study of medical settings show worse treatment and outcomes for Black patients and, most powerfully, Villarosa describes the new understanding that coping with the daily scourge of racism ages Black people prematurely. Anchored by unforgettable human stories and offering incontrovertible proof, *Under the Skin* is dramatic, tragic, and necessary reading.

Linda Villarosa is a journalism professor at the City University of New York and a contributing writer at the *New York Times Magazine*, where she covers the intersection of race and health. She has also served as executive editor at *Essence* and as a science editor at *The New York Times*. Her article on maternal and infant mortality was a finalist for a National Magazine Award. She is a contributor to *The 1619 Project*.

Editor: Kris Puopolo | Agent: Alia Hanna Habib | Material: 1st pass pages

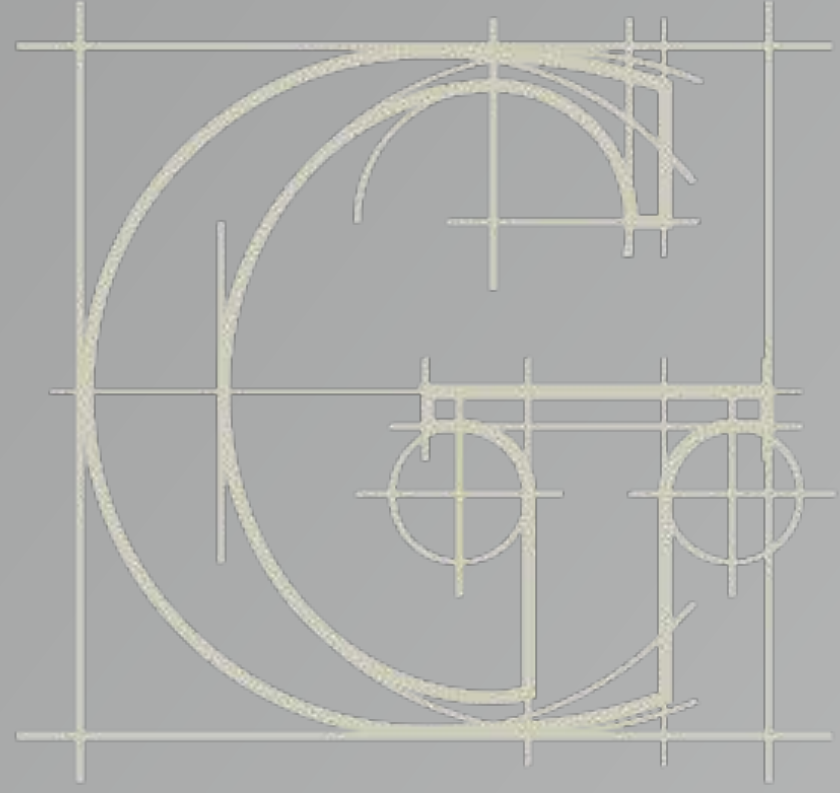

the
gernert
company

Current Releases
and
About to Publish

fiction

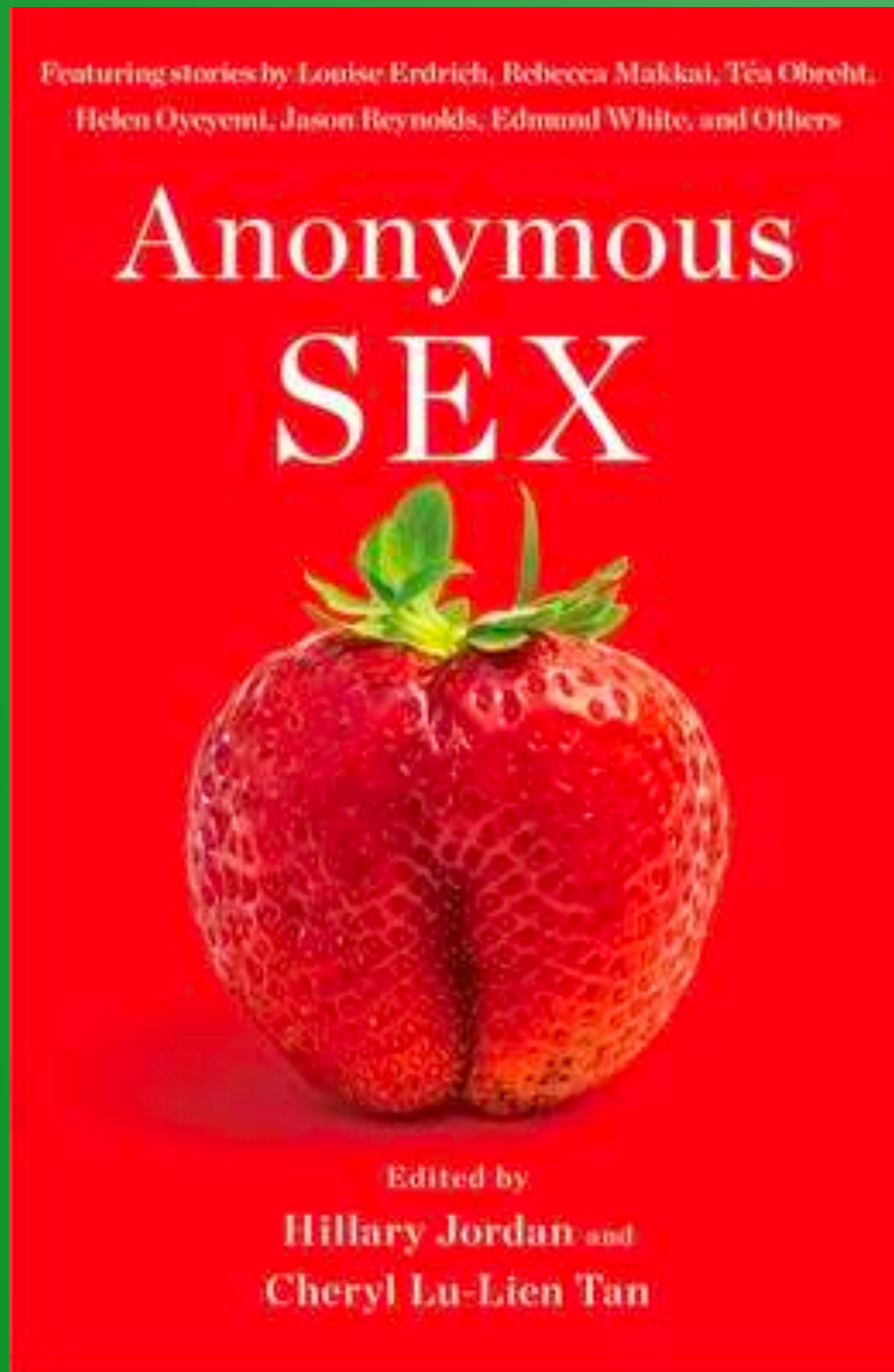

A bold collection of stories about sex that leaves you guessing who wrote what.

27 Authors. 27 Stories. No Names Attached. Original stories from Louise Erdrich, Rebecca Makkai, Téa Obreht, and more • Rave review from *NYTBR*

“The stories will satisfy you and fill you with longing... as with a casual tryst, the best part of this book is the anonymity; the promise of no strings attached.”—***New York Times Book Review***

“A sizzling assemblage of top-notch literary fiction.” —***Los Angeles Times***

“A diverse array of authors explore human sexuality . . . creates a fun mystery for the reader . . . beautifully crafted.” —***Kirkus Reviews***

anthology | *erotica* | *literary fiction*

Rights sold: UK & BC (Borough Press)

Bestselling novelists Hillary Jordan and Cheryl Lu-Lien Tan present an elegant, international anthology of erotica that explores the diverse spectrum of desire, written by winners of the Pulitzer Prize, National Book Award, PEN Awards, the Women’s Prize for Fiction, Edgar Award, and more. There are stories of sexual obsession and sexual love, of domination and submission. There’s revenge sex, unrequited sex, funny sex, tortured sex, fairy tale sex, and even sex in the afterlife. While the authors are listed in alphabetical order at the beginning of the book, none of the stories are attributed, providing readers with a glimpse into an uninhibited landscape of sexuality as explored by twenty-seven of today’s finest authors. Featuring Robert Olen Butler, Catherine Chung, Trent Dalton, Heidi W. Durrow, Tony Eprile, Louise Erdrich, Jamie Ford, Julia Glass, Peter Godwin, Hillary Jordan, Rebecca Makkai, Valerie Martin, Dina Nayeri, Chigozie Obioma, Téa Obreht, Helen Oyeyemi, Mary-Louise Parker, Victoria Redel, Jason Reynolds, S.J. Rozan, Meredith Talusan, Cheryl Lu-Lien Tan, Souvankham Thammavongsa, Jeet Thayil, Paul Theroux, Luis Alberto Urrea, and Edmund White.

Hillary Jordan is the author of the novels *Mudbound* and *When She Woke*. *Mudbound* was an international bestseller that won multiple awards and was adapted into a critically acclaimed Netflix film that earned four Academy Award nominations. She lives in Brooklyn, New York.

Cheryl Lu-Lien Tan is author of the international bestsellers *Sarong Party Girls* and *A Tiger in the Kitchen: A Memoir of Food and Family*. Born and raised in Singapore, she lives in New York City.



Margaret Atwood meets Buffy in these funny, warm, and furious stories of women at their breaking points, from Hellenic times to today.

Starred reviews from *Publishers Weekly*, *Kirkus*, and *BookPage* •
Sold in Italy and Poland

"Kirby takes joy in subverting the reader's expectations at every turn. Her characters might be naïve, even reckless, but they aren't about to be victims: They're strong, and brave, and nearly always capable of rescuing themselves."—***New York Times Book Review***

"Excellent...The prose is sharp and calibrated to suit each of Kirby's temporally and geographically diverse settings...[with] risk-taking and assured, well-developed craft. This is remarkable."—***Publishers Weekly, starred review***

"With zany plots, unconventional forms, and playful, poetic language, these stories delight at every turn."—***Kirkus Reviews, starred review***

short stories | *feminist* | *irreverent*

Rights sold: Italy (Mondadori), Poland (Proszynski Media)

Cassandra may have seen the future, but it doesn't mean she's resigned to telling the Trojans everything she knows. In this ebullient collection, virgins escape from being sacrificed, witches refuse to be burned, whores aren't ashamed, and every woman gets a chance to be a radioactive cockroach warrior who snaps back at catcallers. Gwen E. Kirby experiments with found structures--a Yelp review, a WikiHow article--which her fierce, irreverent narrators push against, showing how creativity within an enclosed space undermines and deconstructs the constraints themselves. When these women tell the stories of their triumphs as well as their pain, they emerge as funny, angry, loud, horny, lonely, strong protagonists who refuse to be secondary characters a moment longer.

Gwen E. Kirby is a native San Diegan and graduate of Carleton College. She has an MFA from Johns Hopkins University and a PhD from the University of Cincinnati. Her stories appear in *One Story*, *Tin House*, *Guernica*, *Mississippi Review*, *Ninth Letter*, *SmokeLong Quarterly*, and elsewhere. Currently, she is the associate director of programs and finance for the Sewanee Writers' Conference at the University of the South, where she also teaches creative writing.

fiction

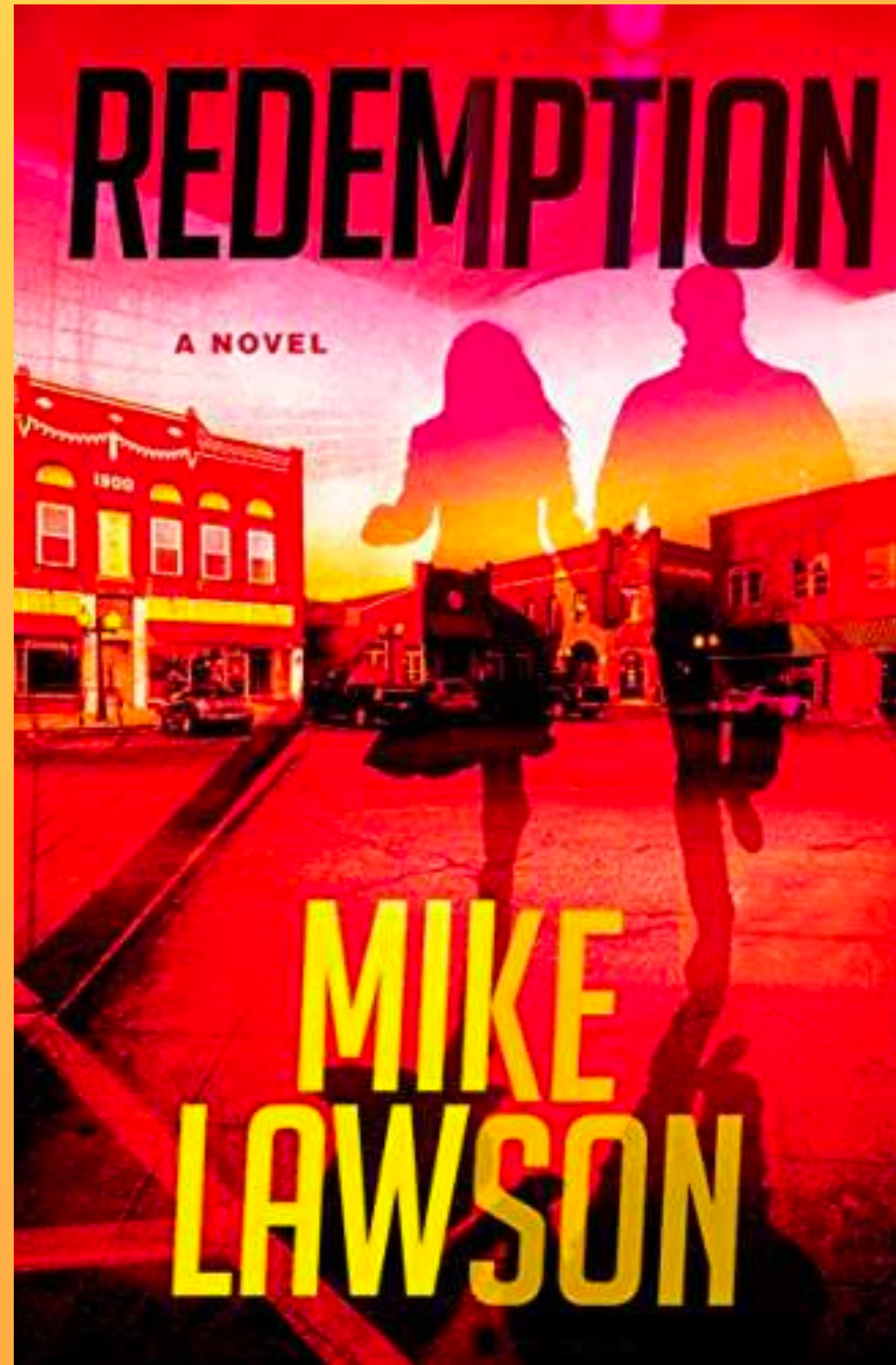

A man discovers that quitting his job comes with a price—his life—in this breakneck financial thriller from the acclaimed author of the Joe DeMarco series.

Atlantic Monthly Press - April 5, 2022

Starred PW review • Author is a Barry Award and Edgar Award finalist

“This excellent legal thriller from Lawson (the Joe DeMarco series) stars high-flying New York lawyer Jamison Maddox, who has lost his job at Goldman Sachs after participating in financial crimes.”—***Publishers Weekly, starred review***

thriller | finance | suspense

With his reputation permanently marred by an insider trading conviction, Jamison Maddox, a young Wall Street broker, reluctantly takes a job doing research for a small company in the sleepy town of Redemption, Illinois. He’s never heard of the company, or of the town, but he’s out of money and options. Though Jamison notices right away that everyone in Redemption is in some way related to one another, the big city boy chalks it up to small town ways. And as for the company’s seemingly extreme security practices, Jamison was planning on minding his own business anyway.

But when he falls in love with a beautiful and enigmatic colleague, Gillian, Jamison begins to realize that he may be doing illegal work for the company. So when she asks him to run away with her, he agrees wholeheartedly. The two set off across the country, hoping to secure some money and go into hiding. The company is soon on their tails, pursuing them with the single-minded goal of silencing them forever.

If Jamison hadn’t realized how dangerous these people really are, he now realizes they will stop at nothing to protect the company. And he has no idea that his lover, a stunning woman shrouded in mystery, is as dangerous as the people he’s running from.

Mike Lawson is a former senior civilian executive for the US Navy. He is the Edgar Award-nominated author of fifteen novels starring Joe DeMarco and three novels with his protagonist Kay Hamilton.

Editor: Peter Blackstock | Agent: David Gernert | Material: Final pages

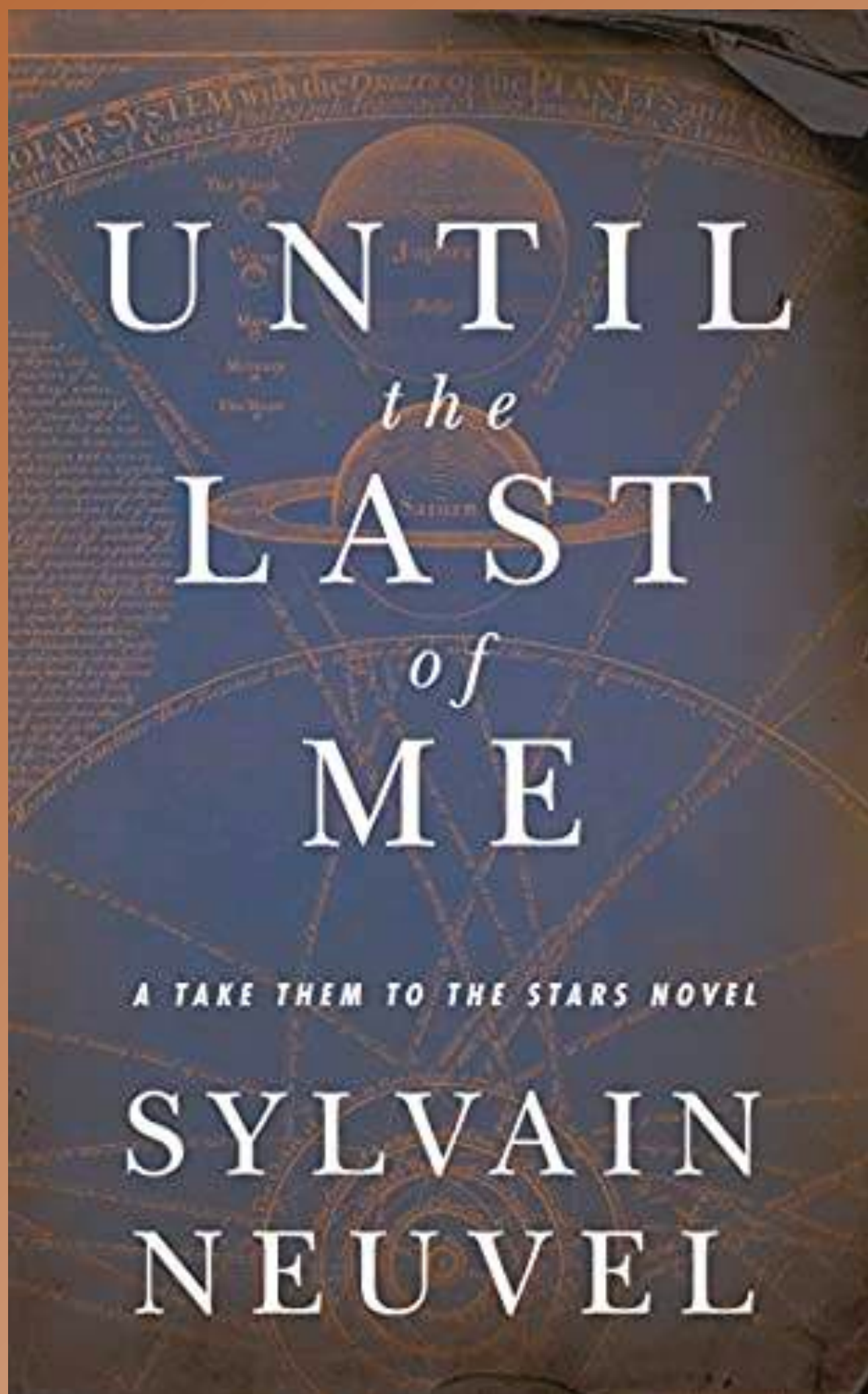

A darkly satirical thriller, as seen through the eyes of the women who sacrifice all to make progress possible and the men who are determined to stop them.

tor.com - March 29, 2022

Second book in the *Take Them to the Stars* trilogy • 3-book deals in the US and UK • Rights to *The Themis Files* series sold in 24 languages

“An exciting science fiction thriller that will in turn inform and surprise readers.”
—*Library Journal*, **starred review**

“Thrilling... the focus on Lola’s emotional state and Samael’s struggle not to become a monster add depth to the drama.” —*Publishers Weekly*

“A riveting blend of historical thriller and scientific speculation, which never loses its core of humanity” —**James Rollins**, #1 *New York Times* bestselling author, on *A History of What Comes Next*

science fiction | rocketry | space

Rights sold: UK & BC (Michael Joseph), Romania (RAO)

The First Rule is the most important: *Always run, never fight*. For generations, Mia’s family has shaped human history to push them to the stars. The year is 1968 and she is on the cusp of destiny, poised to launch the first humans into space. But she cannot take them to the stars, not quite yet. Her adversary is at her heels, the future of the planet at stake, and obeying the First Rule is no longer an option. For the first time in one-hundred generations, Mia’s family will have to choose to stand their ground, risking not only their bloodline, but the future of the human race.

Sylvain Neuvel dropped out of high school at age 15. Along the way, he has been a journalist, worked in soil decontamination, sold ice cream in California, and peddled furniture across Canada. He received a Ph.D. in linguistics from the University of Chicago. He taught linguistics in India, and worked as a software engineer in Montreal. He is also a certified translator, though he wishes he were an astronaut. He likes to tinker, dabbles in robotics and is somewhat obsessed with Halloween. He is the author of *The Themis Files* trilogy.

Editor: Lee Harris | Agent: Seth Fishman | Material: Final pages

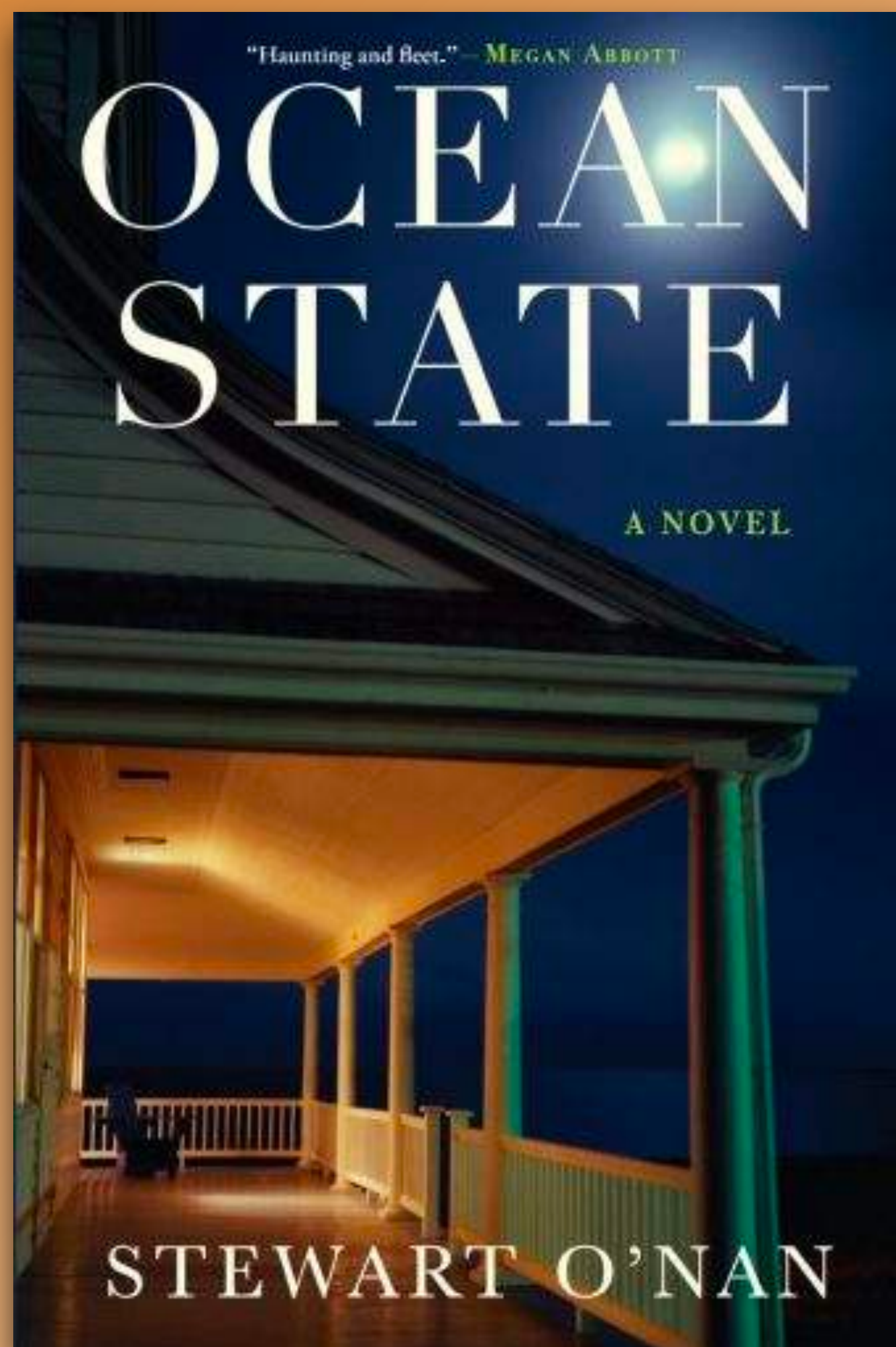

Set in a working-class town on the Rhode Island coast, O'Nan's latest is a crushing, beautifully written, and profoundly compelling novel about sisters, mothers, and daughters, and the terrible things love makes us do.

Grove Press - March 15, 2022

Starred PW and a new relationship with Grove for this work of searing fiction by the bestselling author heralded as one of America's contemporary masters

"[A] beautifully rendered and heartbreaking story... This isn't a crime novel; it's a Shakespearean tragedy told in spare, poetic, insightful prose."—**Publishers Weekly, starred review**

"Prolific, protean O'Nan examines a familiar subject, hard-pressed working-class life in America, through the lens of a Rhode Island murder... the book is rich in social detail... and warmed by O'Nan's customary tenderness for ordinary lives. *Everyday People* was the title of one of his first great novels, in 2001, and depicting everyday people with sensitive acuity remains one of his principal artistic achievements here...finely rendered with poignant realism."—**Kirkus Reviews**

"Stewart O'Nan is out to break your heart in the most beautiful way. He is writing with his full power unleashed. This book is a classic."—**Luis Alberto Urrea**

mystery | *family dynamics* | *literary fiction*

Rights sold: UK & BC (Grove), Germany (Rowohlt), France (Editions L'Olivier)

In the first line of *Ocean State*, we learn that a high school student was murdered, and we find out who did it. The story that unfolds from there with incredible momentum is thus one of the build-up to and fall-out from the murder, told through the alternating perspectives of the four women at its heart. Angel, the murderer, Carol, her mother, and Birdy, the victim, all come alive on the page as they converge in a climax both tragic and inevitable. Watching over it all is the retrospective testimony of Angel's younger sister Marie, who reflects on that doomed autumn of 2009 with all the wisdom of hindsight. O'Nan's expert hand paints a fully realized portrait of these women, but also weaves a compelling and heartbreaking story of working-class life in Ashaway, Rhode Island.

Stewart O'Nan is the author of numerous books, including *Wish You Were Here*, *Everyday People*, *In the Walled City*, *The Speed Queen*, and *Emily, Alone*. His 2007 novel, *Last Night at the Lobster*, was a national bestseller and a finalist for the *Los Angeles Times* Book Prize. He was born and raised in Pittsburgh, where he lives with his family.

Editor: Morgan Entrekin | Agent: David Gernert | Material: Final pages

fiction

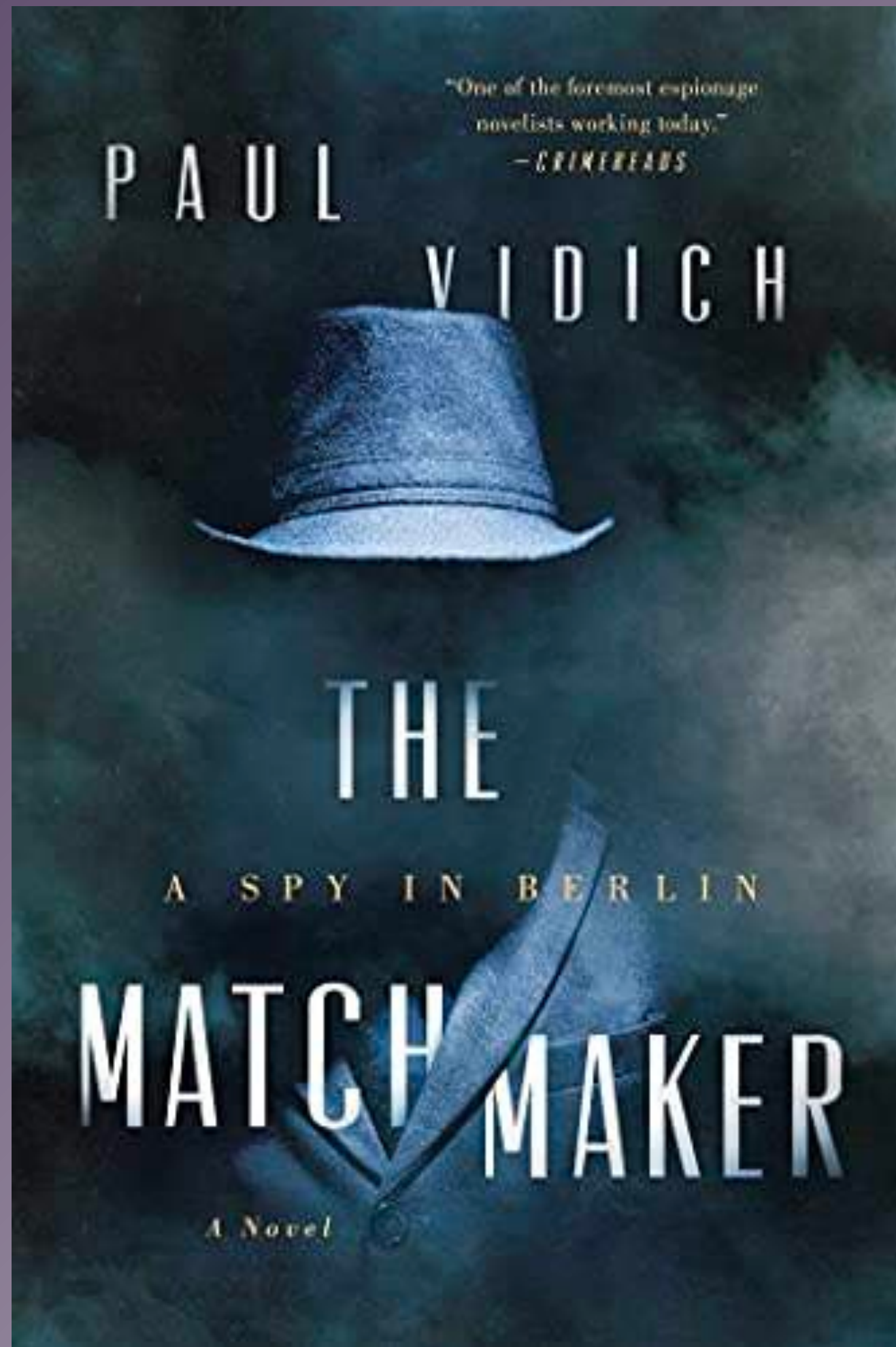

The Matchmaker delivers a chilling Cold War spy story set in West Berlin, where an American woman targeted by the Stasi must confront the truth behind her German husband's mysterious disappearance.

In the vein of Graham Greene and John le Carré a chilling Cold War spy story

- Starred Booklist and rave review in the *NYTBR*

“There is a casual elegance to Vidich’s spy fiction, a seeming effortlessness that belies his superior craftsmanship. Every plot point, character motivation and turn of phrase veers towards the understated, but they are never underwritten. *The Matchmaker* is an ideal entrance into Vidich’s work, one that should compel new readers to plumb his backlist.” —***New York Times Book Review***

“Vidich adds a welcome feminist twist to the familiar espionage theme of human lives trapped in the vice of competing and equally ruthless governments. From *An Honorable Man* (2016) through *The Mercenary* (2021), Vidich has established his position in the forefront of contemporary espionage novelists.” —***Booklist, starred review***

cold war | *thriller* | *mystery*

Rights sold: UK & BC (No Exit Press)

Berlin, 1989. Protests across East Germany threaten the Iron Curtain and Communism is the ill man of Europe. Anne Simpson, an American who works as a translator at the Joint Operations Refugee Committee, thinks she is in a normal marriage with a charming East German. But then her husband disappears, and the CIA and Western German intelligence arrive at her door. Nothing about her marriage is as it seems. She had been targeted by the Matchmaker—a high level East German counterintelligence officer—who runs a network of Stasi agents who marry vulnerable women to provide them with cover as they report back to the Matchmaker. As the only one to see her husband’s face, Anne is the CIA’s best chance to identify him before the Matchmaker escapes to Moscow. Time is running out as the Berlin Wall falls and chaos engulfs East Germany. But what if Anne's husband is not dead? And what if Anne has her own motives for finding the Matchmaker to deliver a different type of justice?

Paul Vidich is the acclaimed author of *An Honorable Man* and *The Good Assassin*, and his fiction and nonfiction have appeared in the Wall Street Journal, LitHub, CrimeReads, Fugue, The Nation, Narrative Magazine, Wordriot, and others. He lives in New York.

non-fiction

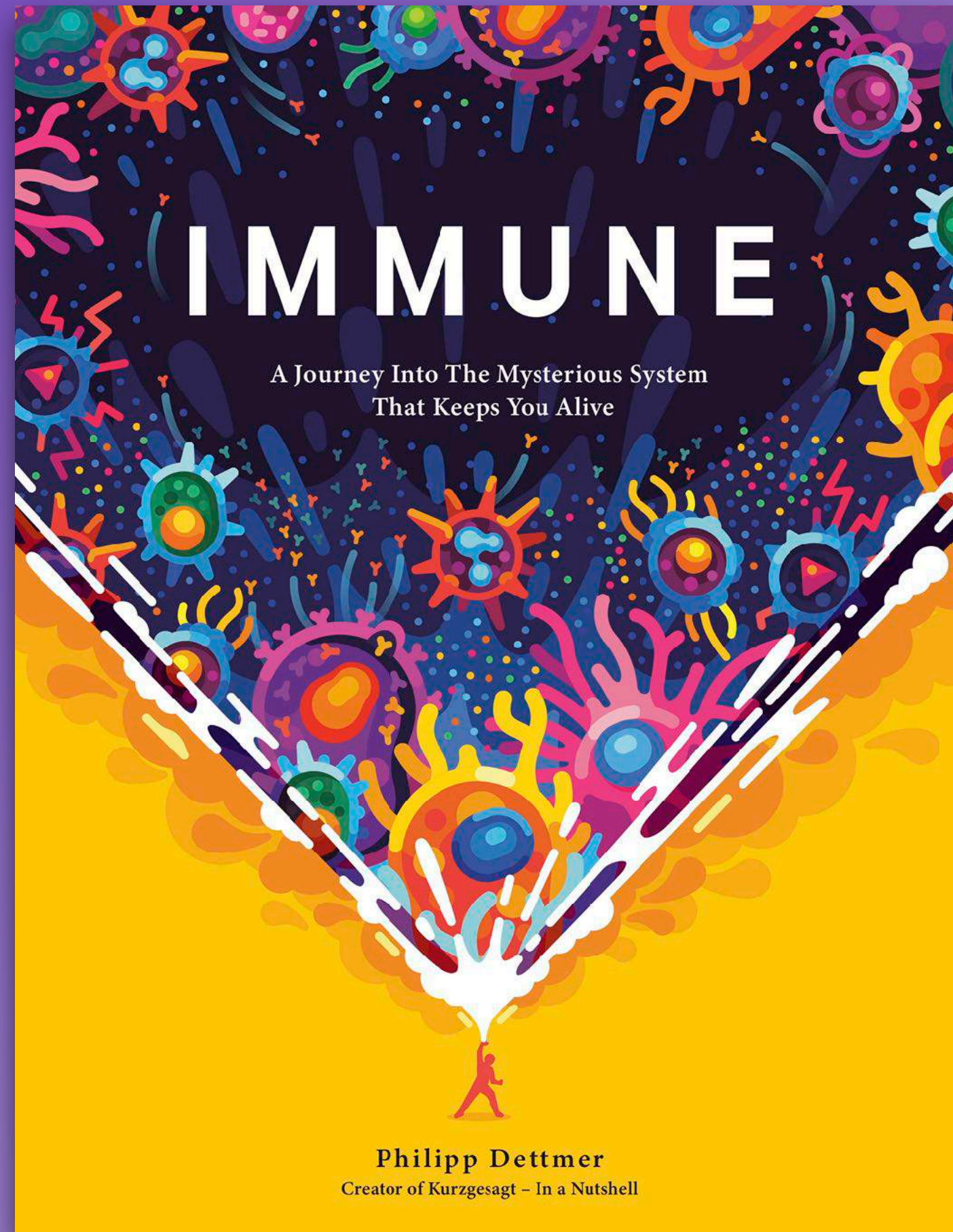

A gorgeously-illustrated deep dive into the immune system – how it works and why it is both our greatest ally and most dangerous enemy -- from the creator of the massive YouTube channel Kurzgesagt – In a Nutshell.

Random House - November 2, 2021

New York Times and international bestseller • Sold in a major deal to Random House • 28 Foreign Deals • More than 300,000 copies worldwide, with many international publications still to come

“Through wonderful analogies and a genius for clarifying complex ideas, *Immune* is a truly brilliant introduction to the human body’s vast system for fighting infections and other threats.” — **John Green**

“Bringing both insight and humor to an important and relevant topic, Dettmer’s book is essential reading, especially in light of the COVID-19 pandemic.” — **Library Journal**

popular science | *immune system* | *illustrations*

Rights sold: UK & BC (Hodder), Brazil (Senac), Bulgaria (BARD Publishing), China (Beijing Imaginist), Czech Republic (Aurora), Denmark (Svane & Bilgrave), Netherlands (Alfabet), France (Editions Tredaniel), Germany (Ullstein Verlag), Greece (Metaichmio), Hebrew (Or Am Books), Hungary (Open Books), Italy (Rizzoli), Korea (ScienceBooks / Minum), Lithuania (Kitos Knygos), Mongolia (Monsudar Publishing), Poland (Zysk), Portugal (Saida de Emergencia), Romania (Humanitas), Russia (Portal/Labirint), Slovakia (Tatran), Spain (Alienta/Planeta), Sweden (Natur & Kultur), Taiwan (Eagle Publishing), Thailand (Se-Education), Turkey (Celsius), Ukraine (Family Leisure Club), Vietnam (1980 Books).

You wake up and feel a tickle in your throat. Your head hurts. You’re mildly annoyed as you get the kids ready for school and dress for work yourself. Meanwhile, an epic war is being fought, just below your skin. Millions are fighting and dying for you to be able to complain as you head out the door. So what, exactly, is your immune system? Second only to the human brain in its complexity, it is one of the oldest and most critical facets of life on Earth. Without it, you would die within days. In *Immune*, Philipp Dettmer, the brains behind the most popular science channel on YouTube, takes readers on a journey through the fortress of the human body and its defenses. Enlivened by eye-popping graphics and immersive descriptions, *Immune* turns one of the most intricate, interconnected, and confusing subjects—immunology—into a gripping adventure through an astonishing alien landscape. *Immune* is a vital and remarkably fun crash course in what is arguably, and increasingly, the most important system in the body.

Philipp Dettmer is the founder and head writer of Kurzgesagt – “in a nutshell” - one of the largest science channels on Youtube with 16 millions subscribers and around a billion views.

Editor: Ben Greenberg | Agent: Seth Fishman | Material: Final pages

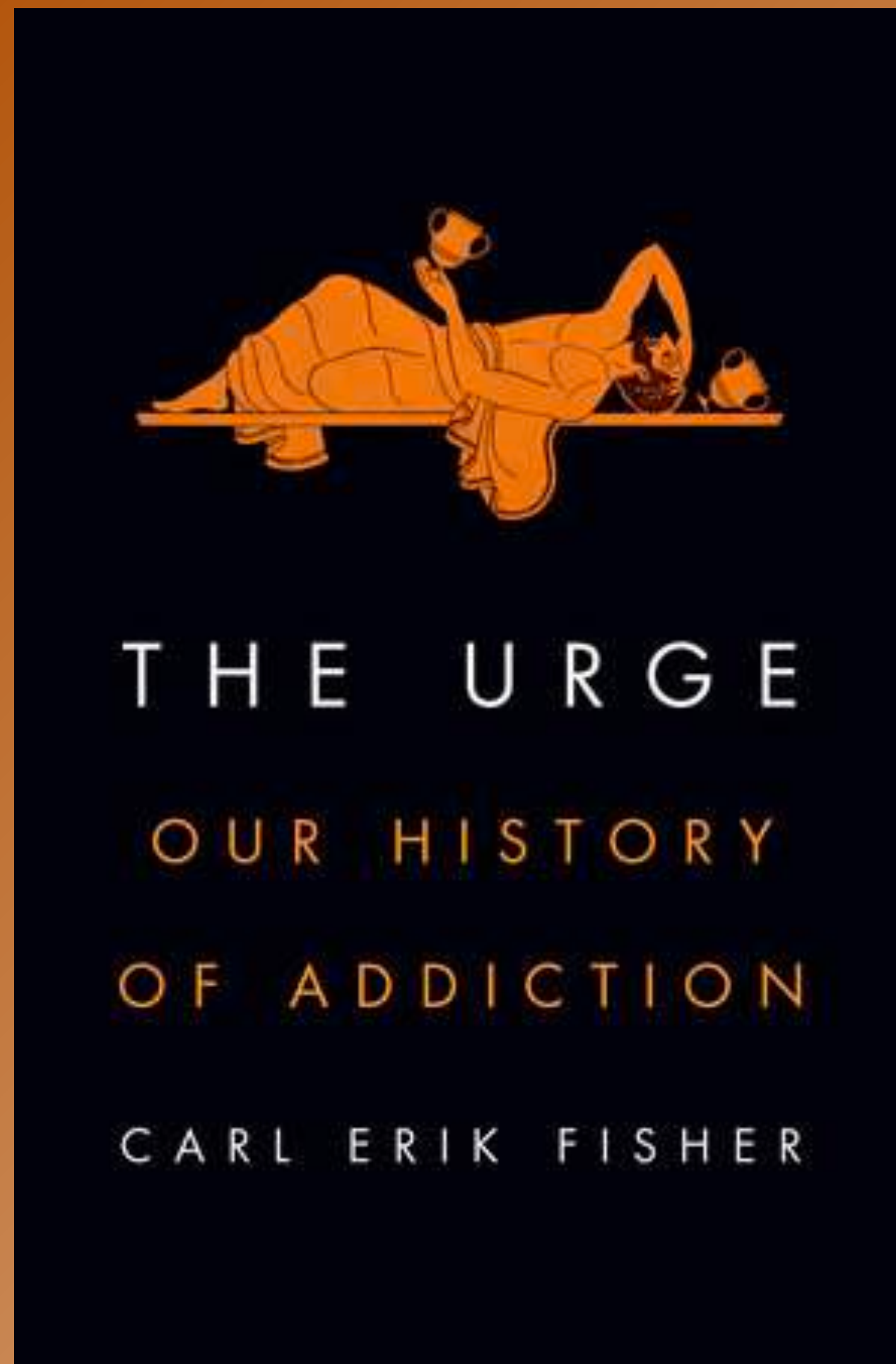

Addiction is a phenomenon that remains baffling and deeply misunderstood despite having touched countless lives. An exploration by an psychiatrist striving to understand his own family and himself

Penguin Press - January 18, 2022

An authoritative, illuminating, and deeply humane history of addiction •
Rave reviews from *The New Yorker* and *Publishers Weekly* • Sold in 5 territories

“A compelling history. . . . Fisher, an addiction physician and a recovering addict, illustrates the ‘terrifying breakdown of reason’ that accompanies the condition by drawing on patients’ anecdotes and on his own experience.” —***The New Yorker***

“Fisher, an assistant professor of clinical psychiatry at Columbia University, makes a striking debut by skillfully combining a cultural history of addiction with his own story of recovery..There’s as much history here as there is heart.” —***Publishers Weekly, starred review***

history of medicine | *addiction* | *sociology*

Rights sold: UK & BC (Scribe), The Netherlands (De Arbeiderspers), Japan (Misuzu),
Korea (Open Books), Spain (Urano)

Even after a decades-long opioid overdose crisis, intense controversy still rages over the fundamental nature of addiction and the best way to treat it. With uncommon empathy and erudition, Carl Erik Fisher draws on his own experience as a clinician, researcher, and alcoholic in recovery as he traces the history of a phenomenon that, centuries on, we hardly appear closer to understanding—let alone addressing effectively. A rich, sweeping history that probes not only medicine and science but also literature, religion, philosophy, and sociology, *The Urge* illuminates the extent to which the story of addiction has persistently reflected broader questions of what it means to be human and care for one another. Fisher introduces us to the people who have endeavored to address this complex condition through the ages: Only by reckoning with our history of addiction, he argues—our successes and our failures—can we light the way forward for those whose lives remain threatened by its hold.

Carl Erik Fisher is an addiction physician and bioethicist. He is an assistant professor of clinical psychiatry at Columbia University, where he works in the Division of Law, Ethics, and Psychiatry. He also maintains a private psychiatry practice focusing on complementary and integrative approaches to treating addiction. His writing has appeared in *Nautilus*, *Slate*, and *Scientific American MIND*, among other outlets. He lives in Brooklyn, New York, with his partner and son.

Editor: Emily Cunningham | Agent: Alia Hanna Habib | Material: Final pages

non-fiction

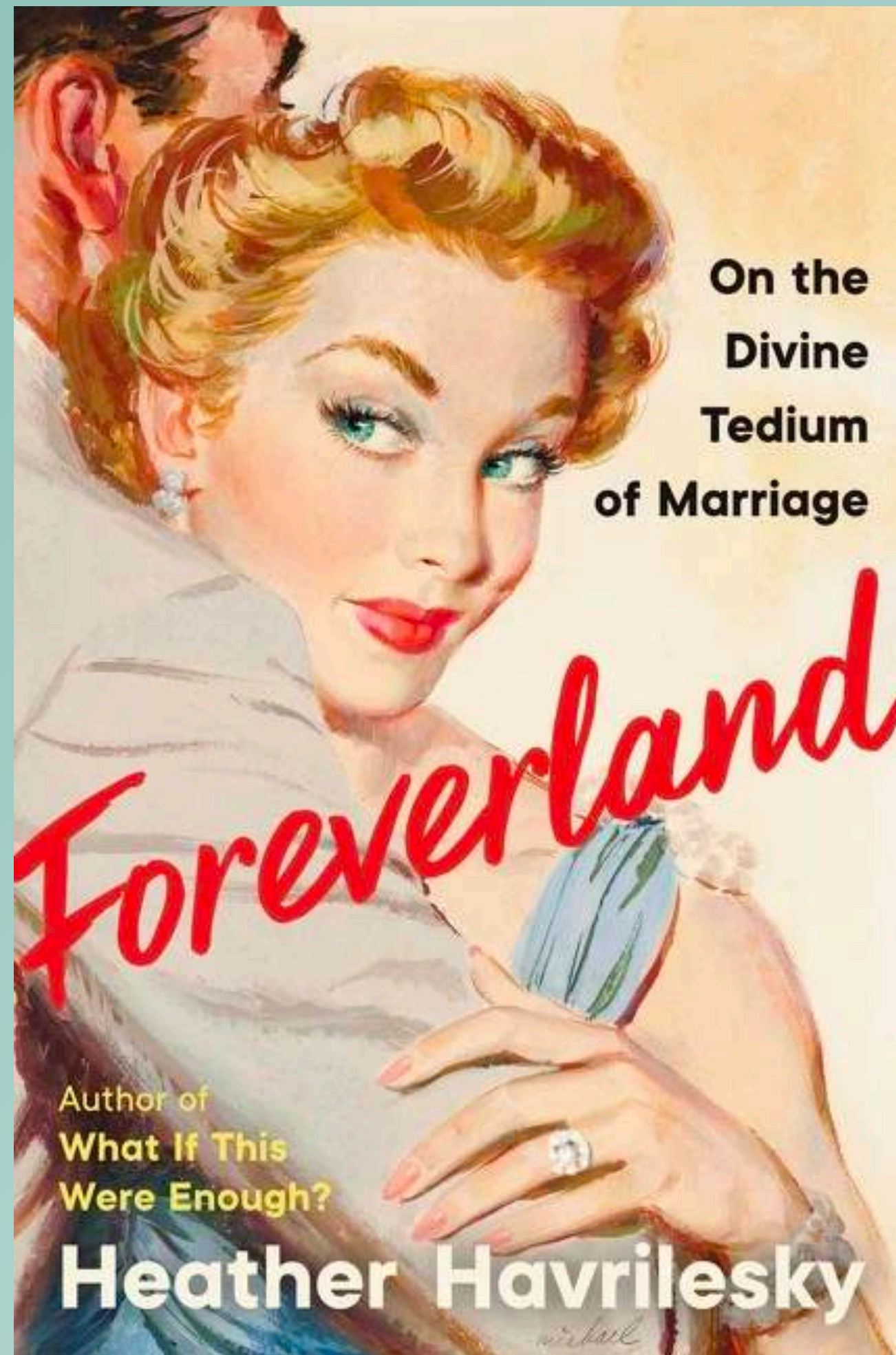

An illuminating, poignant, and savagely funny examination of modern marriage from Ask Polly advice columnist Heather Havrilesky

Ecco - February 8, 2022

World English rights sold in a six-figure deal • Previous work has been featured in *The New Yorker*, *The Atlantic*, and *The New York Times Magazine*,

Newlyweds, nearlyweds, and golden-anniversary celebrants alike will find much that is familiar, inspiring, and comforting in Havrilesky's clear-eyed paean to marital bliss and blunders."
—**Booklist, starred review**

"Both married and unmarried audiences will find something to cherish in this book on what it means to have a good marriage, what a marriage is at all, and how to retain one's identity, as well as desires, in the face of binding yourself to another."—**Literary Hub**

"Funny, forthright...Whether single or spoken for, readers are sure to fall for Havrilesky's charming memoir."—**BookPage**

marriage | advice | humor

If falling in love is the peak of human experience, then marriage is the slow descent down that mountain, on a trail built from conflict, compromise, and nagging doubts. Considering the limited economic advantages to marriage, the deluge of other mate options a swipe away, and the fact that almost half of all marriages in the United States end in divorce anyway, why do so many of us still chain ourselves to one human being for life? In *Foreverland*, Heather Havrilesky illustrates the delights, aggravations, and sublime calamities of her marriage over the span of fifteen years, charting an unpredictable course from meeting her one true love to slowly learning just how much energy is required to keep that love aflame. This refreshingly honest portrait of a marriage reveals that our relationships are not simply "happy" or "unhappy," but something much murkier—at once unsavory, taxing, and deeply satisfying. With tales of fumbled proposals, harrowing suburban migrations, external temptations, and the bewildering insults of growing older, *Foreverland* is a work of rare candor and insight. Havrilesky traces a path from daydreaming about forever for the first time to understanding what a tedious, glorious drag forever can be.

Heather Havrilesky is the author of *What if This Were Enough?*, *How to Be a Person in the World*, and *Disaster Preparedness*. She writes the "Ask Polly" column for *New York* magazine as well as the newsletter "Ask Molly," and has written for *The New Yorker*, *The Atlantic*, *The New York Times Magazine*, and NPR's *All Things Considered*, among others. She was *Salon*'s TV critic for seven years. She lives in Los Angeles with her husband and their children.

Editor: Denise Oswald | Agent: Sarah Burnes | Material: Final pages

non-fiction

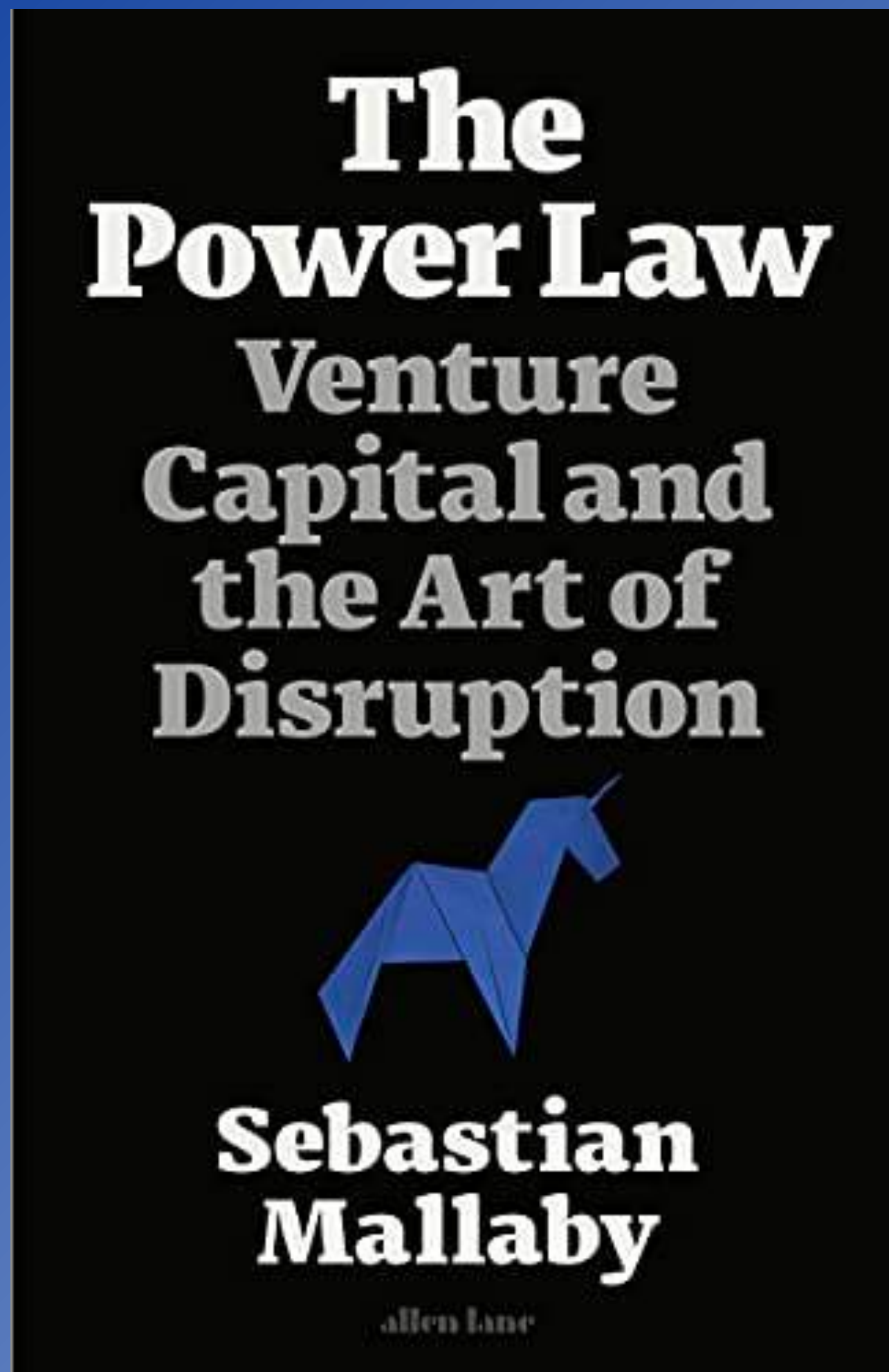

An astonishingly frank and intimate story of Silicon Valley's dominant venture-capital firms—and how their strategies and fates have shaped the path of innovation and the global economy

Penguin Press - February 1, 2022

A gripping, essential history of venture capital from a two-time Pulitzer Prize finalist • Raves from the *WSJ* and *Washington Post* • Foreign deals in 6 territories

“A gripping fly-on-the-wall story of the rise of this unique and important industry based on extensive interviews with some of the most successful venture capitalists.”

—**Daniel Rasmussen**, *Wall Street Journal*

“A must-read for anyone seeking to understand modern-day Silicon Valley and even our economy writ large.”—**Bethany McLean**, *The Washington Post*

venture capital | *technology* | *economics*

Rights sold: UK & BC (Penguin UK), China (Cheers), Brazil (Intrinseca), Korea (Wisdom House), Taiwan (Business Weekly)

Innovations rarely come from “experts.” Elon Musk was not an “electric car person” before he started Tesla. When it comes to improbable innovations, a legendary tech VC told Sebastian Mallaby, the future cannot be *predicted*, it can only be *discovered*. It is the nature of the venture-capital game that most attempts at discovery fail, but a very few succeed at such a scale that they more than make up for everything else. That extreme ratio of success and failure is the power law that drives the venture capital business, all of Silicon Valley, the wider tech sector, and, by extension, the world. Sebastian Mallaby has parlayed unprecedented access to the most celebrated venture capitalists of all time—the key figures at Sequoia, Kleiner Perkins, Accel, Benchmark, and Andreessen Horowitz, as well as Chinese partnerships such as Qiming and Capital Today—into a riveting blend of storytelling and analysis that unfurls the history of tech incubation, in the Valley and ultimately worldwide. We learn the unvarnished truth, often for the first time, about some of the most iconic triumphs and infamous disasters in Valley history, from the comedy of errors of the birth of Apple to the avalanche of venture money that fostered hubris at WeWork and Uber.

Sebastian Mallaby is the author of several books, including the bestselling *More Money Than God*. A former *Financial Times* contributing editor and two-time Pulitzer Prize finalist, Mallaby is the Paul A. Volcker Senior Fellow for International Economics at the Council on Foreign Relations.

Editor: Scott Moyers | Agent: Chris Parris-Lamb | Material: Final pages

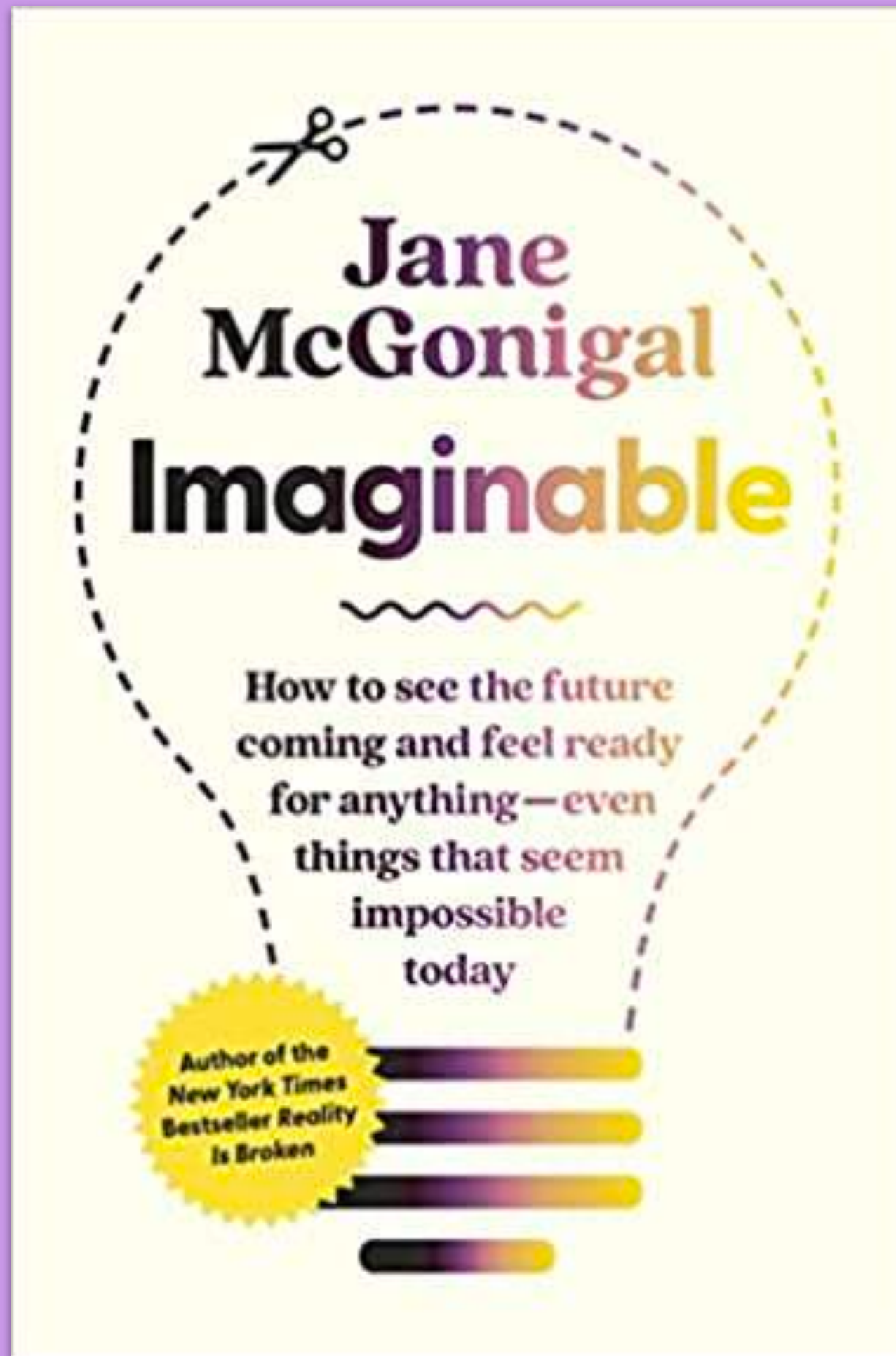

A world-renowned future forecaster and game designer teaches us to envision the future before it arrives—and gives us the tools to help shape the world we want to live in.

Spiegel & Grau - March 22, 2022

Sold in a six-figure preempt for NA • *New York Times* bestselling writer and designer of alternate reality games, Jane McGonigal’s works have been published in 14 languages • Based on a class over 50,000 people have taken on Coursera.org

“A fascinating book about how the future does not have to be an undiscovered country... A wealth of interesting ideas combined with practical guidance for new thinking.” —**Kirkus Reviews**

“Futurist and game designer McGonigal delivers an illuminating look at how imagining the future can help to change one’s own life while making a difference in the world. Expertly blending practical advice and big-picture thinking, this is a stimulating guide to preparing for the future. Readers will be inspired to put their imaginations to use.” —**Publishers Weekly**

post-pandemic reality | *self-help* | *inspirational*

Rights sold: UK & BC (Transworld), Germany (DVA Verlag), China (Cheers), Korea (Random House Korea), Italy (ROI Edizioni)

The COVID-19 pandemic, one of the most disruptive events in human history, has made it more challenging than ever to feel prepared, hopeful, and equipped to face the future with optimism. How do we map out our lives when it feels impossible to predict what the world will be like next week, let alone next year or next decade? What we need now are strategies to help us recover our confidence and creativity in facing uncertain futures. In *Imaginable*, Jane McGonigal draws on the latest scientific research in psychology and neuroscience to show us how to train our minds to think the unthinkable and imagine the unimaginable. *Imaginable* teaches us to be fearless, resilient, and bold in realizing a world with possibilities we cannot yet imagine—until reading this transformative, inspiring, and necessary book.

Jane McGonigal, PhD, is a senior researcher at the Institute for the Future and the author of *The New York Times* bestseller *Reality Is Broken: Why Games Make Us Better and How They Can Change the World*. Her work has been featured in *The Economist*, *Wired*, and *The New York Times* and on MTV, CNN, and NPR. Her TED talks on games have been viewed more than ten million times.

A tongue-in-cheek guide to the science of being a super villain by
a New York Times bestselling author

How to Take Over the World



Ryan North
New York Times bestselling author

A tongue-in-cheek introduction to the science of comic-book supervillainy, revealing the true potential of today's most advanced technologies.

“Comic book fans will fall hard for this delightfully daffy guidebook. . . . Exuberant, optimistic, and just plain fun, *How to Take Over the World* will both surprise and delight.” —**Esquire**

“An eclectic journey, full to the brim with North’s trademark sarcasm and humor. An excellent starting point for anyone interested in learning more about cutting edge science or becoming a supervillain.” —**Booklist**

supervillains | popular science | humor

Rights sold: China (CITIC), Japan (Hayakawa), Russia (EKSMO)

Taking over the world is a lot of work. Any supervillain is bound to have questions: What’s the perfect location for a floating secret base? What zany heist will fund my immoral plans? How do I control the weather, destroy the internet, and never, ever die? In *How to Take Over the World*, bestselling author and award-winning comics writer Ryan North details a number of outlandish villainous schemes, drawing on known science and real-world technologies. Picking up where *How to Invent Everything* left off, his explanations are as fun and informative as they are completely absurd. As he instructs readers on how to take over the world, North also reveals how we can save it. This sly guide to some of the greatest challenges and existential threats facing humanity accessibly explores ways to mitigate climate change, improve human life spans, prevent cyberterrorism, and finally make Jurassic Park a reality.

Ryan North is a *New York Times*–bestselling author whose books include *How to Invent Everything*, *Romeo and/or Juliet*, and *To Be or Not To Be*. He’s the creator of *Dinosaur Comics* and the Eisner Award–winning writer of *Adventure Time*, *Jughead*, and *The Unbeatable Squirrel Girl* for Marvel Comics, and he has a master’s in computational linguistics from the University of Toronto. Ryan lives in Toronto with his wife, Jenn, and their dog, Noam Chompsky.

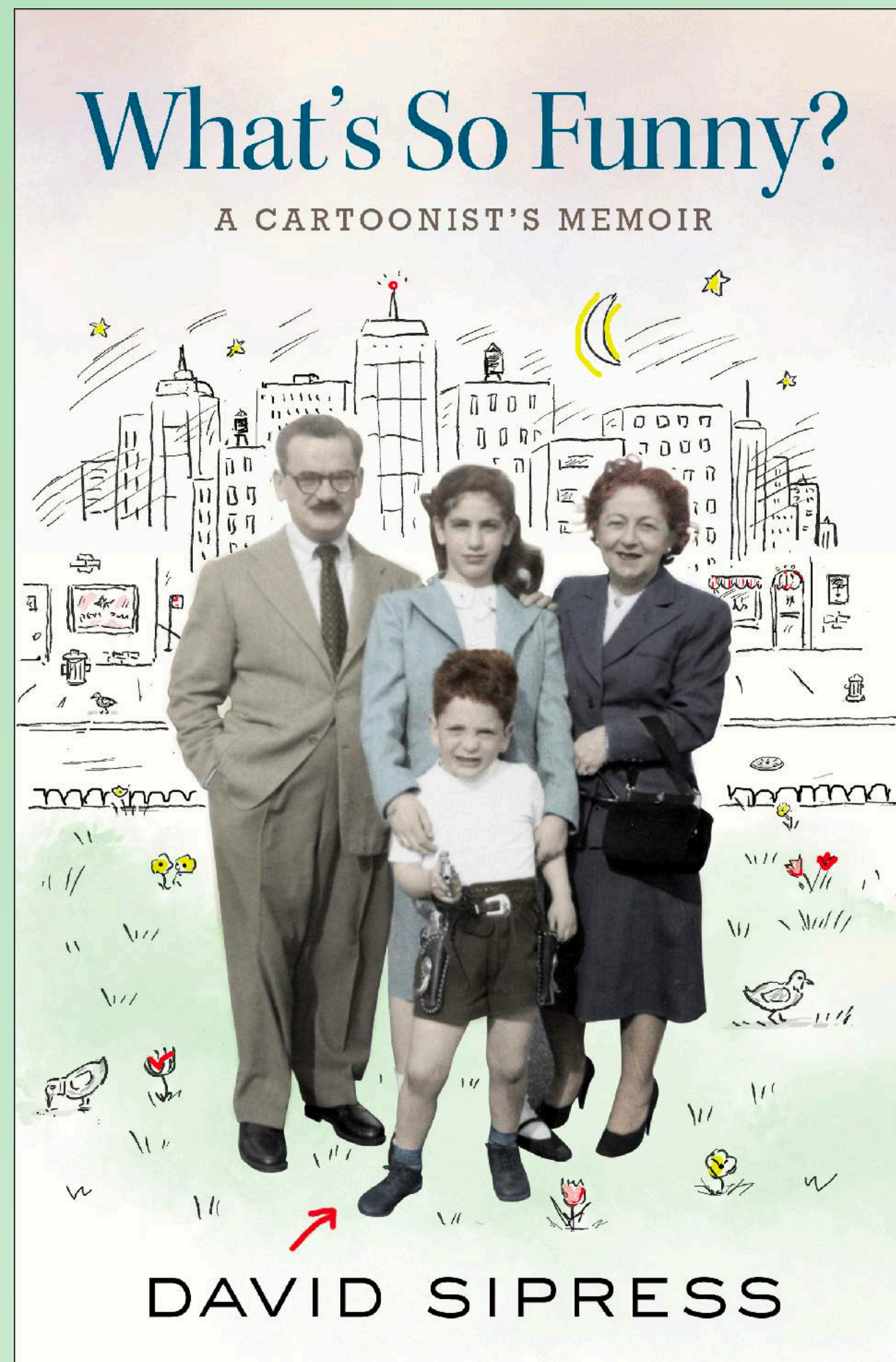

A delightful exploration about the origins of creativity.

Mariner Books - March 8, 2022

From a longtime *New Yorker* staff cartoonist, an evocative family memoir, interleaved with the author's beloved cartoons

"David Sipress, one of the most brilliant cartoonists in the history of *The New Yorker*, has written a beautiful memoir, equally moving and hilarious. It's like spending time with the funniest and kindest person you've ever met."—**Andy Borowitz, *New York Times* bestselling author and creator of *The New Yorker* satirical news column, *The Borowitz Report***

"An affectionate, introspective memoir...in crisp, clean, anecdotal prose, [Sipress] chronicles his life story, his mischievous cartooning, and the germination of his ideas. This addictive, witty, David Sedaris-esque story is a hoot." —**Kirkus, starred review**

"David Sipress's engaging, illuminating, and hilarious memoir will perhaps clarify what dark forces are at work when it comes to becoming a cartoonist rather than a podiatrist, a billionaire tech mogul, or someone who is deeply into collecting owl figurines. And if it doesn't, you will love it anyway."—**Roz Chast, author of *Can't We Talk About Something More Pleasant?***

memoir | cartoons | witty

Sipress, a dreamer and obsessive drawer living with his Upper West Side family in the age of JFK and Sputnik, goes hazy when it comes to the ceaselessly imparted lessons-on-life from his meticulous father and the angsty expectations of his migraine-prone mother. With wry and brilliantly observed prose, Sipress paints his hapless place in the family, from the time he is tricked by his unreliable older sister into rocketing his pet turtle out his twelfth-floor bedroom window, to the moment he walks away from a Harvard PhD program in Russian history to begin his life as a professional cartoonist. Sipress's cartoons appear in the story with spot-on precision, including delightful Aha moments in answer to the perennial question aimed at cartoonists: Where do you get your ideas?

David Sipress has been staff cartoonist since 1998 for *The New Yorker*, where he has published nearly 700 cartoons. He lectures widely on cartooning, and his autobiographical writing has appeared frequently on newyorker.com.

Editor: Deanne Urmy | Agent: Sarah Burnes | Material: Final pages

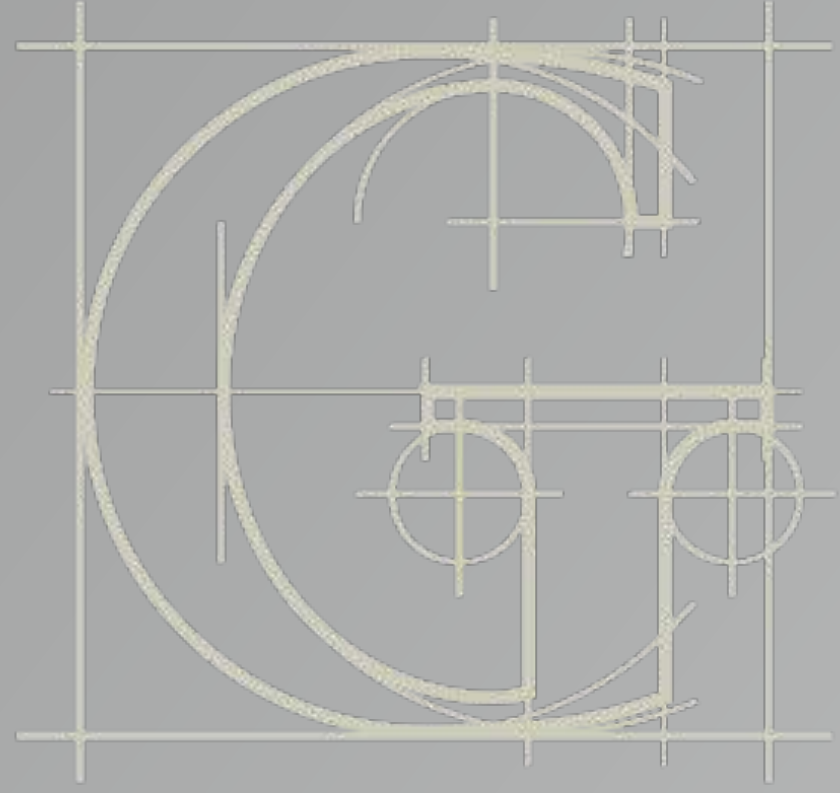

the
gernert
company

More
Opportunities

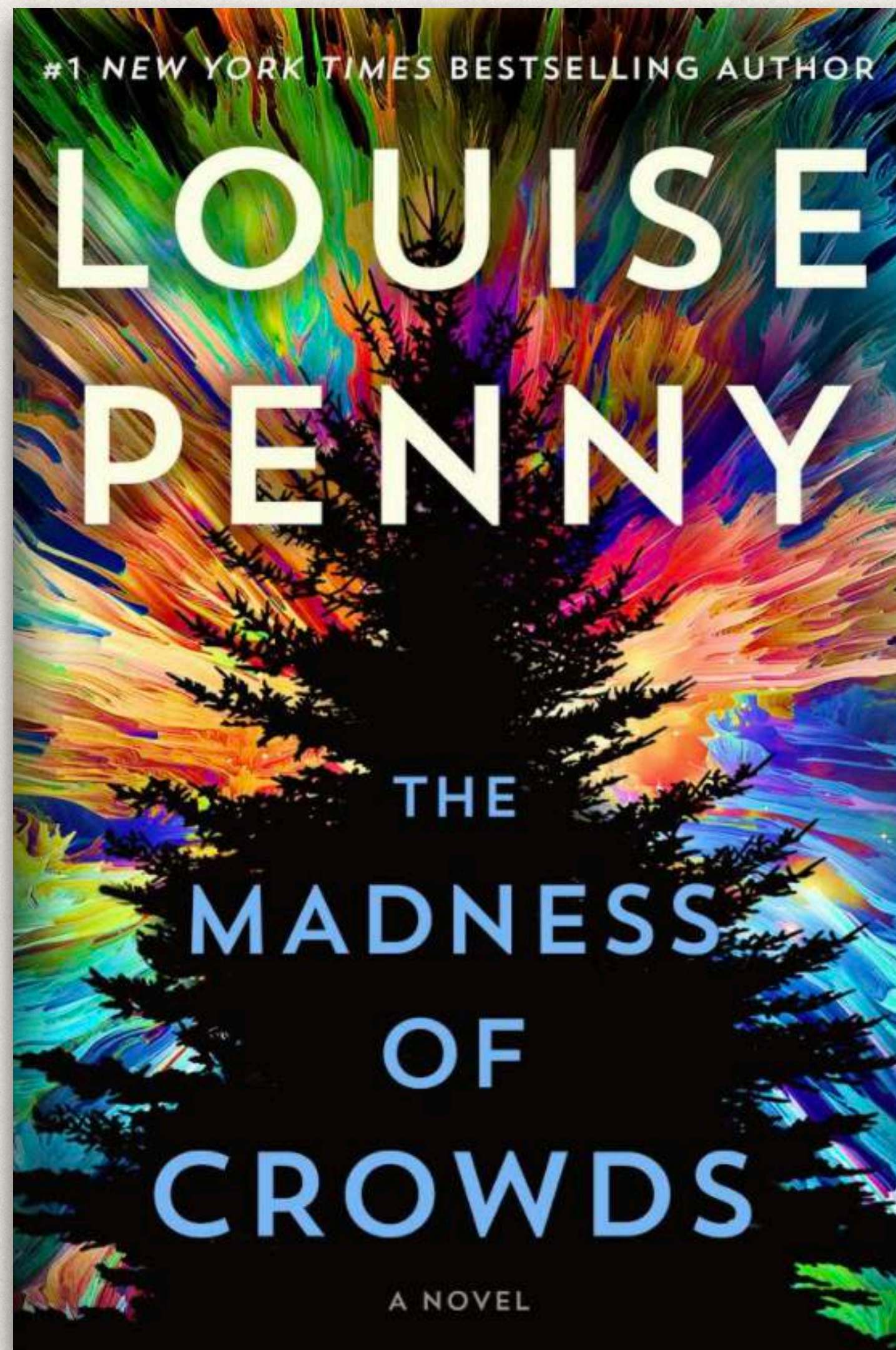

An eight times #1 New York Times bestseller, this book is the latest in Louise Penny's award-winning and beloved Inspector Gamache series.

Minotaur - August 24, 2021

The 17th Chief Inspector Gamache novel from
#1 New York Times bestselling and award-winning author Louise Penny

"This series has always excelled... This new novel grapples successfully with the moral weight of its narrative... 'All Will Be Well' never sounded so menacing."—***The New York Times Book Review***

"Provocative... brilliant... Seamlessly integrating debates about scientific experimentation and morality into a fair-play puzzle, Penny excels at placing her characters in challenging ethical quandaries. This author just goes from strength to strength."—***Publishers Weekly, starred***

"It's easily one of the best mystery novels (or novels of any genre) in recent memory."—***BookPage, starred***

"The best mysteries and thrillers rise to the level of social novels, presenting readers opportunities to confront the difficult issues we face. Penny's novels have always been driven by this (as well as the love of family and friends). *The Madness of Crowds* may be one of Penny's darkest works, but we can still find comfort in the natural beauty of Three Pines and the quirky residents we would love to have as our neighbors."—***Washington Post***

Published in 1841, Charles MacKay's book : *Extraordinary Popular Delusions and the Madness of Crowds* explored tulipmania, haunted houses, witch hunts and other events that, when looked back upon, seem deranged, unmoored from reality, yet tens of thousands believed in them. In Louise Penny's new novel written over the course of the past pandemic year, she draws on that work with Armand Gamache and others discussing it even as they themselves are swept up in events that might be delusions. The novel is an examination of crowd mentality, of crazes and follies, of what happens when greed, desperation, and delusion meet.

Louise Penny is the author of the #1 *New York Times* and *Globe and Mail* bestselling series of Chief Inspector Armand Gamache novels. She has won numerous awards, including a CWA Dagger and the Agatha Award (seven times), and was a finalist for the Edgar Award for Best Novel. In 2017, she Received the Order of Canada for her contributions to Canadian culture. Louise lives in a small village south of Montréal.

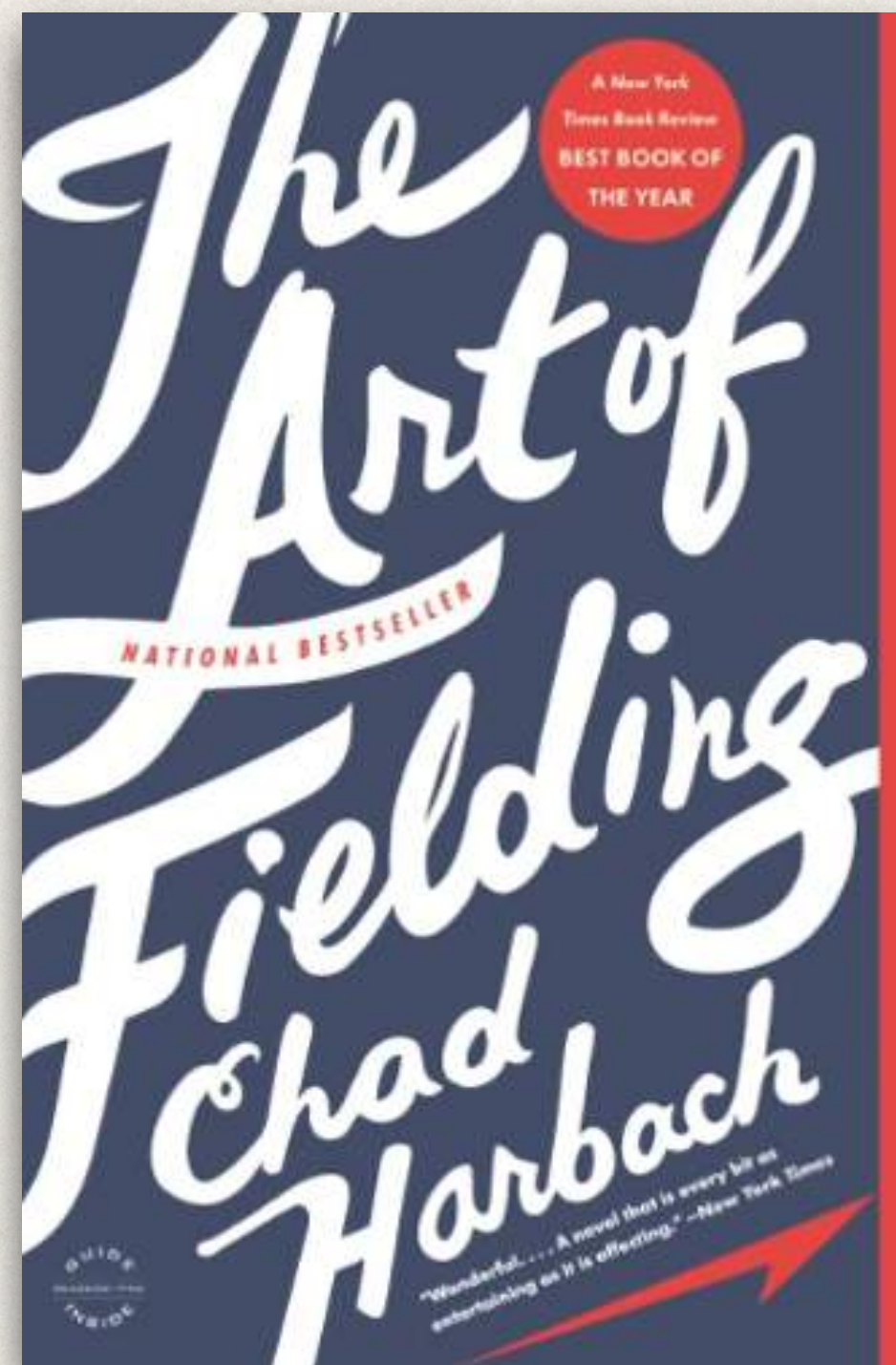

Little, Brown - September 7, 2011
Agent: Chris Parris-Lamb

Star shortstop Henry Skrimshander seems destined for the big leagues, but when a routine throw goes disastrously off course, the fates of five people are upended.

INTERNATIONAL BESTSELLER
More than 600,000 copies sold • Amazon's #1 Pick of 2011 • Chosen for 30 "Best Of" lists • TV rights under development with Sundance TV and Todd Field (*In the Bedroom*) producing • 20 foreign deals

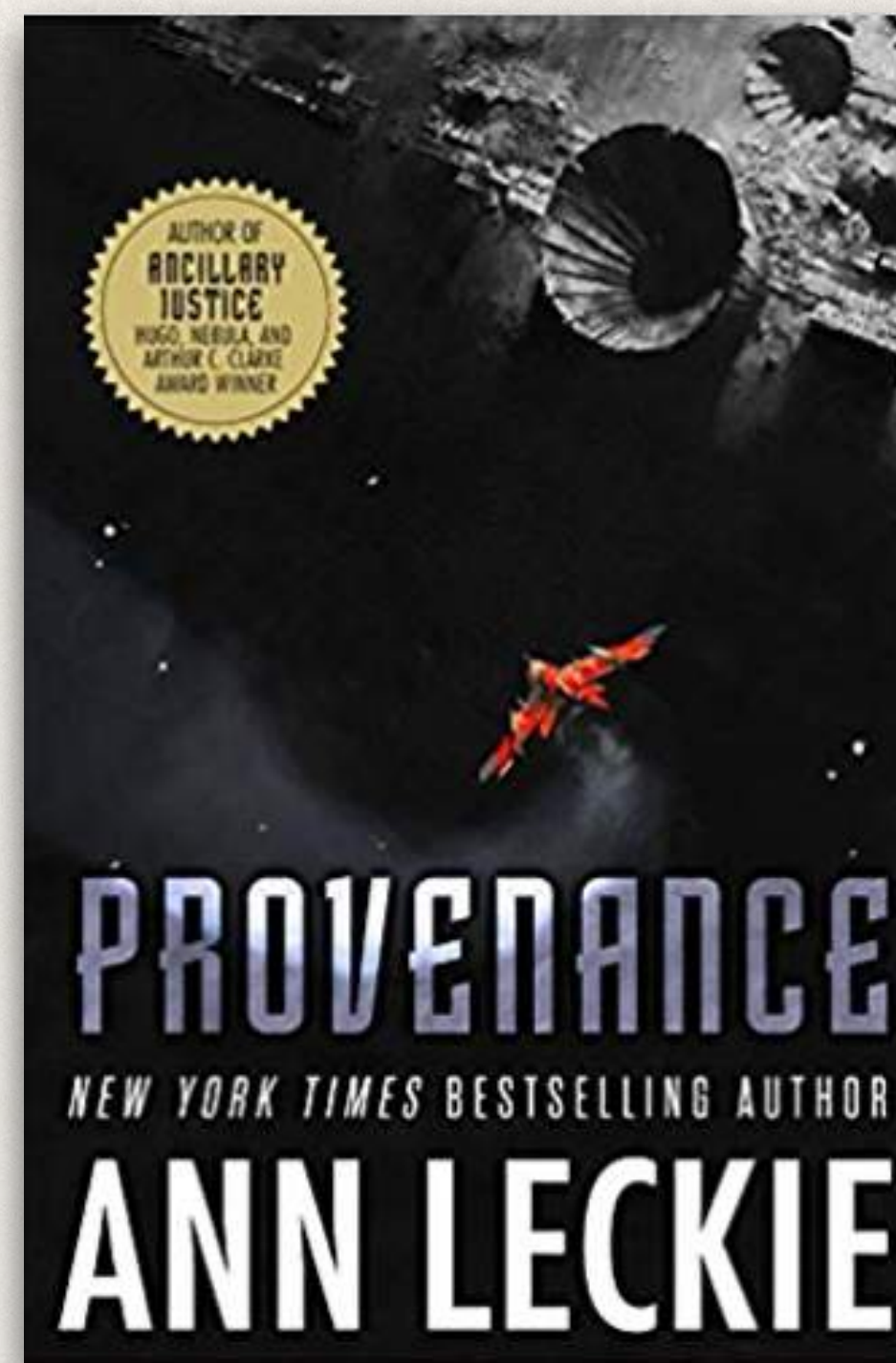

Orbit - September 26, 2017
Agent: Seth Fishman

An ambitious young woman has just one chance to secure her future and reclaim her family's priceless lost artifacts in this stand-alone novel set in the world of the Imperial Radch trilogy.

Part of the NYT bestselling Imperial Radch trilogy universe • Hugo Award for Best Novel 2018 nominee • Locus Award for Best Science Fiction Novel 2018 nominee • Leckie translated into 24 languages

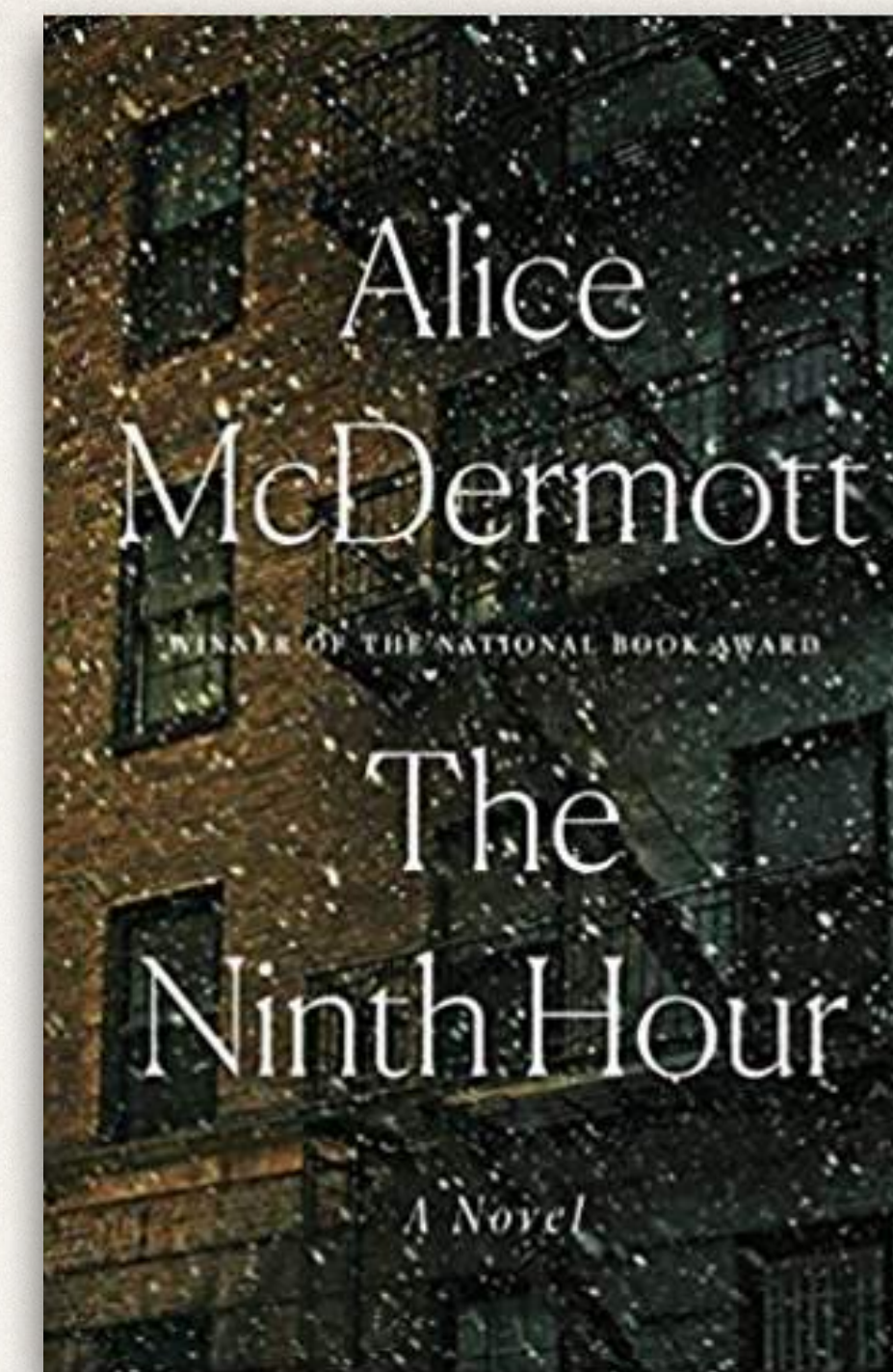

FSG - September 19, 2017
Agent: Sarah Burnes

A powerfully affecting story spanning the twentieth century of a widow and her daughter and the nuns who serve their Irish-American community in Brooklyn.

National Book Critics Circle Award in Fiction finalist • NYT Book Review's 100 Notable Books of 2017 • Kirkus Reviews' Best Fiction of 2017 • Library Journal's Top 10 Novels of 2017 • WSJ's Top Novels of 2017

fiction

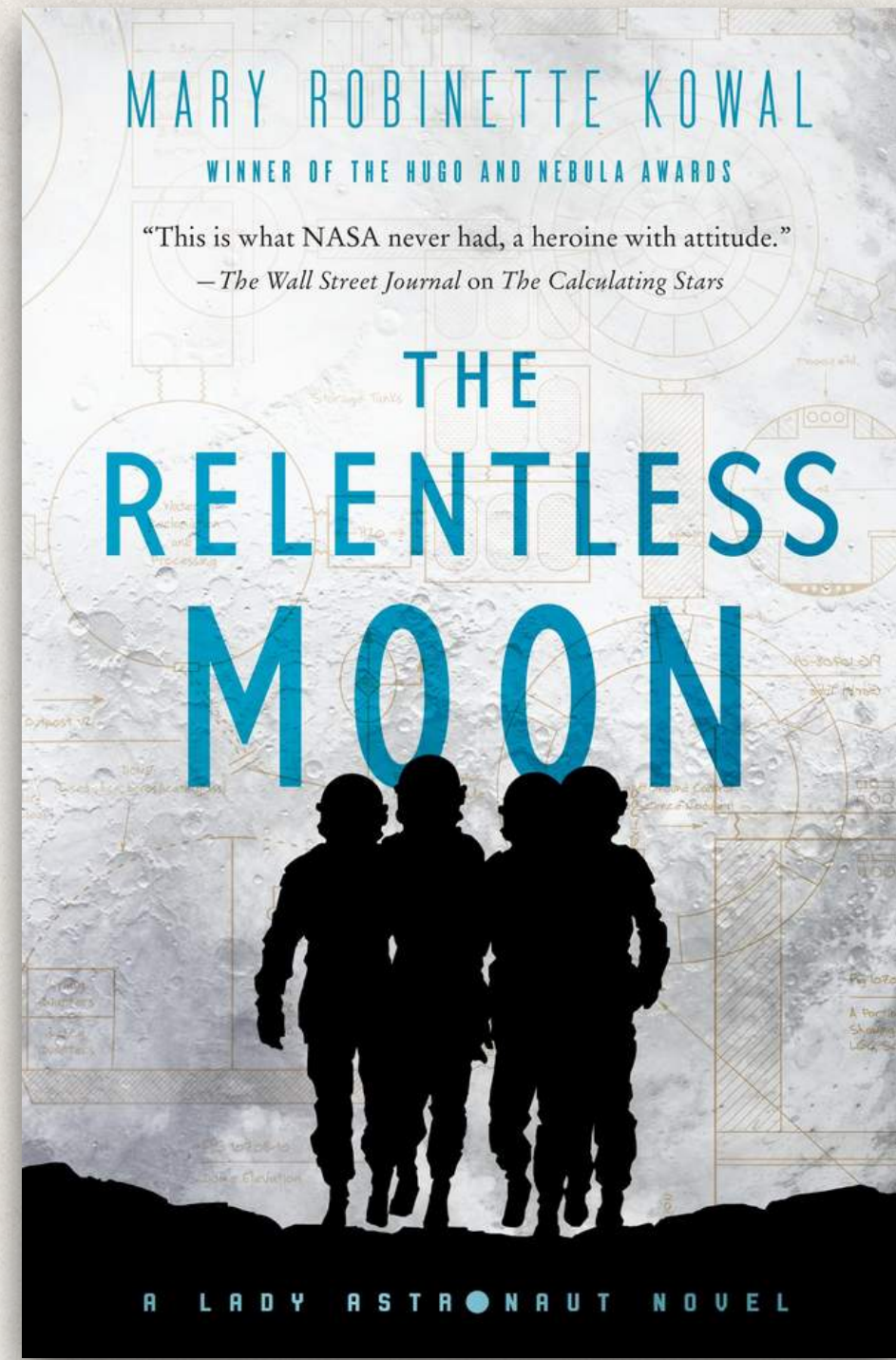

Tor Books - July 14, 2020
Agent: Seth Fishman

The third novel in the acclaimed Lady Astronaut series which has won the Hugo, Nebula and Locus Awards.

“This is what NASA never had, a heroine with attitude.”—*The Wall Street Journal* • “The Lady Astronaut series might be set in an alternate past, but they’re cutting edge SF novels that speak volumes about the present.”—*The Verge*

fiction

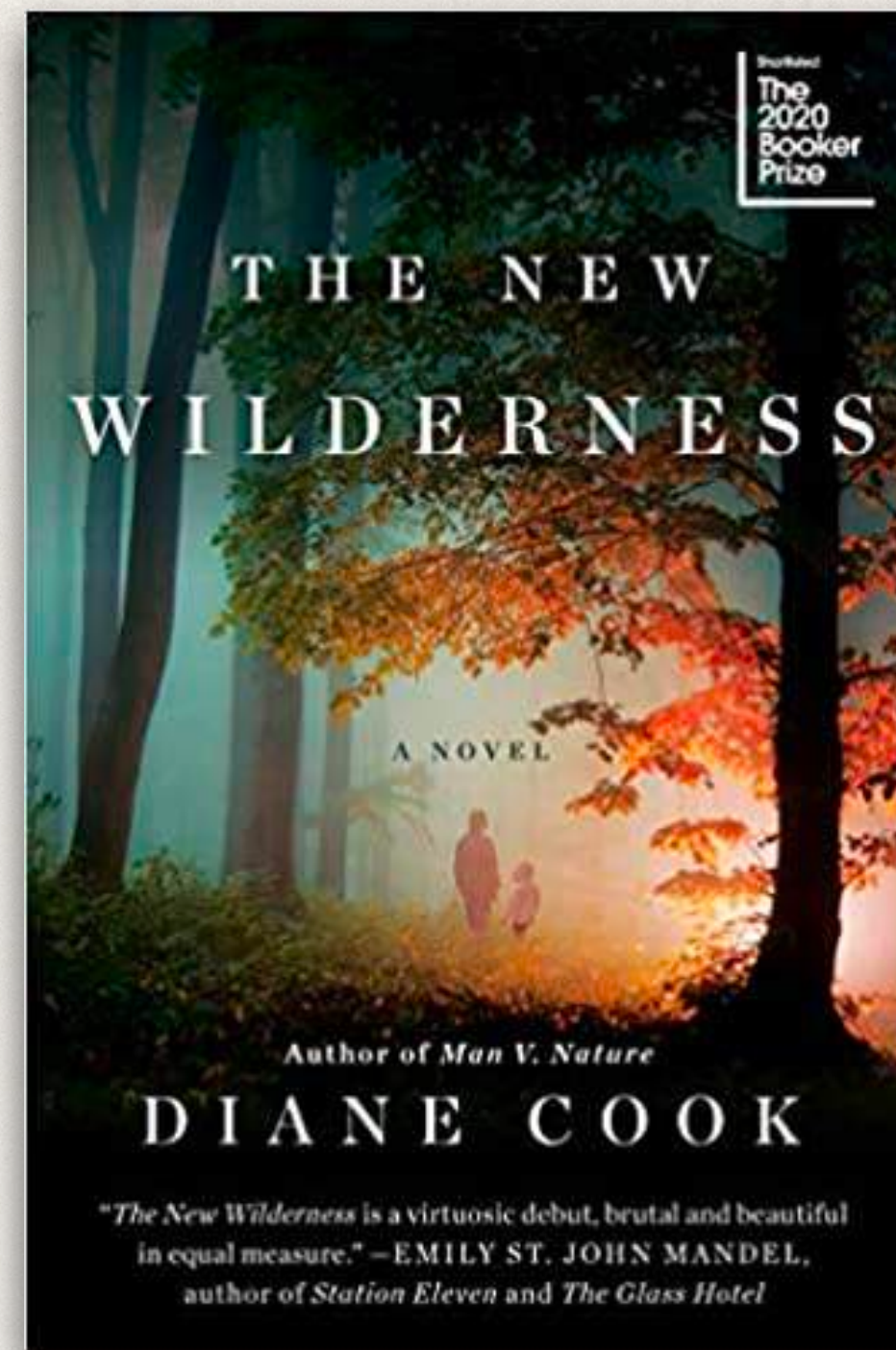

Harper - August 11, 2020
Agent: Seth Fishman

Helen Phillips meets Miranda July in this daring and imaginative debut novel that explores a moving mother-daughter relationship in a world ravaged by climate change and overpopulation.

Shortlisted for the Booker Prize 2020
• TV rights sold to Warner Bros. at auction • Starred reviews in *Kirkus*, *Publishers Weekly*, and *Booklist* • Fifteen foreign deals!

fiction

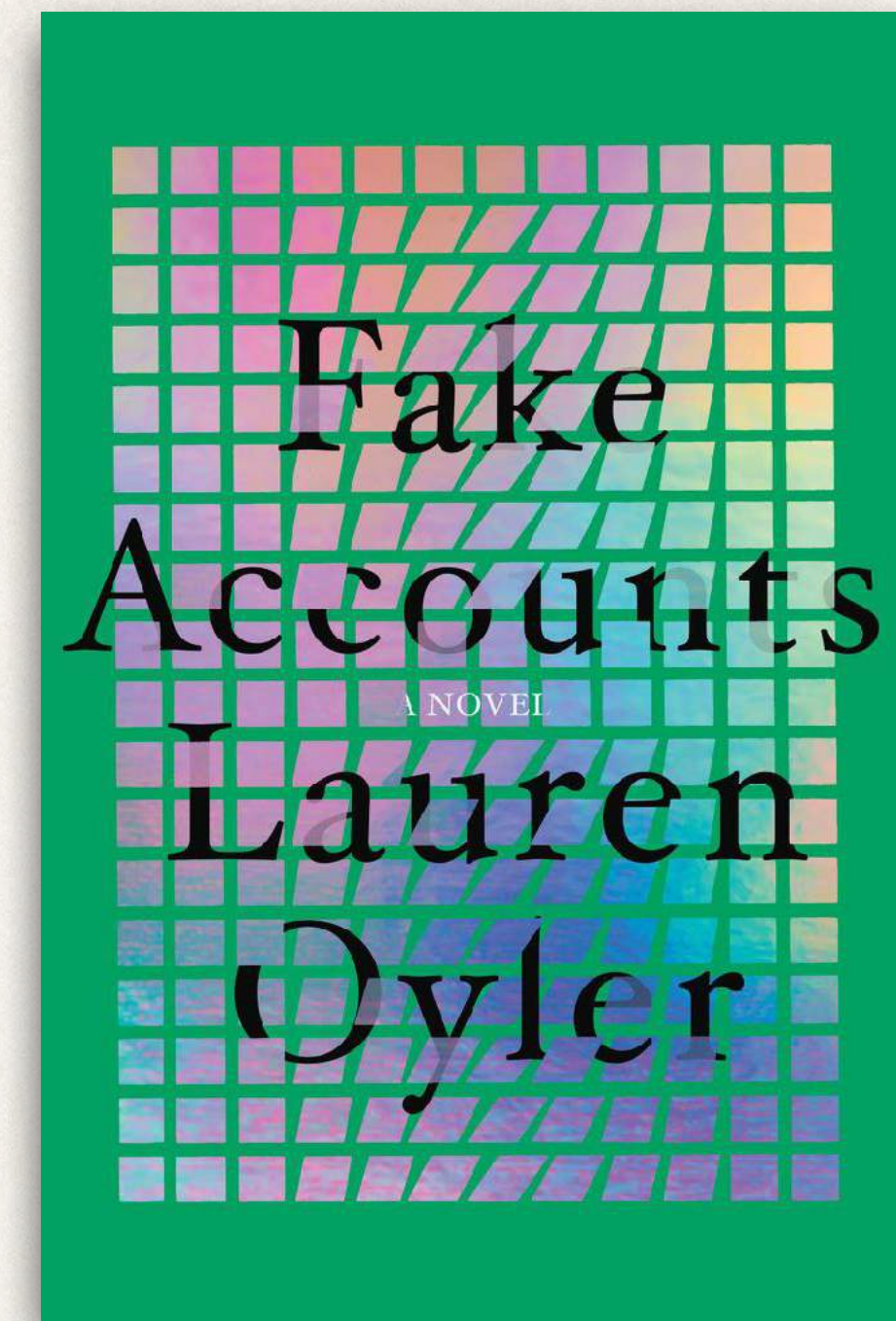

Catapult - February 2, 2021
Agent: Alia Hanna Habib

This provocative and subversive debut novel examines social media, sex, feminism, and fiction, the connection they've all promised, and the lies they help us tell

A National Bestseller • Starred *Booklist* and *PW* • Rave reviews from NYTBR, LitHub, TIME, Guardian, Bookforum • A *New York Times Book Review* Editor's Choice

fiction

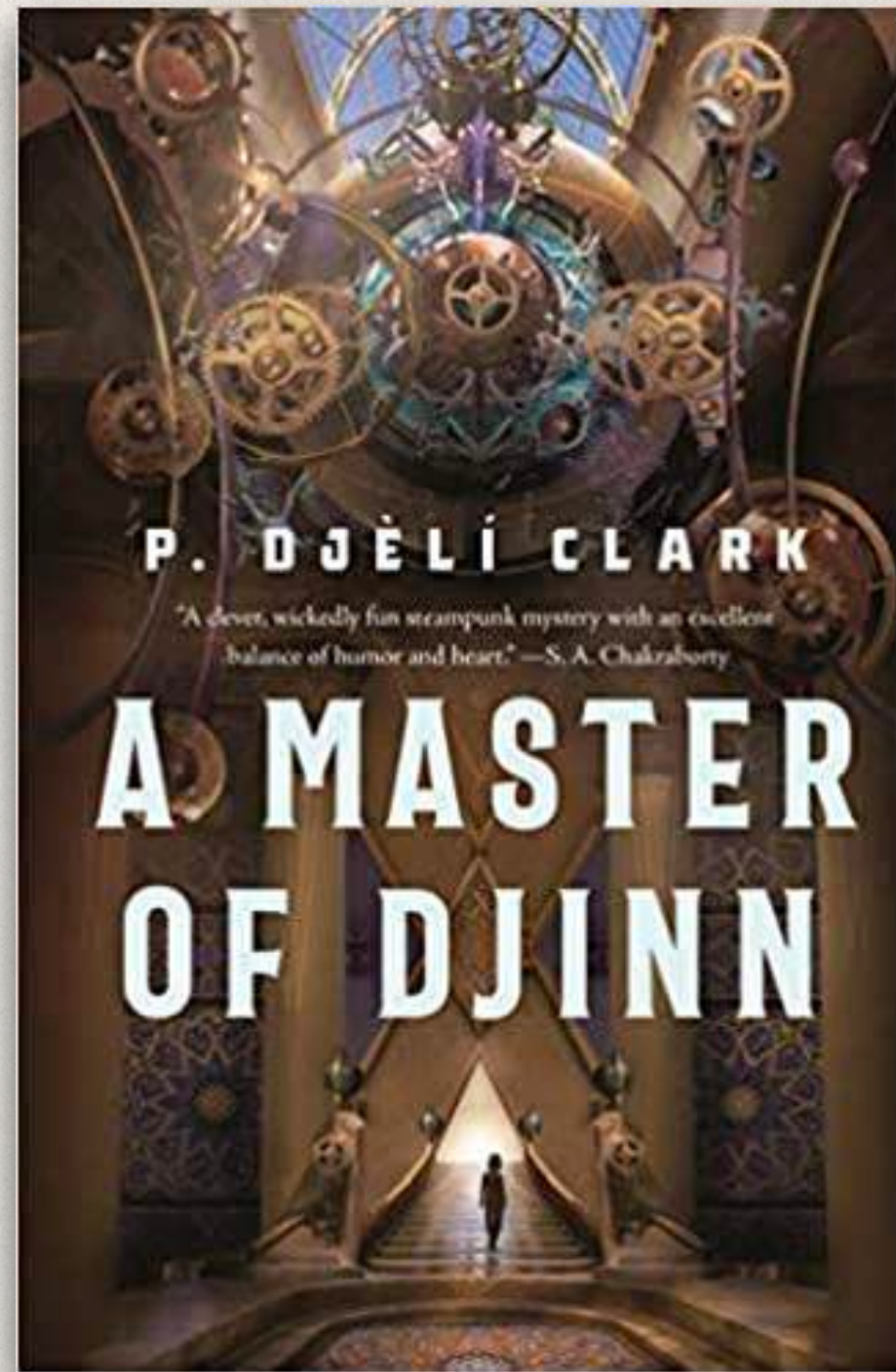

Tor.com - May 11, 2021
Agent: Seth Fishman

Nebula, Locus, and Alex Award-winner P. Djèlí Clark returns to his popular alternate Cairo universe for his fantasy novel debut, *A Master of Djinn*

7 foreign deals • Clark is the winner of the Nebula, Locus and Alex awards • Blurbs from S. A. Chakraborty, Mary Robinette Kowal and Rebecca Roanhorse, among many others

fiction

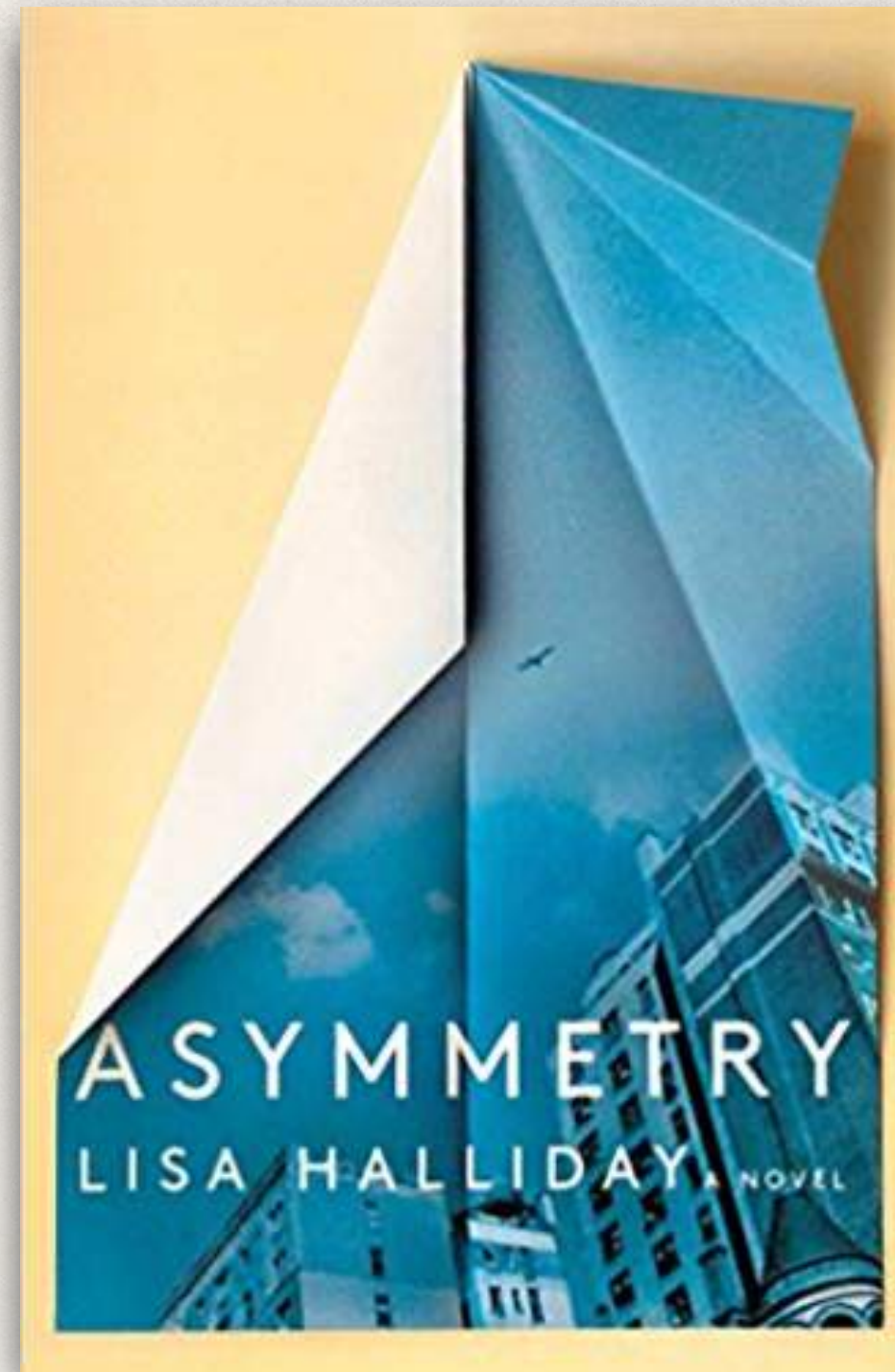

Simon & Schuster - February 6, 2018
Agent: Chris Parris-Lamb

A singularly inventive and unforgettable debut novel about love, luck, and the inextricability of life and art.

2017 Whiting Award winner • Starred reviews in Publishers Weekly, Kirkus, Booklist • One of Vulture's "100 Best Books of the 21st Century" • Major NYT author profile • 19 foreign deals

fiction

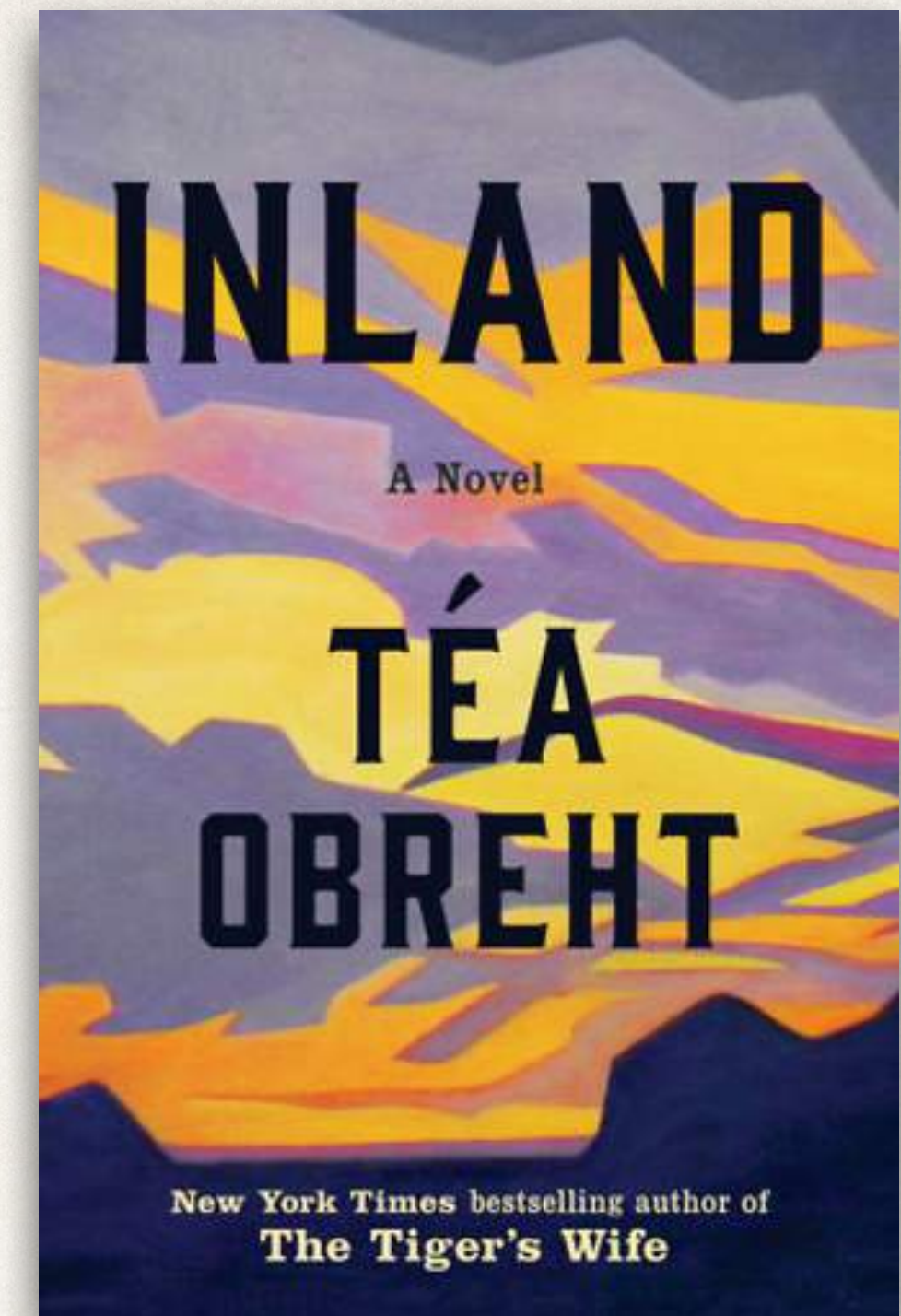

Random House - August 13, 2019
Agent: Seth Fishman

The NYT bestselling and Orange Prize-winning author of *The Tiger's Wife* returns with a stunning tale of perseverance that follows an epic journey across an unforgettable landscape of magic and myth.

Finalist for the Dylan Thomas Prize • Top 10 bestseller in the US and UK • Chosen by Barack Obama for his 2019 summer reading list • 11 foreign deals

fiction

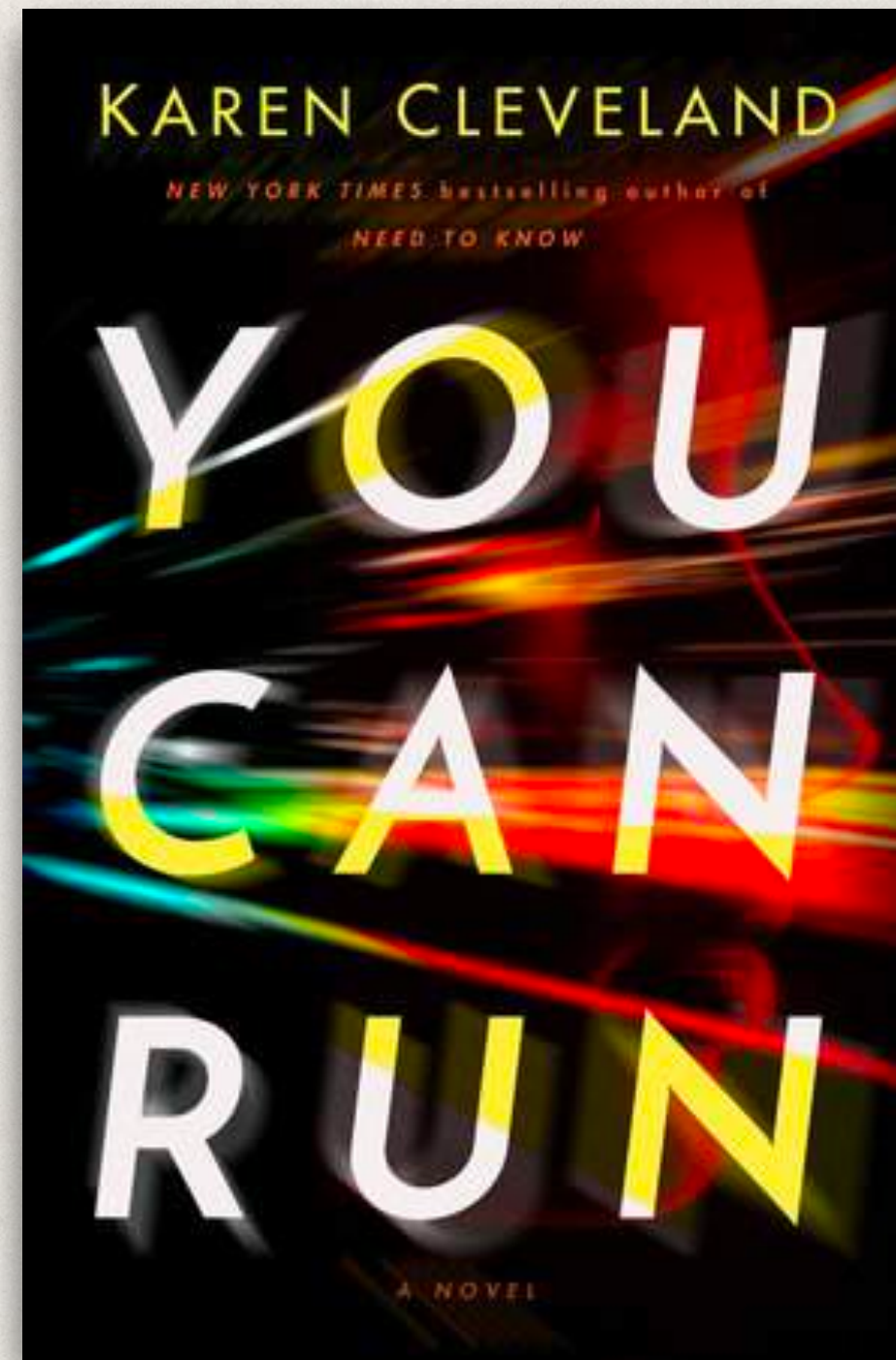

Ballantine - August 31, 2021
Agent: David Gernert

A CIA analyst makes a split-second decision that endangers her country but saves her son—and now she must team up with a journalist she’s not sure she can trust in this electrifying thriller from the *New York Times* bestselling author.

NA rights sold in a six-figure, two-book deal to Ballantine • *New York Times* bestselling author of NEED TO KNOW that was licensed in thirty-one territories

fiction



Mariner/HMH - February 23, 2021
Agent: Chris Parris-Lamb

A chilling and suspenseful novel about a young girl rescued from an orphanage by an otherworldly grandmother, by the acclaimed author of *The White King*.

10 foreign deals • Finalist for Le prix du Meilleur livre étranger (France) • First serial in the Winter 2020 issue of *The Paris Review*

fiction

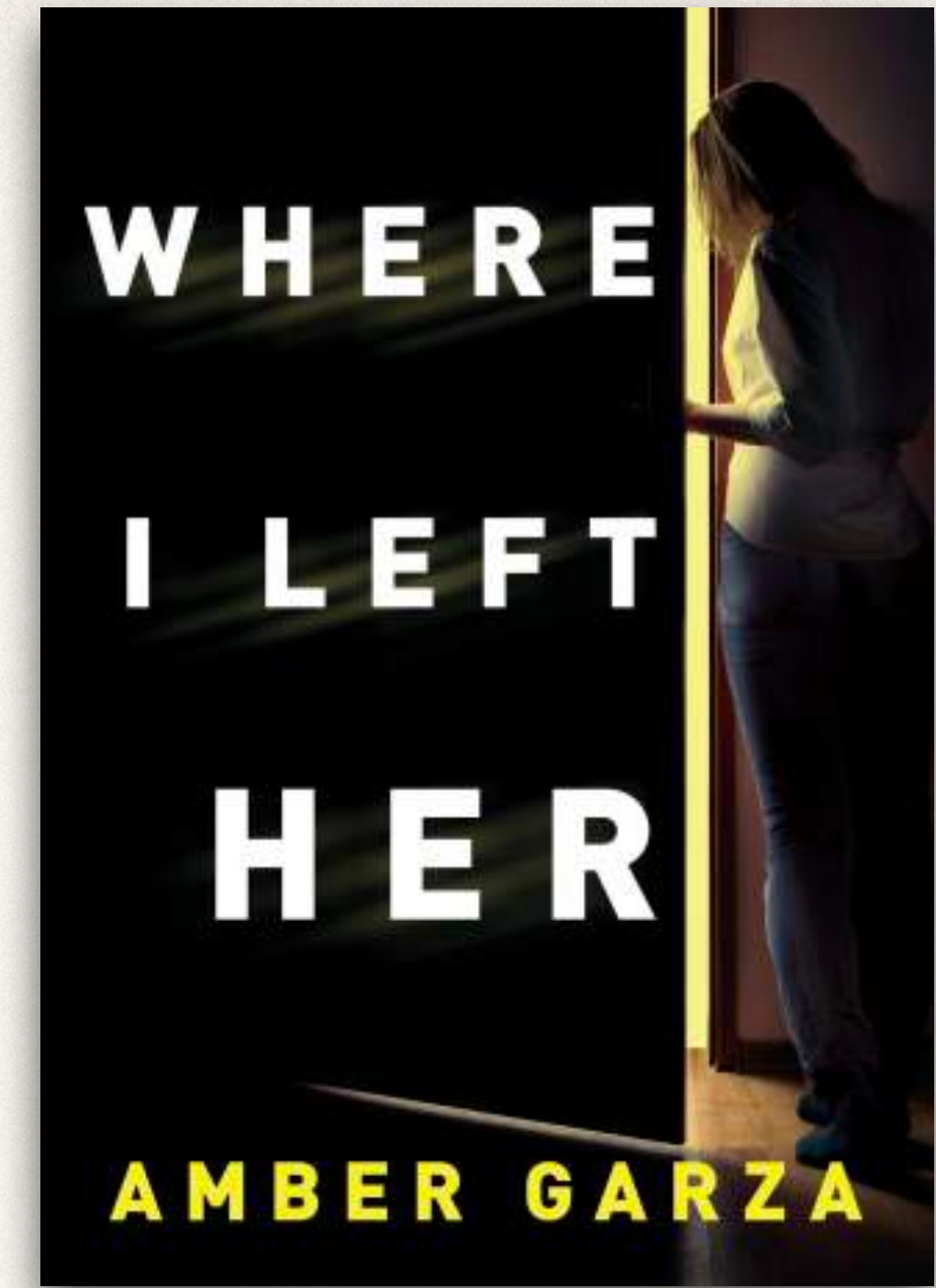

MIRA - August 24, 2021
Agent: Ellen Coughtrey

From the author of *When I Was You* comes a spine-tingling new thriller about a mother’s worst nightmare come true, when her teenage daughter goes to a sleepover and doesn’t come back.

A spine-tingling new thriller about a daughter's disappearance that received a rave, starred review from *Publishers Weekly*.

fiction

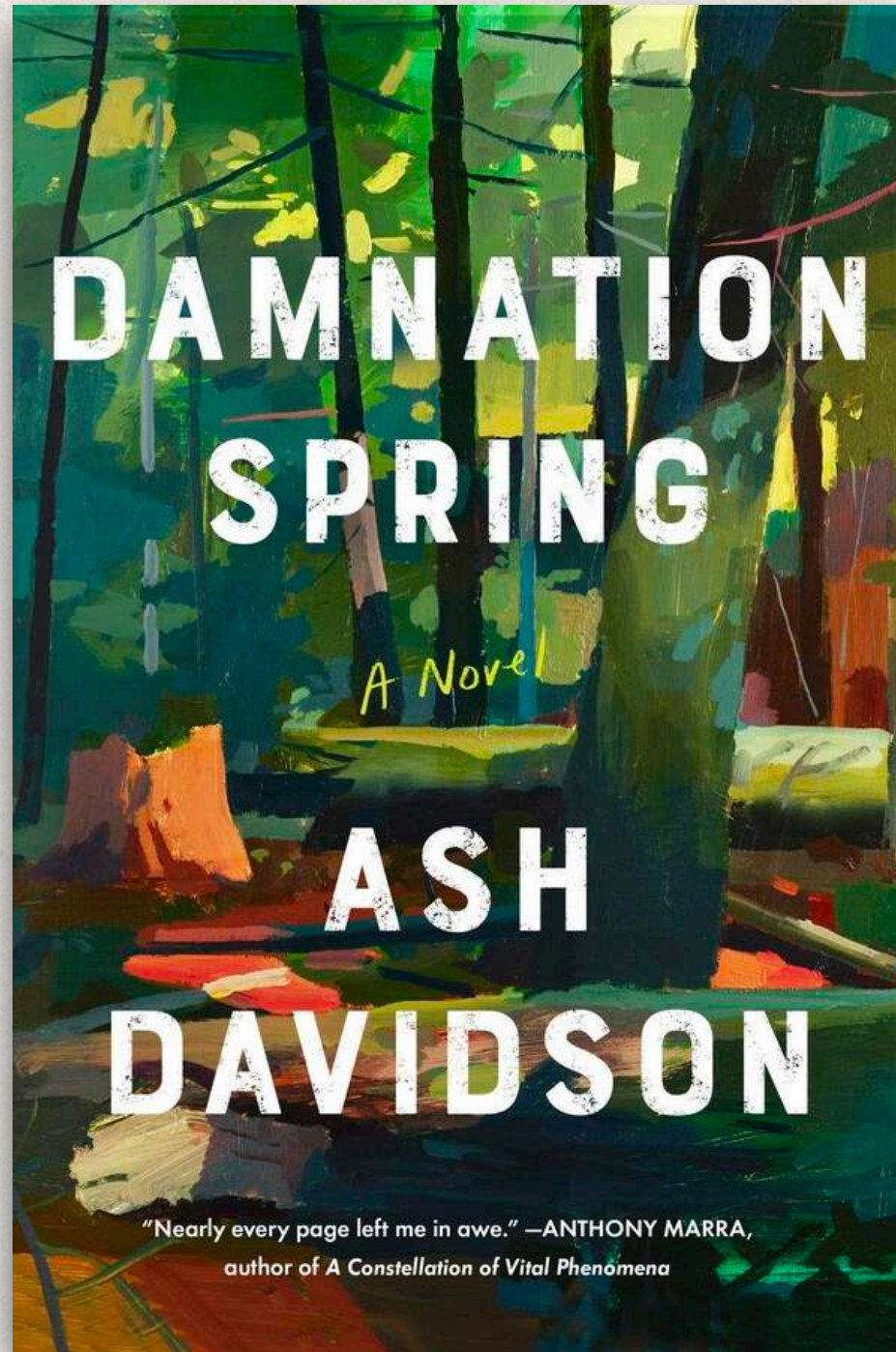

Scribner - August 3, 2021
Agent: Chris Parris-Lamb

An epic, immersive debut, *Damnation Spring* is the deeply human story of a Pacific Northwest logging town wrenched in two by a mystery that threatens to derail its way of life

National bestseller • A Most Anticipated Book: Entertainment Weekly, Oprah Daily, Vogue, Los Angeles Times, The Daily Beast, CNN, Harper's Bazaar • Rave review from *The New York Times Book Review*

fiction

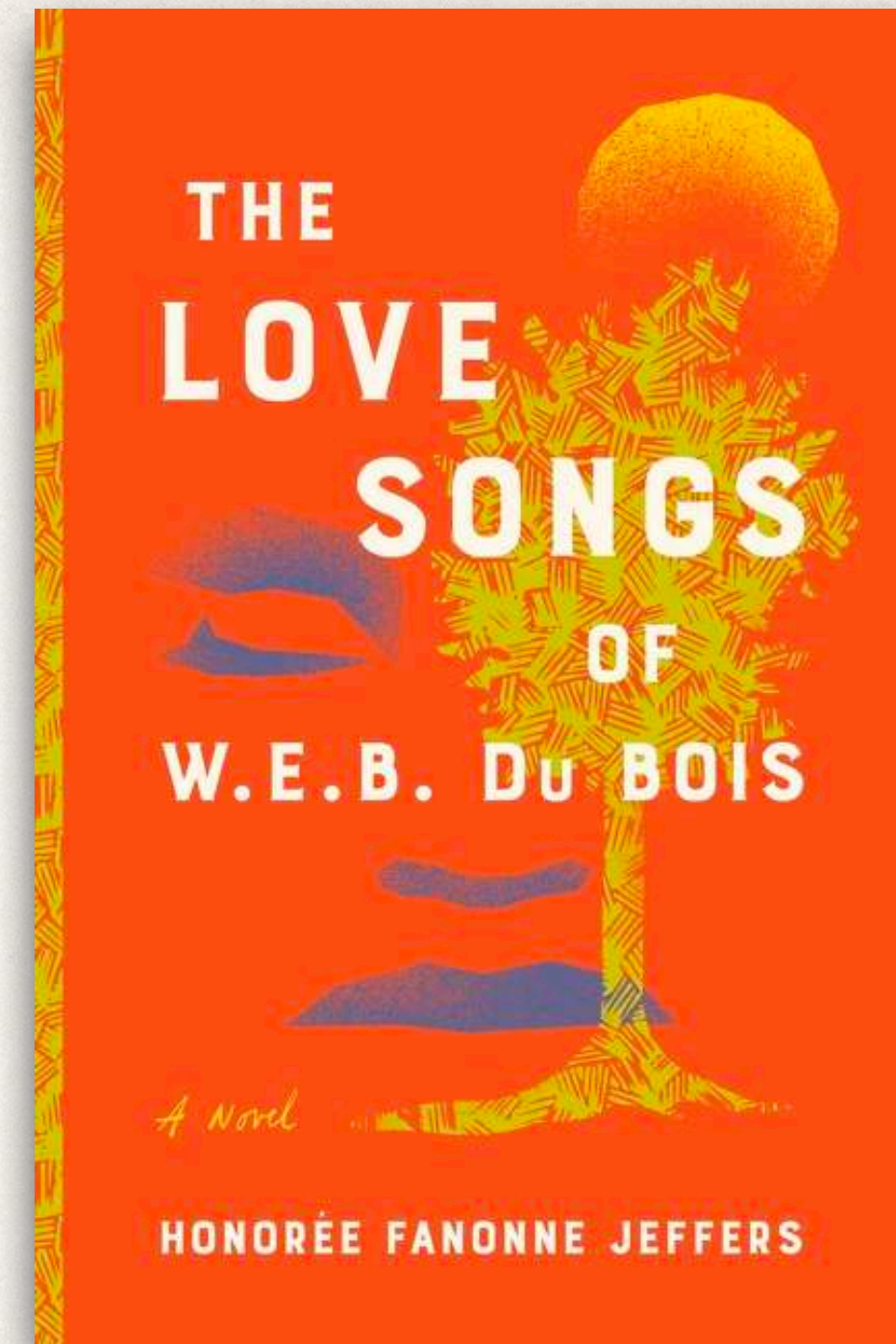

HarperCollins - August 24, 2021
Agent: Sarah Burnes

Jeffers makes her fiction debut with this magisterial epic—an intimate yet sweeping novel that chronicles the journey of one American family from the centuries of the colonial slave trade through the Civil War to our own tumultuous time.

***New York Times* bestseller • An Oprah Book Club Selection • 2020 National Book Award–nominated poet • Starred/rave reviews from PW, Booklist, Kirkus, *New York Times Book Review*, and more**

non-fiction

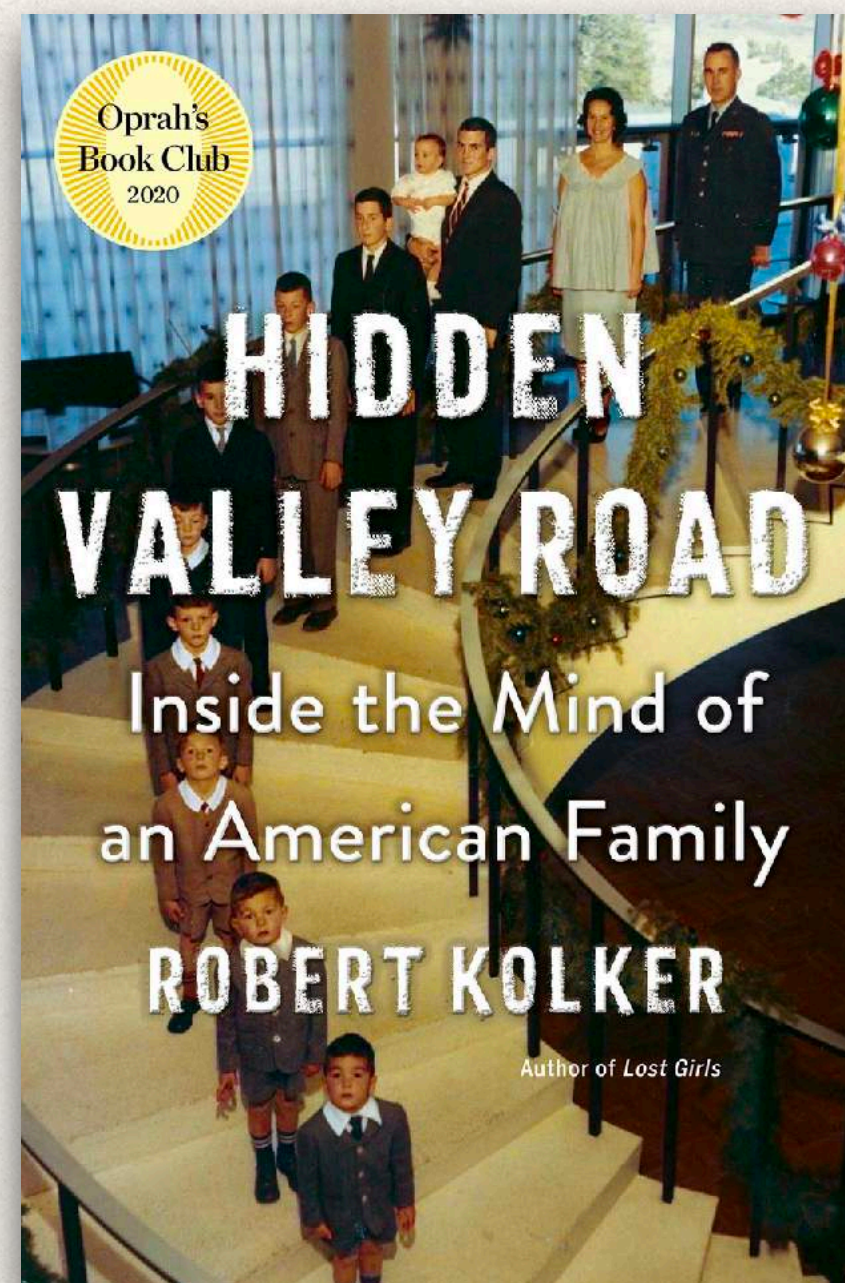

Doubleday - April 7, 2020

Agent: David Gernert & Chris Parris-Lamb

A riveting account of the Galvin family of Colorado Springs, Colorado, a midcentury American family with twelve children, six of whom were diagnosed with schizophrenia.

Oprah's Book Club Pick • #1 New York Times bestseller • One of *The New York Times* top ten books of the year • One of *The Wall Street Journal* top ten books of the year • *People's* #1 Best Book of the Year • Named a Best Book of the Year by *The Washington Post*, NPR, *TIME*, *Slate*, *Smithsonian*, and Amazon. • Eight foreign sales

non-fiction

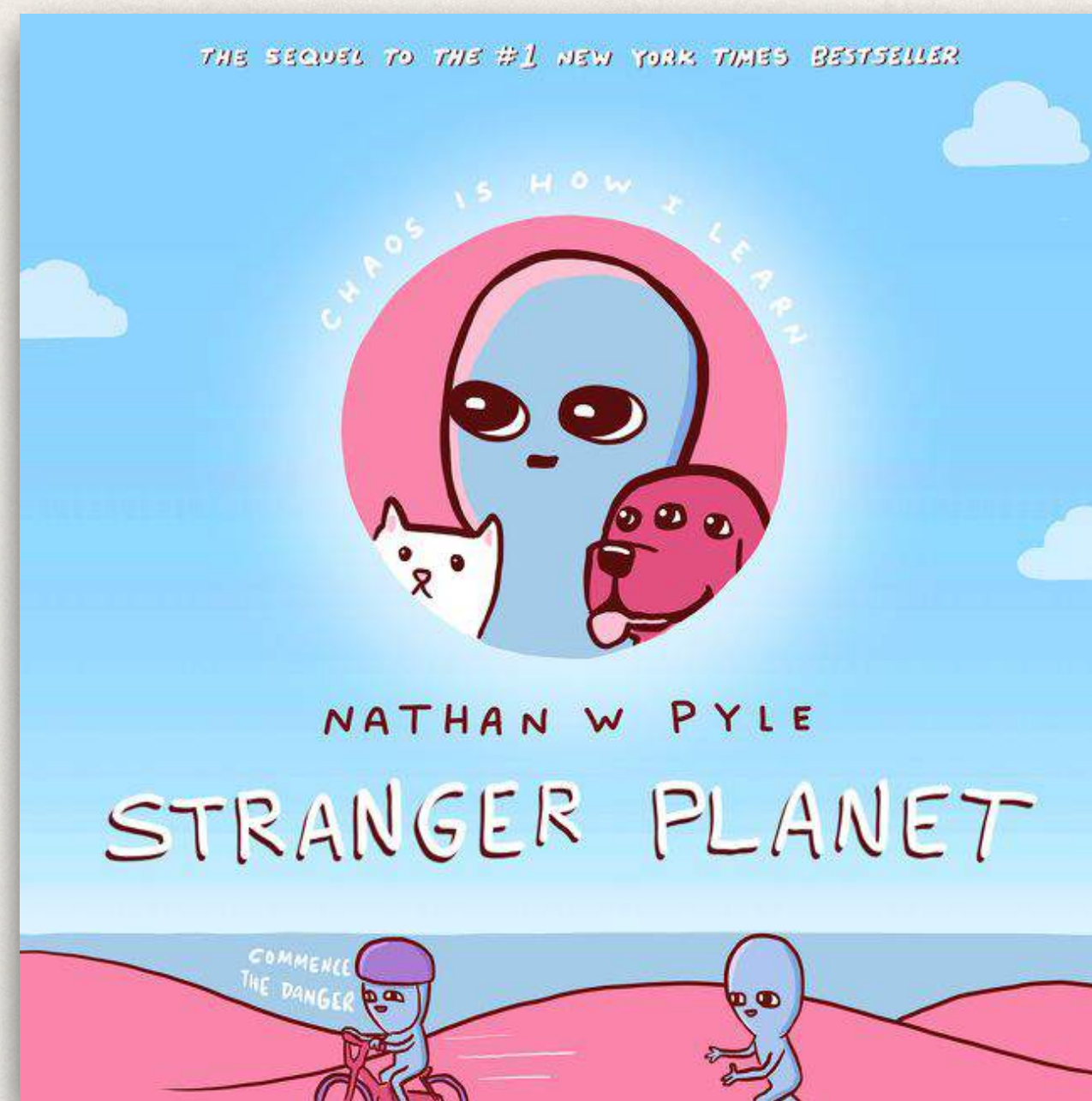

Morrow Gift - June 16, 2020

Agent: Seth Fishman

The sequel to the #1 New York Times bestselling phenomenon *Strange Planet*, featuring more hilarious adventures from the fascinating inhabitants of Nathan W. Pyle's colorful world.

#1 New York Times bestseller • More than 500,000 copies sold of the *Strange Planet* books worldwide • The graphic novel based on the Instagram sensation with more than 6.0 million followers • Television deal with Apple and Dan Harmon writing

non-fiction

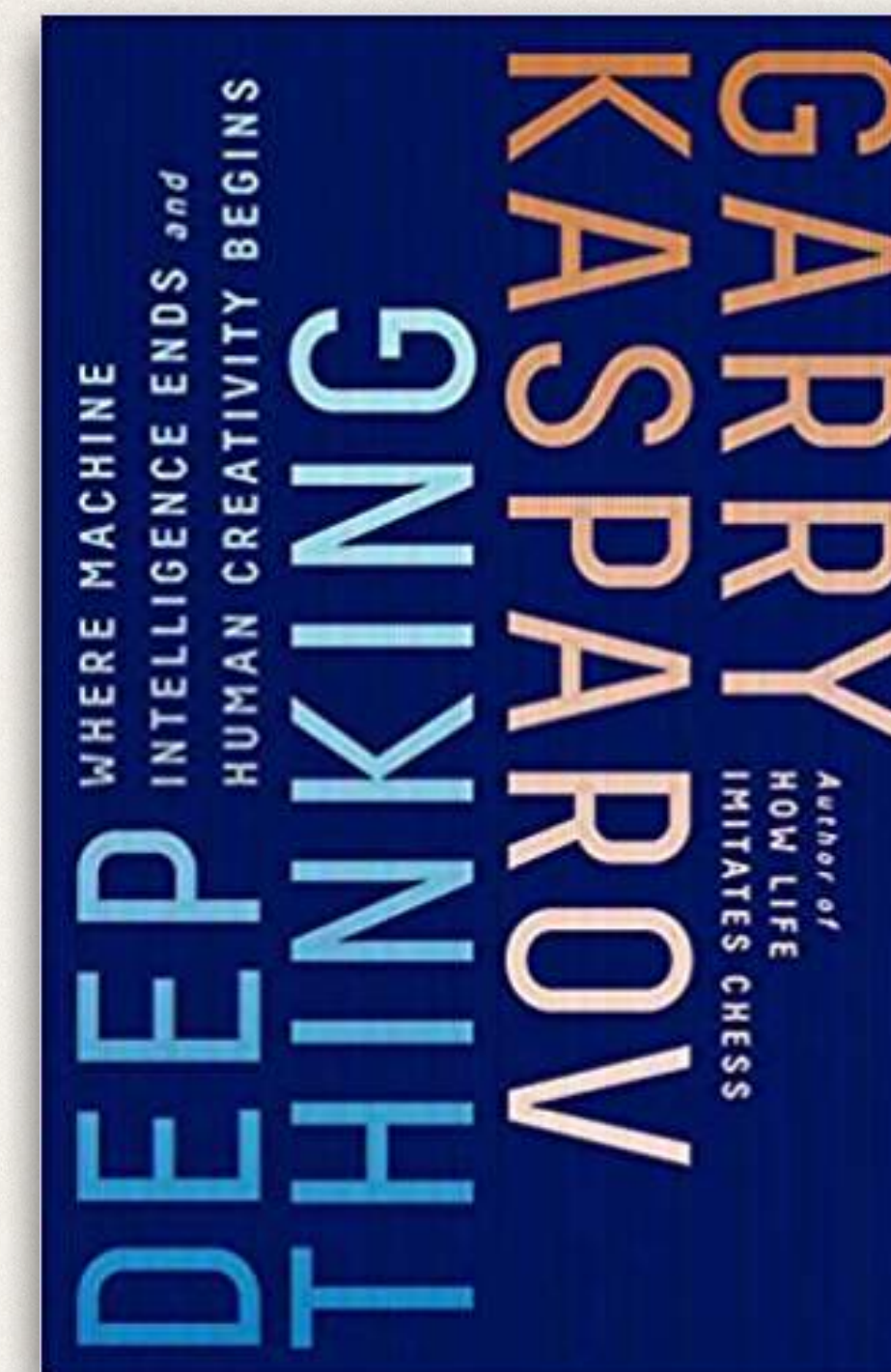

Public Affairs - May 2, 2017

Agent: Chris Parris-Lamb

Garry Kasparov's 1997 chess match against IBM supercomputer Deep Blue marked the dawn of a new era in artificial intelligence; here, he reveals his side of the story

NA rights sold in a six-figure deal • UK *Sunday Times* bestseller • "Intelligent, absorbing...Thoughtful reading for anyone interested in human and machine cognition and a must for chess fans." – *Kirkus* starred review • 13 foreign deals

non-fiction

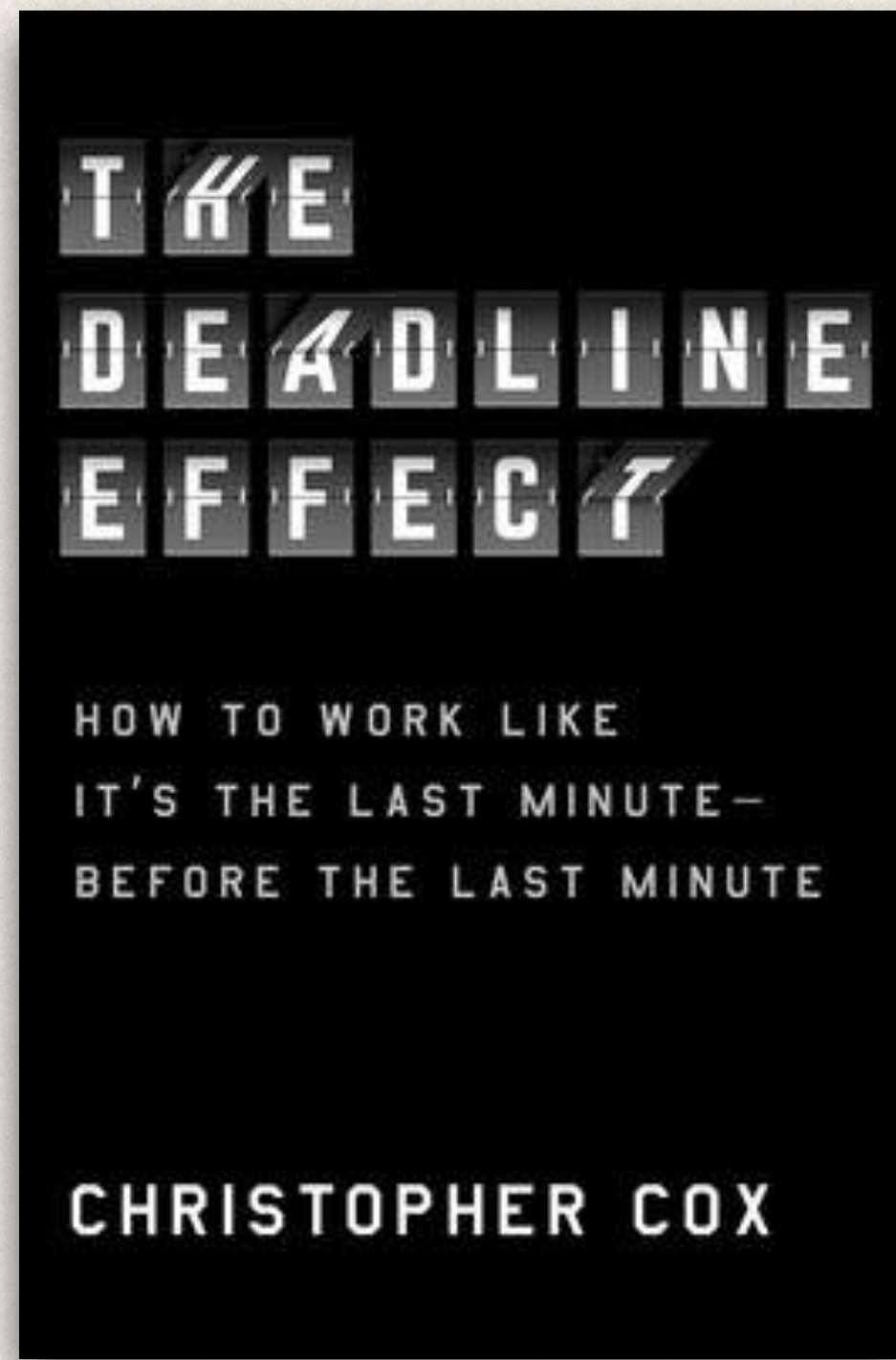

Avid Reader - July 6, 2021
Agent: Chris Parris-Lamb

In the tradition of Charles Duhigg's *The Power of Habit*, *The Deadline Effect* is a wise and counterintuitive book that explores the power of deadlines as a uniquely effective tool of motivation and empowerment.

Summer 2021 lead title for Avid Reader • 8 foreign deals

non-fiction

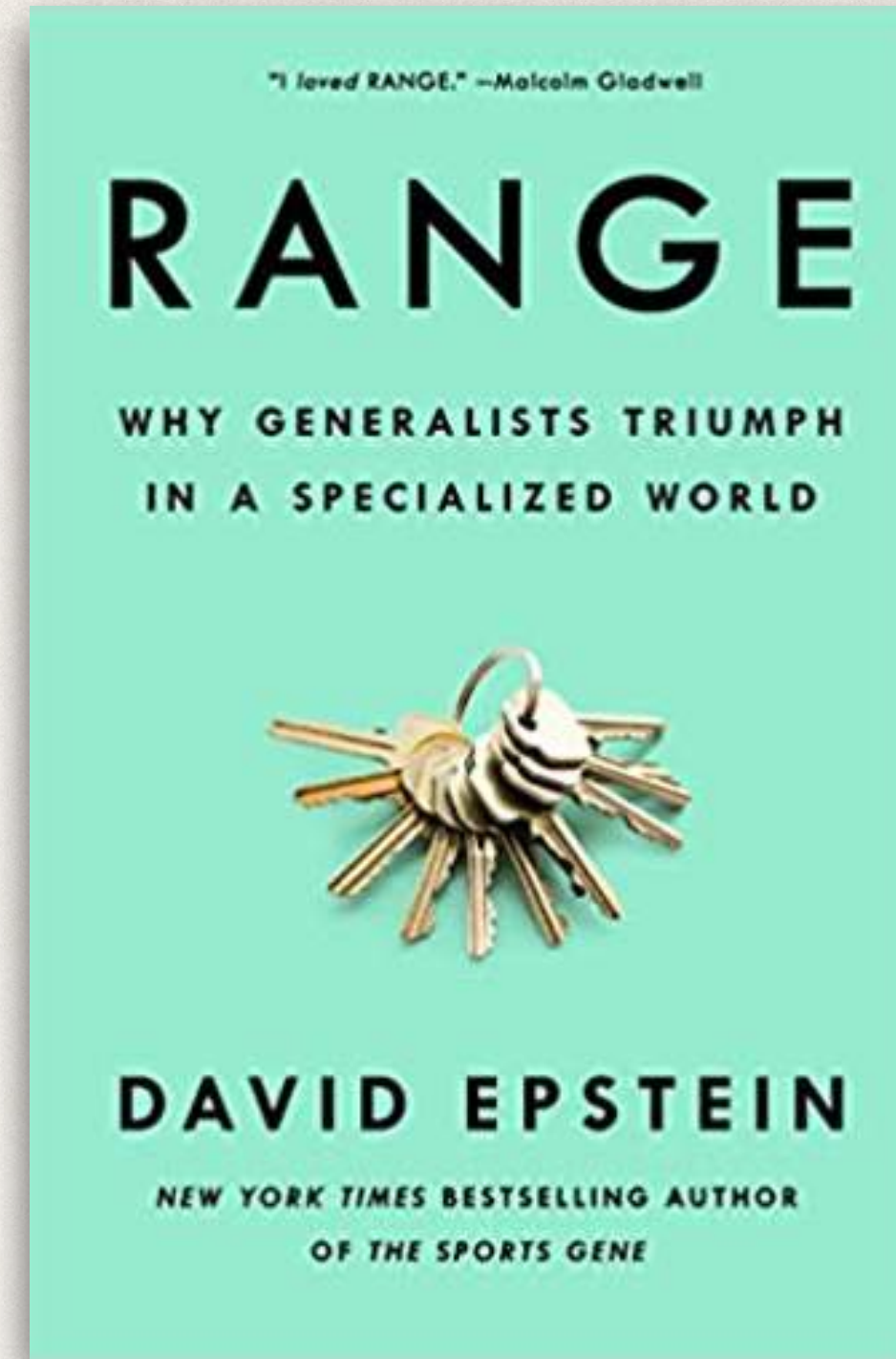

Riverhead - June 19, 2018
Agent: Chris Parris-Lamb

What's the most effective path to success in any domain?
 It's not what you think.

1 New York Times bestseller •
Sunday Times bestseller in the UK •
Shortlisted for the FT Business Book of the Year • 25 foreign deals

non-fiction

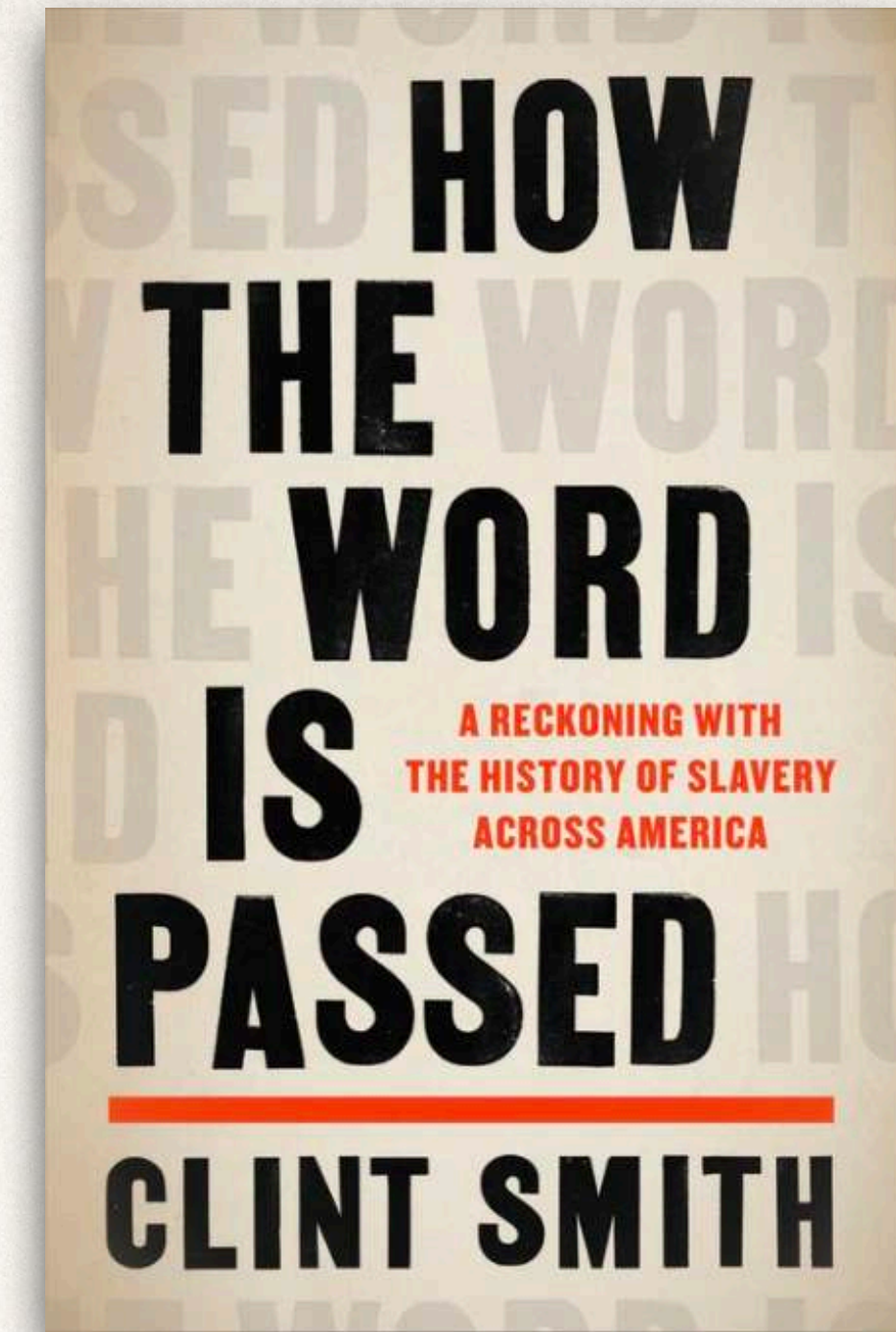

Little Brown - June 1, 2021
Agent: Alia Hanna Habib

The Atlantic staff writer and poet Clint Smith's revealing, contemporary portrait of America as a slave owning nation.

Instant #1 New York Times bestseller •
Time Best Book of Summer 2021 • A
New York Times Book Review Editor's Choice

non-fiction

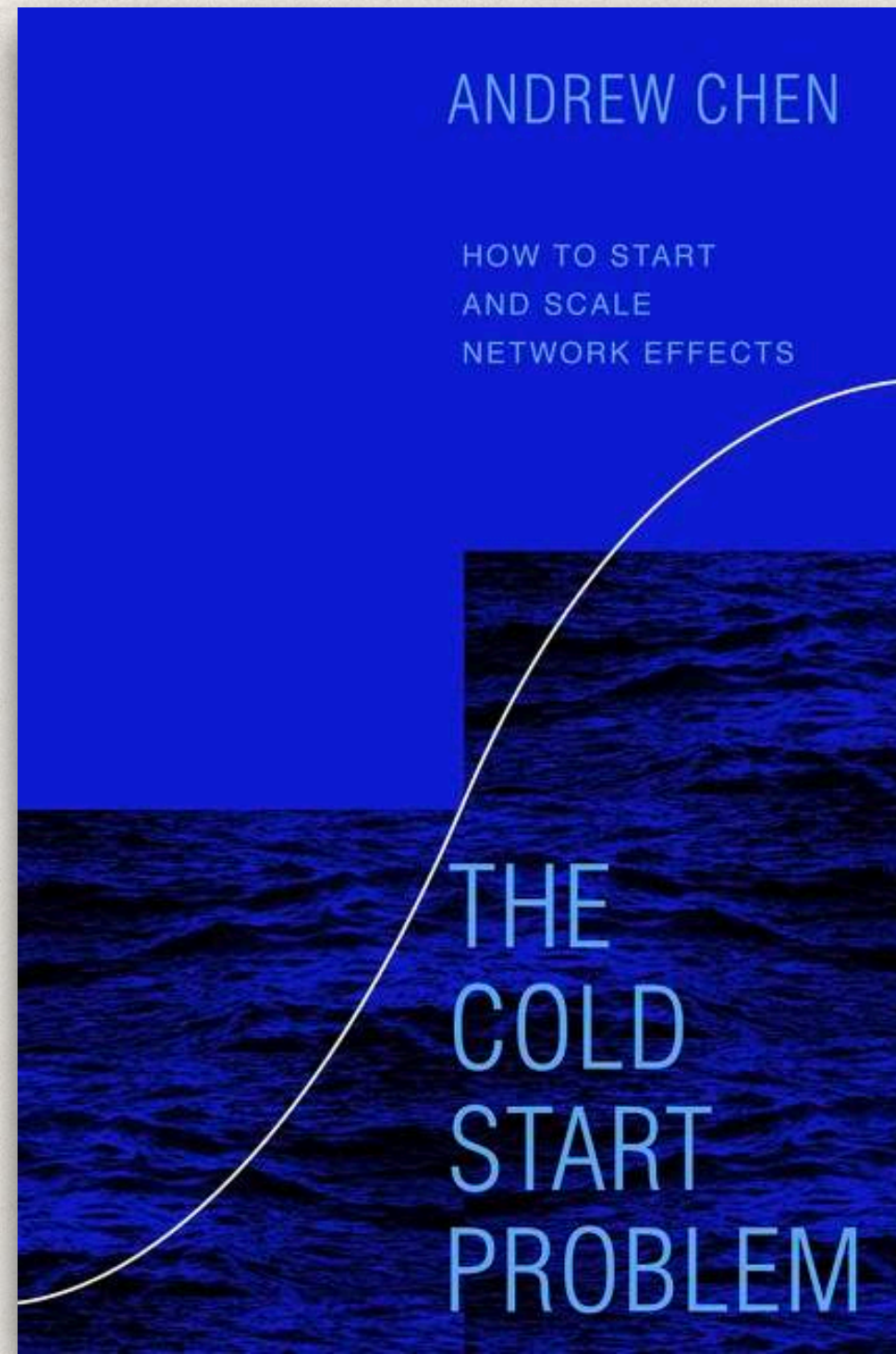

Harper Business - December 7, 2021
Agent: Chris Parris-Lamb

A startup executive draws on expertise to address how tech's most successful products have solved the dreaded "cold start problem"—by leveraging network effects to launch and scale toward billions of users.

A startup executive and investor draws on expertise developed at Andreessen Horowitz and Uber • Sold in a six-figure deal NA rights only at auction

non-fiction

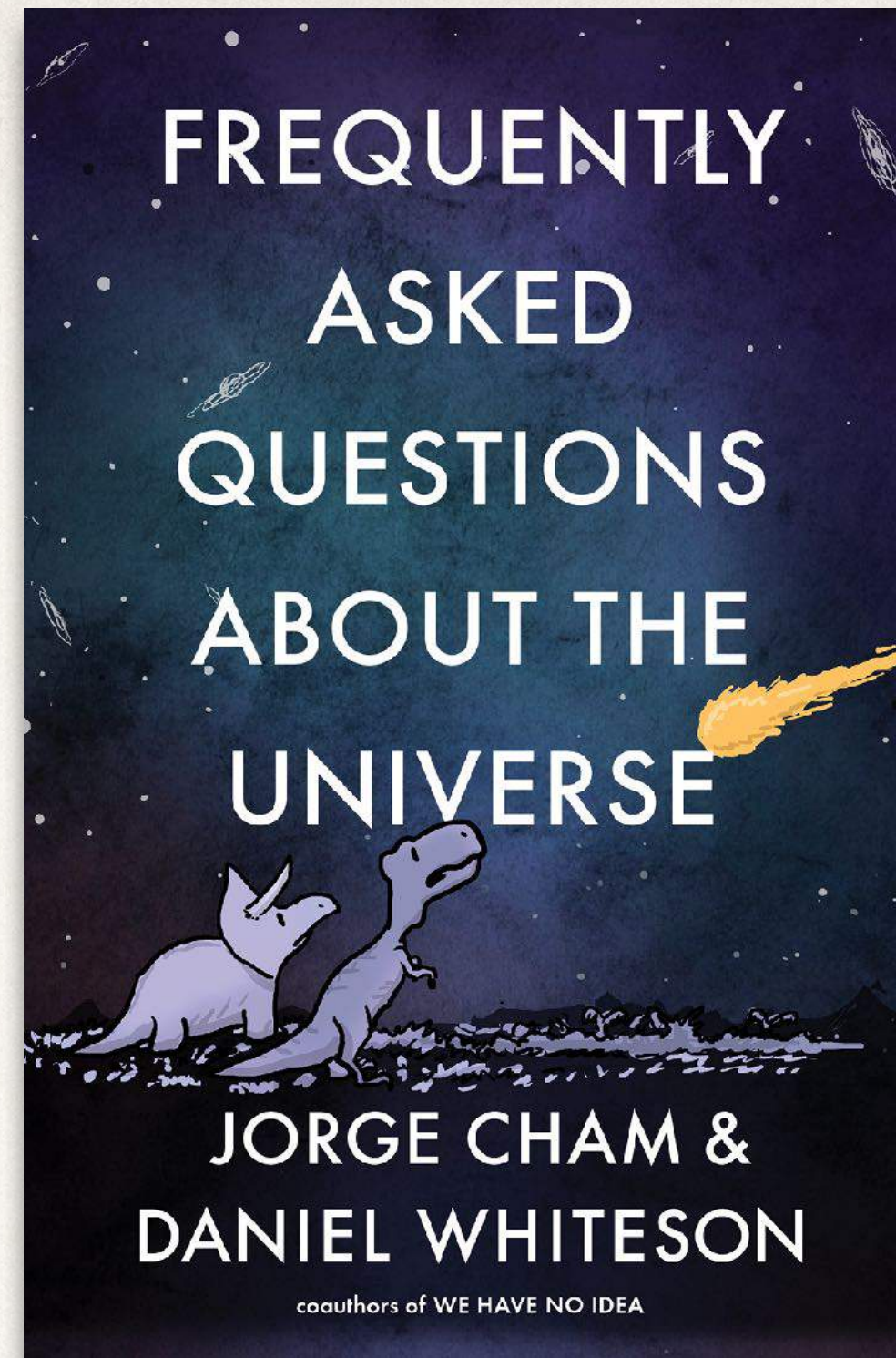

Riverhead - November 2, 2021
Agent: Seth Fishman

The authors of the beloved We Have No Idea are back with a new, illustrated book that answers the questions we all have about the universe

Sold in 11 territories • Creators of the animated series "Elinor Wonders Why" which premiered on PBS Kids in Fall 2020 • Podcast has 500,000 downloads every month

non-fiction

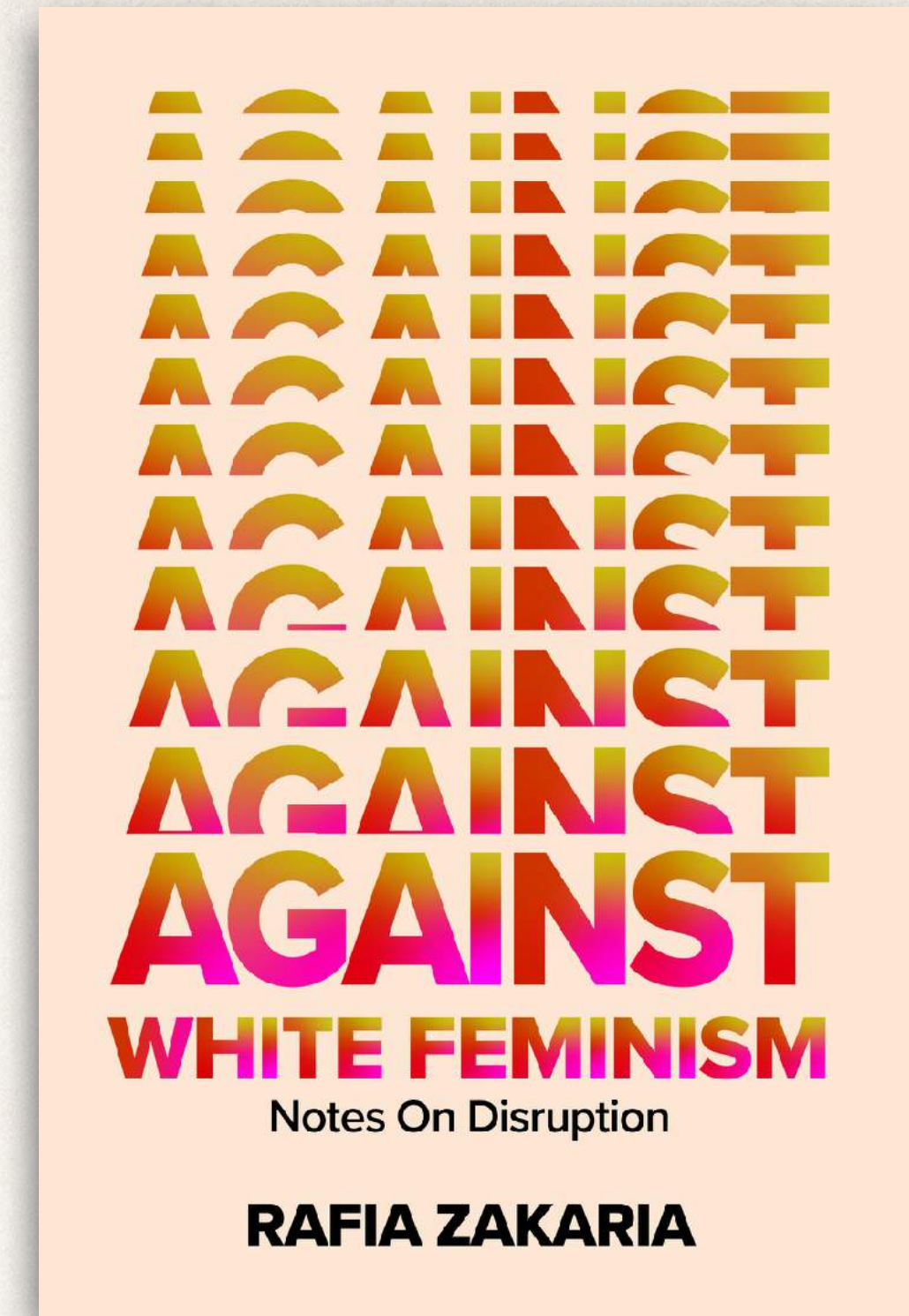

W.W. Norton - August 17, 2021
Agent: Sarah Bolling

A radically inclusive, intersectional, and transactional approach to the fight for women's rights.

Sold in at auction in the UK and preempted in Germany • A Most Anticipated Book: *Boston Globe*, *The Millions*, *TIME*, *NPR.com*, *A.V. Club*, *Essence*, *Ms. Magazine*, *Lit Hub*, *Chicago Review of Books*, *Glamour* and more

non-fiction

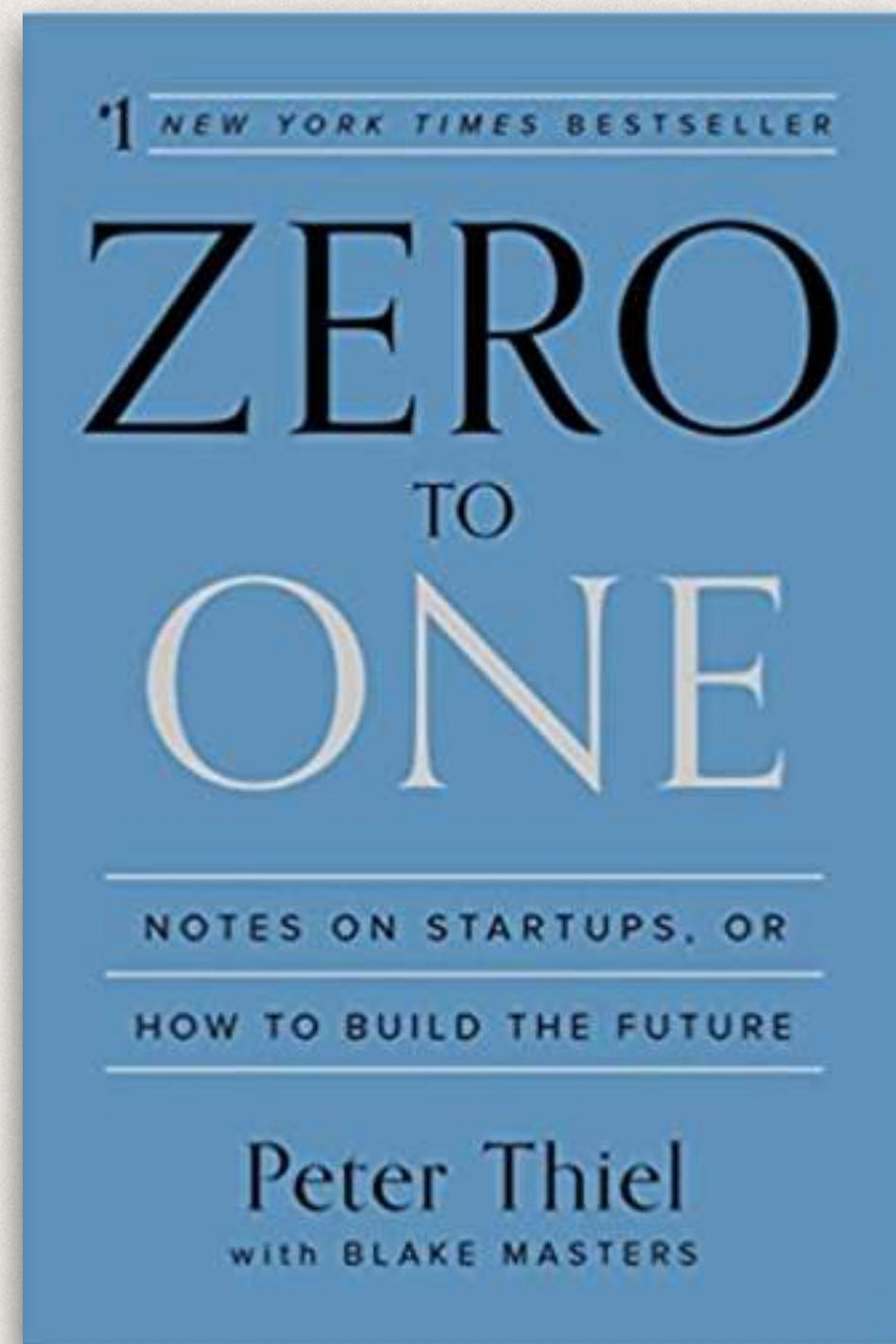

Currency - September 16, 2014
Agent: Chris Parris-Lamb

Legendary entrepreneur and investor Peter Thiel shows how we can find singular ways to explore still uncharted frontiers and create new inventions

#1 New York Times bestseller • Sold to Crown Business for seven figures in a heated auction • Huge bestseller in China • Sales in 37 foreign territories

non-fiction

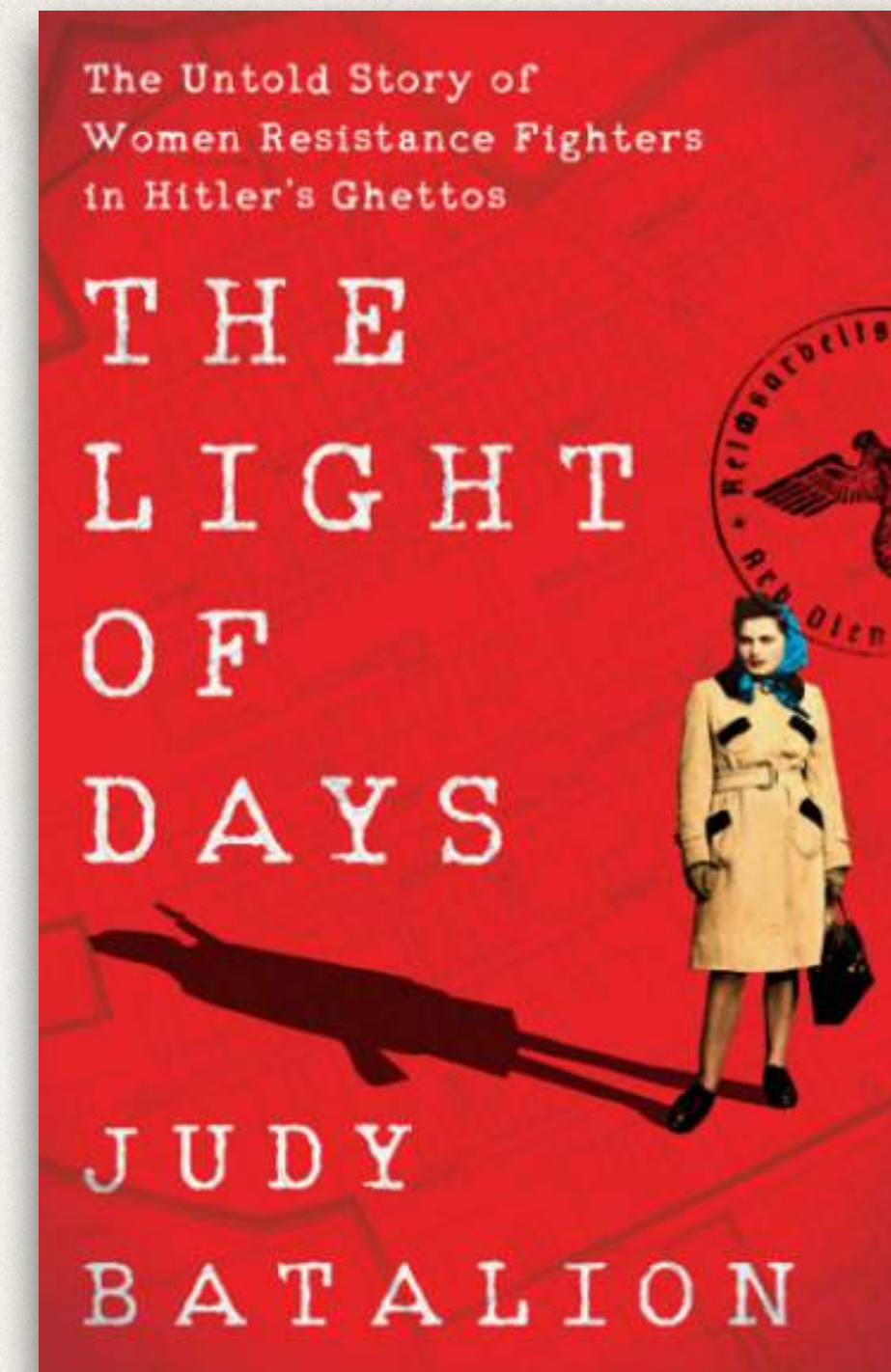

William Morrow - April 6, 2021
Agent: Alia Hanna Habib

A spectacular, searing history that brings to light the extraordinary accomplishments of brave Jewish women who became resistance fighters.

Top 5 New York Times Bestseller • Film rights optioned by Steven Spielberg • 100,000 copy first printing • 20 foreign deals

Our International Co-Agents

For queries concerning John Grisham and Louise Penny in all territories, please contact Ms. Rebecca Gardner (rgardner@thegernertco.com)

Albanian, Bulgarian, Serbian, Macedonian, Bosnian

Ms. Mira Droumeva
Andrew Nurnberg Associates Sofia
mira@anas-bg.com

Chinese, Complex and Simplified

Ms. Yu-Shiuan Chen
Bardon-Chinese Media Agency
yushiuan@bardonchinese.com

Czech, Slovak, Slovene

Ms. Petra Tobiskova
Andrew Nurnberg Associates Prague
tobiskova@nurnberg.cz

Dutch, Flemish

Ms. Marianne Schönbach
Marianne Schönbach Literary Agency
m.schonbach@schonbach.nl

Estonian, Latvian, Lithuanian, Ukrainian

Ms. Tatjana Zoldnere
Andrew Nurnberg Associates Baltic
zoldnere@ana.apollo.lv

French

Ms. Eliane Benisti
Agence Eliane Benisti
eliane@elianebenisti.com

German

Mr. Christian Dittus & Ms. Antonia Fritz
Paul & Peter Fritz AG
cdittus@fritzagency.com, afritz@fritzagency.com

Greek

Ms. Nike Davarinou – Read n Right Agency
nike@readnright.gr

Hebrew

Ms. Efrat Lev – The Deborah Harris Agency
efrat@thedeborahharrisagency.com

Hungarian, Croatian

Ms. Judit Hermann
Andrew Nurnberg Associates Budapest
j.hermann@nurnberg.hu

Indonesian

Mr. Santo Manurung – Maxima Creative
santo.maxima@gmail.com

Italian

Ms. Erica Berla – Berla & Griffini Rights Agency
berla@bgagency.it

Japanese

Mr. Ken Mori – Tuttle-Mori Agency, Inc.
ken@tuttle-mori.com

Korean

Ms. Jackie Yang – Eric Yang Agency
jackieyang@eyagency.com

Polish

Mr. Lukasz Wrobel – Graal Ltd
lukasz@graal.com.pl

Portuguese

Ms. Tassy Barham – Tassy Barham Associates
tassy@tassybarham.com

Russian

Ms. Ludmilla Sushkova
Andrew Nurnberg Associates Moscow
sushkova@awax.ru

Spanish

Ms. Teresa Vilarrubla – The Foreign Office
teresa@theforeignoffice.net

Swedish, Finnish, Danish, Norwegian, Icelandic

Ms. Trine Licht – Licht & Burr Literary Agency
tl@licht-burr.dk

Thai, Vietnamese

Mr. James Cho – Eric Yang Agency
eya-asia@eyagency.com

Turkish

Mr. Atilla Turgut – Akcali Copyright Agency
atilla@akcalicopyright.com

United Kingdom & British Commonwealth

Mr. Caspian Dennis - Abner Stein Ltd.
caspian@abnerstein.co.uk

For all other markets, contact

Rebecca Gardner (rgardner@thegernertco.com)

Will Roberts (wroberts@thegernertco.com)