

A watercolor illustration of a person standing in a grid-like structure, possibly a window or a doorway. The person is rendered in warm tones of orange and brown. The background is a mix of light blues, greens, and browns, with a grid pattern of thin lines. The overall style is soft and artistic.

# The Gernert Company

Foreign Rights Guide  
September 2023

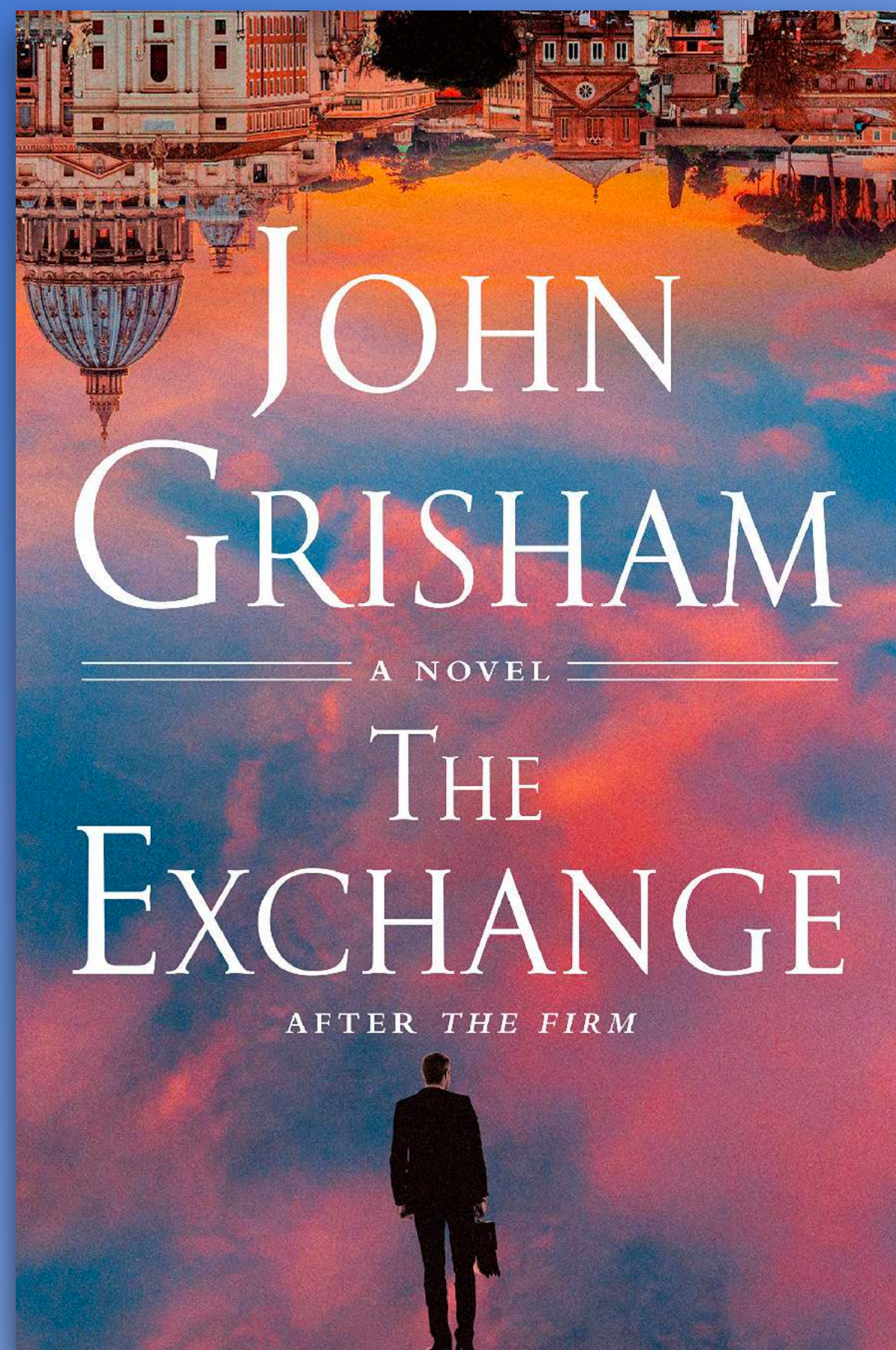

Doubleday - October 17, 2023

*#1 New York Times bestselling author John Grisham delivers high-flying international suspense in a stunning new legal thriller that marks the return of Mitch McDeere, the brilliant hero of The Firm.*

---

**John Grisham's books have sold more than 350 million copies and have been translated into nearly 50 languages and 10 blockbuster films.**

What became of Mitch and Abby McDeere after they exposed the crimes of Memphis law firm Bendini, Lambert & Locke and fled the country? The answer is in *The Exchange*, the riveting sequel to *The Firm*, the blockbuster thriller that launched the career of America's favorite storyteller.

It is now fifteen years later, and Mitch and Abby are living in Manhattan, where Mitch is a partner at the largest law firm in the world. When a mentor in Rome asks him for a favor that will take him far from home, Mitch finds himself at the center of a sinister plot that has worldwide implications—and once again endangers his colleagues, friends, and family. Mitch has become a master at staying one step ahead of his adversaries, but this time there's nowhere to hide.

**John Grisham** is a two-time winner of the Harper Lee Prize for Legal Fiction and was honored with the Library of Congress Creative Achievement Award for Fiction. His recent books include his third Jake Brigrance novel, *A Time for Mercy*, which is being developed by HBO as a limited series. When he's not writing, Grisham serves on the board of directors of the Innocent Project and of Centurion Ministries, two organizations dedicated to exonerating those who have been wrongfully convicted.

*#1 New York Times Bestseller Louise Penny*  
*whose Inspector Gamache series has sold more than 15 million copies worldwide*

---

Chief Inspector Armand Gamache, of the Sûreté du Québec, is a man who sees things others do not: the light between the cracks, the mythic in the mundane, and the evil in the seemingly ordinary. As he investigates a spate of murders in Three Pines, a seemingly idyllic village, he discovers long buried secrets and a faces a few of his own ghosts.

“A constantly surprising series that deepens and darkens as it evolves.”  
—*The New York Times Book Review*

“An outstanding, original oeuvre.”—*Wall Street Journal*

“What more could a mystery reader — or any reader, for that matter — want?”  
—*Maureen Corrigan, Washington Post*

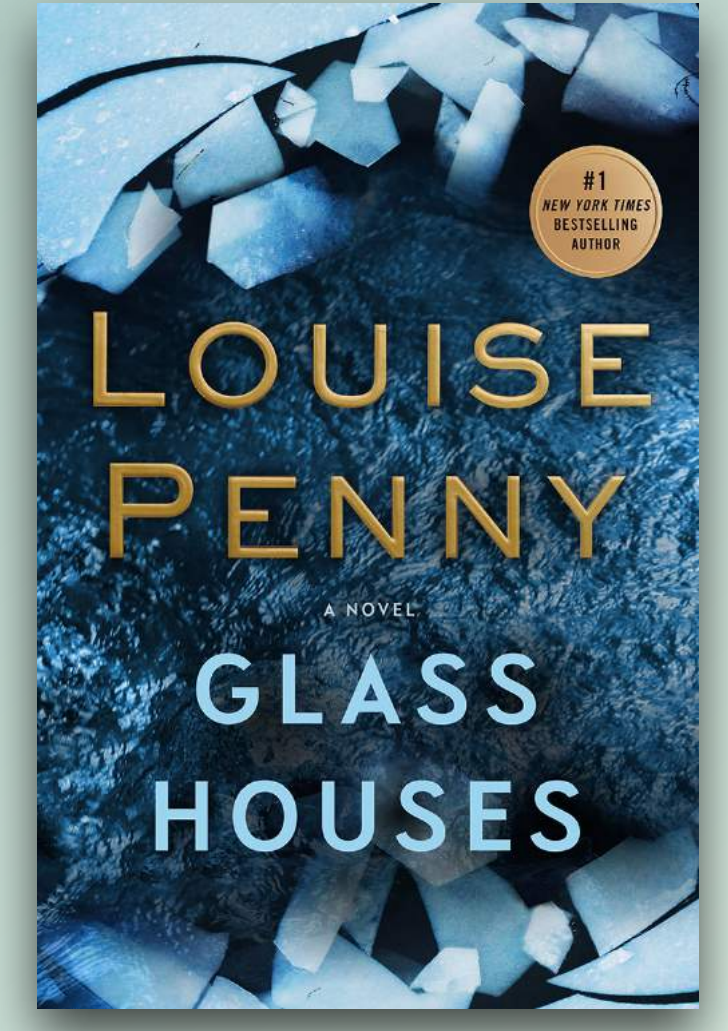
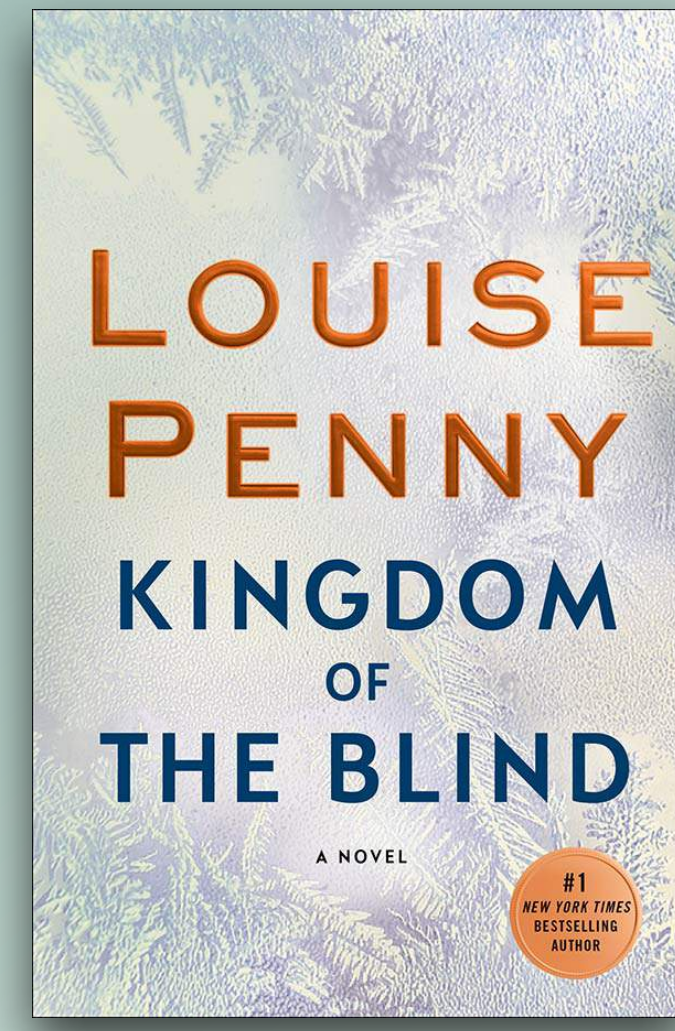
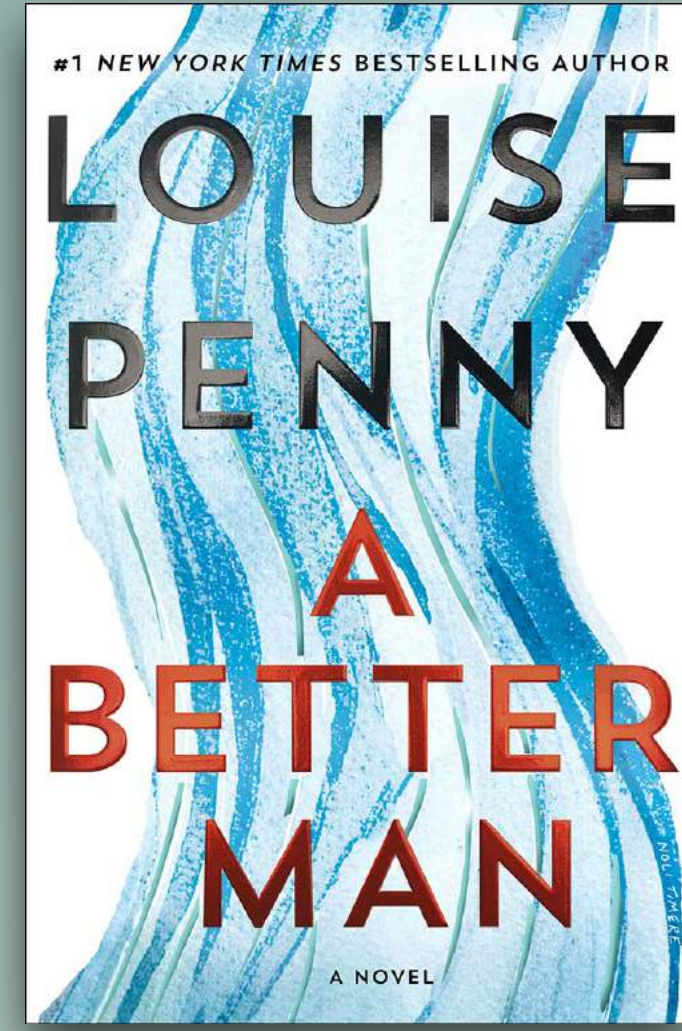
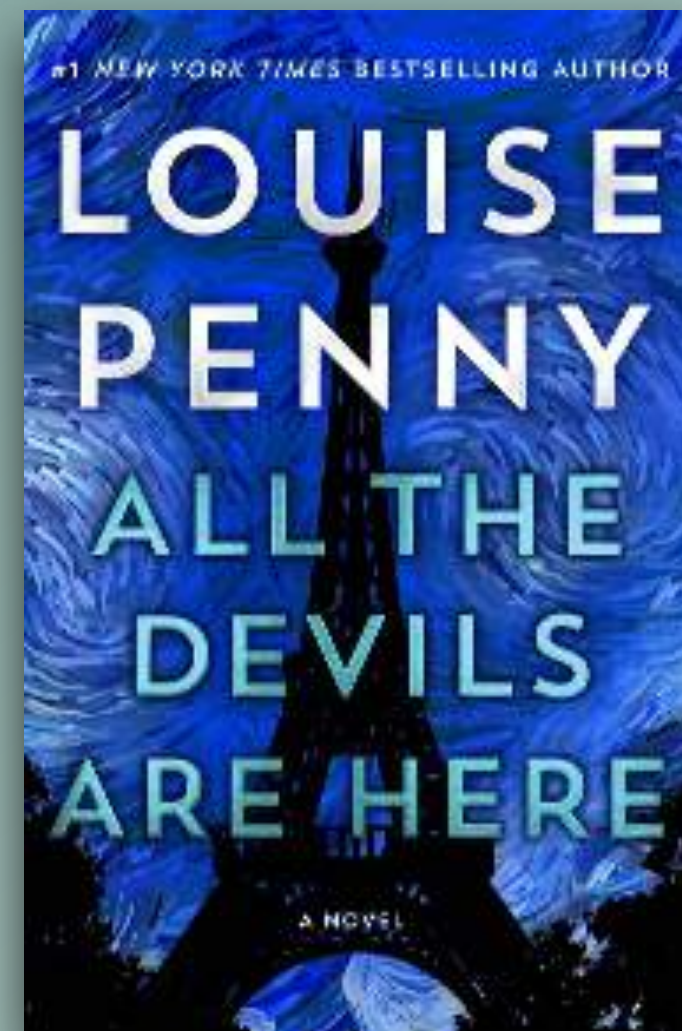
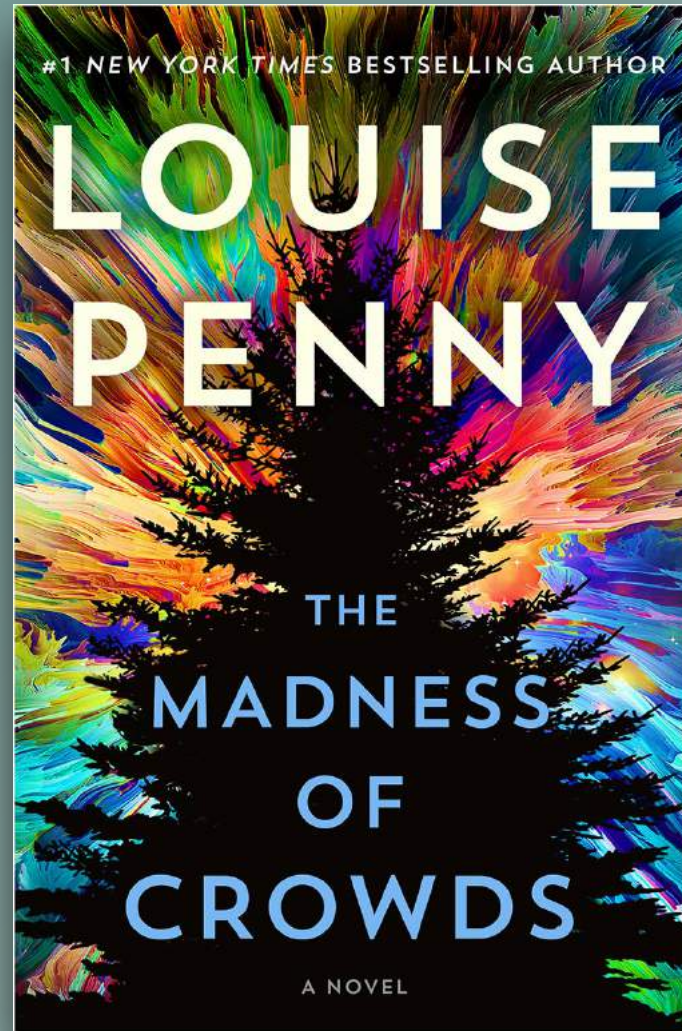
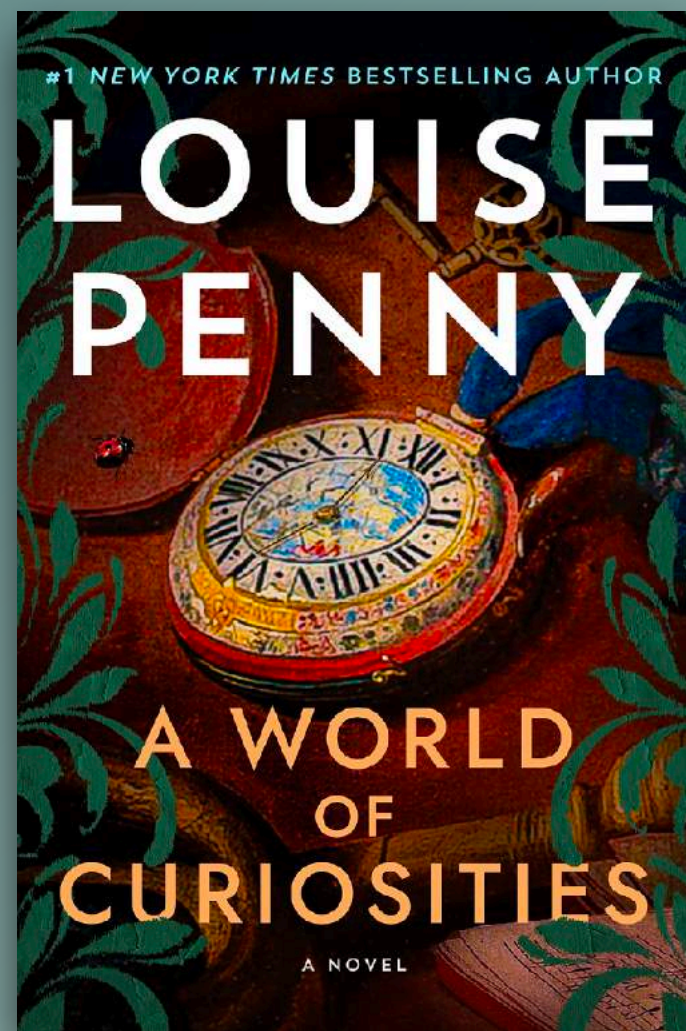

**Louise Penny** is the author of the #1 *New York Times* and *Globe and Mail* bestselling series of Chief Inspector Armand Gamache novels. She has won numerous awards, including a CWA Dagger and the Agatha Award (seven times), and was a finalist for the Edgar Award for Best Novel. In 2017, she Received the Order of Canada for her contributions to Canadian culture. Louise lives in a small village south of Montréal.

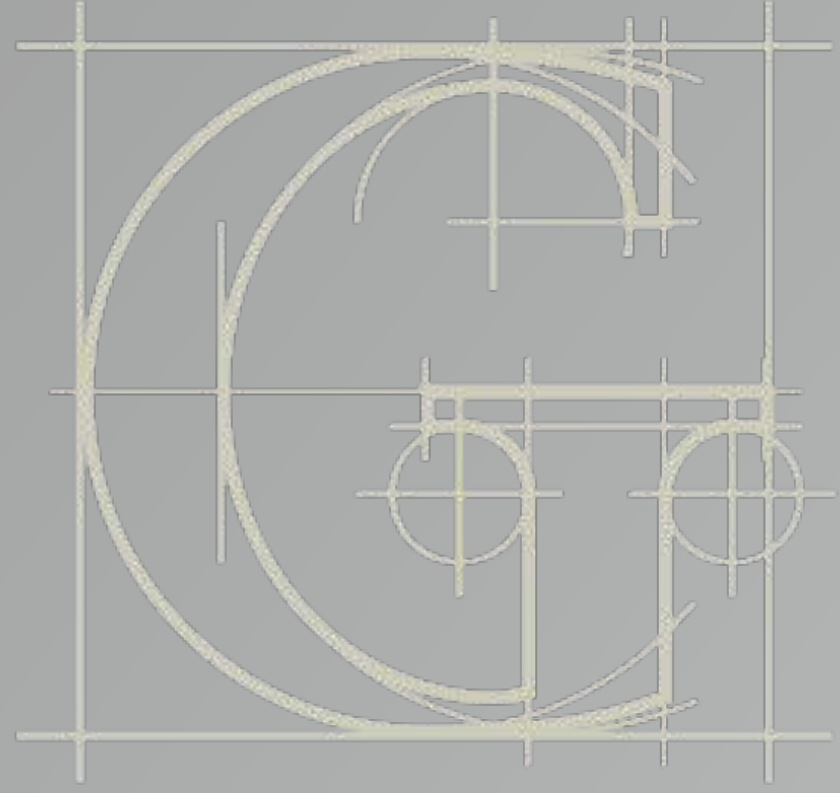

*the*  
**gernert**  
*company*

***FICTION***

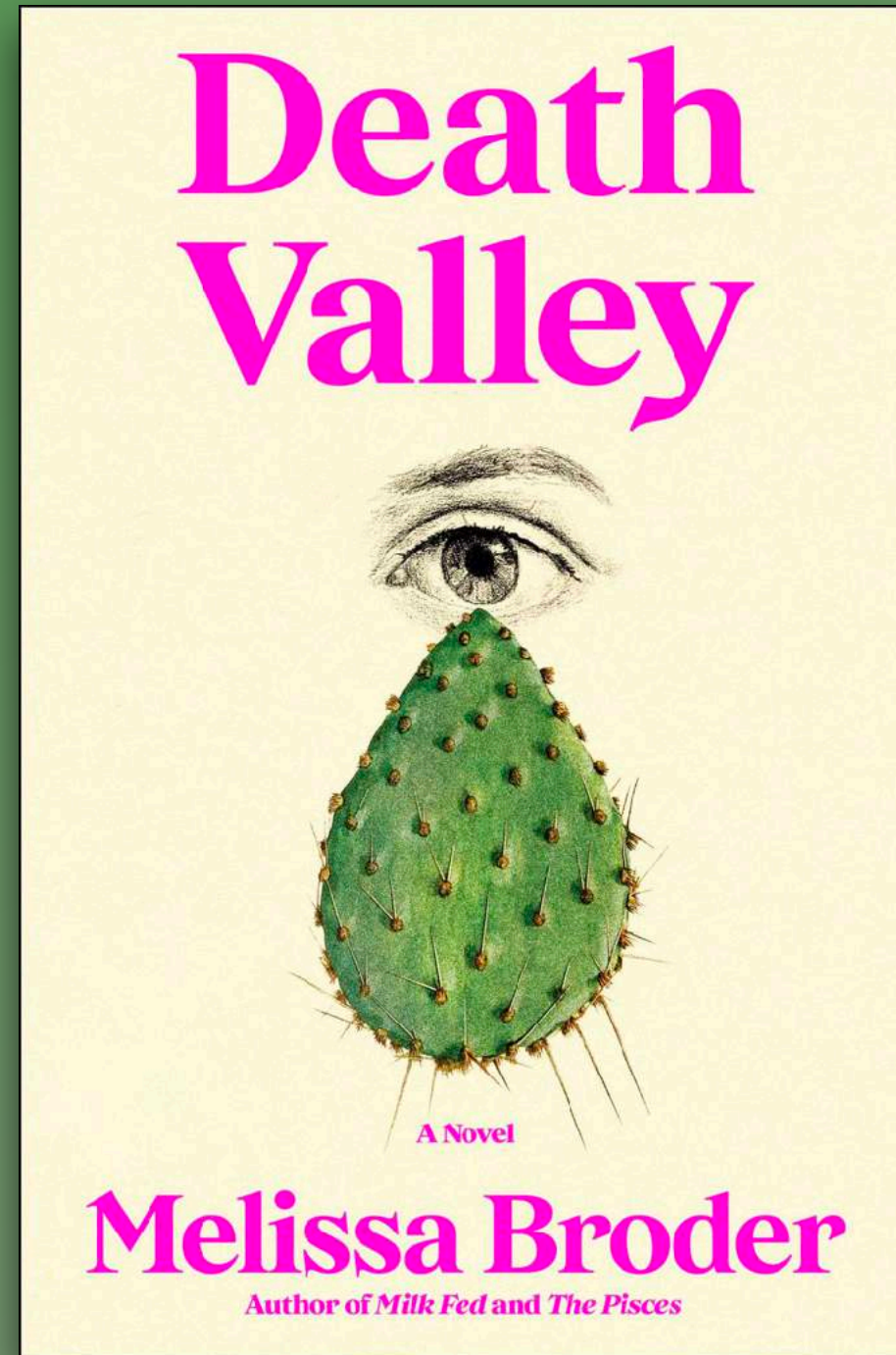

Scribner - October 24, 2023

[literary](#) | [existential](#) | [dark humor](#)

**Rights sold:**

**Bloomsbury (UK & BC)**

*Editor:* Kara Watson

*Agent:* Meredith Kaffel Simonoff

*Material:* Final pages

*The most profound book yet from the visionary author of Milk Fed and The Pisces, a darkly funny novel about grief that becomes a desert survival story.*

**#1 Indie Next Pick**

“Infections and dreamy...Broder’s narrator is consistently companionable...Readers ought not to miss this magical tale of survival.” —**Publishers Weekly, *\*starred review\****

“As wise in its way as any spiritualism about vision quests or finding enlightenment...A 100 percent Border take on grief and empathy, embodied but cerebral, hilarious but heart-wrenching.” —**Kirkus**

“A journey unlike any you’ve read before. *Death Valley* is a beautifully wild leap into the mysterious desert that is grief.” —**Nana Kwame Adjei-Brenyah, author of *Chain-Gang All-Stars* and *Friday Black***

“Broder’s writing is a brilliant, zany compass leading us from the sorrow of existence toward the hilarity of someday having to die.” —**Hilary Leichter, author of *Terrace Story***

“Melissa Broder captures both the punishing ordinariness of loss while also showing us how extraordinary it is to have been here at all. There is deep wisdom in these pages.”

—**Mary Beth Keane, author of *Ask Again, Yes***

In Melissa Broder’s astounding new novel, a woman arrives alone at a Best Western seeking respite from an emptiness that plagues her. She has fled to the California high desert to escape a cloud of sorrow—for both her father in the ICU and a husband whose illness is worsening. What the motel provides, however, is not peace but a path, thanks to a receptionist who recommends a nearby hike. Out on the sun-scorched trail, the woman encounters a towering cactus whose size and shape mean it should not exist in California. Yet the cactus is there, with a gash through its side that beckons like a familiar door. So she enters it. What awaits her inside this mystical succulent sets her on a journey at once desolate and rich, hilarious and poignant. This is Melissa Broder at her most imaginative, most universal, and finest. This is *Death Valley*.

**Melissa Broder** is the author of the novels MILK FED and THE PISCES, the essay collection SO SAD TODAY, and five poetry collections, including SUPERDOOM: Selected Poems (Summer 2021) and LAST SEXT. Broder has written for *The New York Times*, *Elle.com*, *VICE*, *Vogue Italia*, and *New York Magazine’s* The Cut.

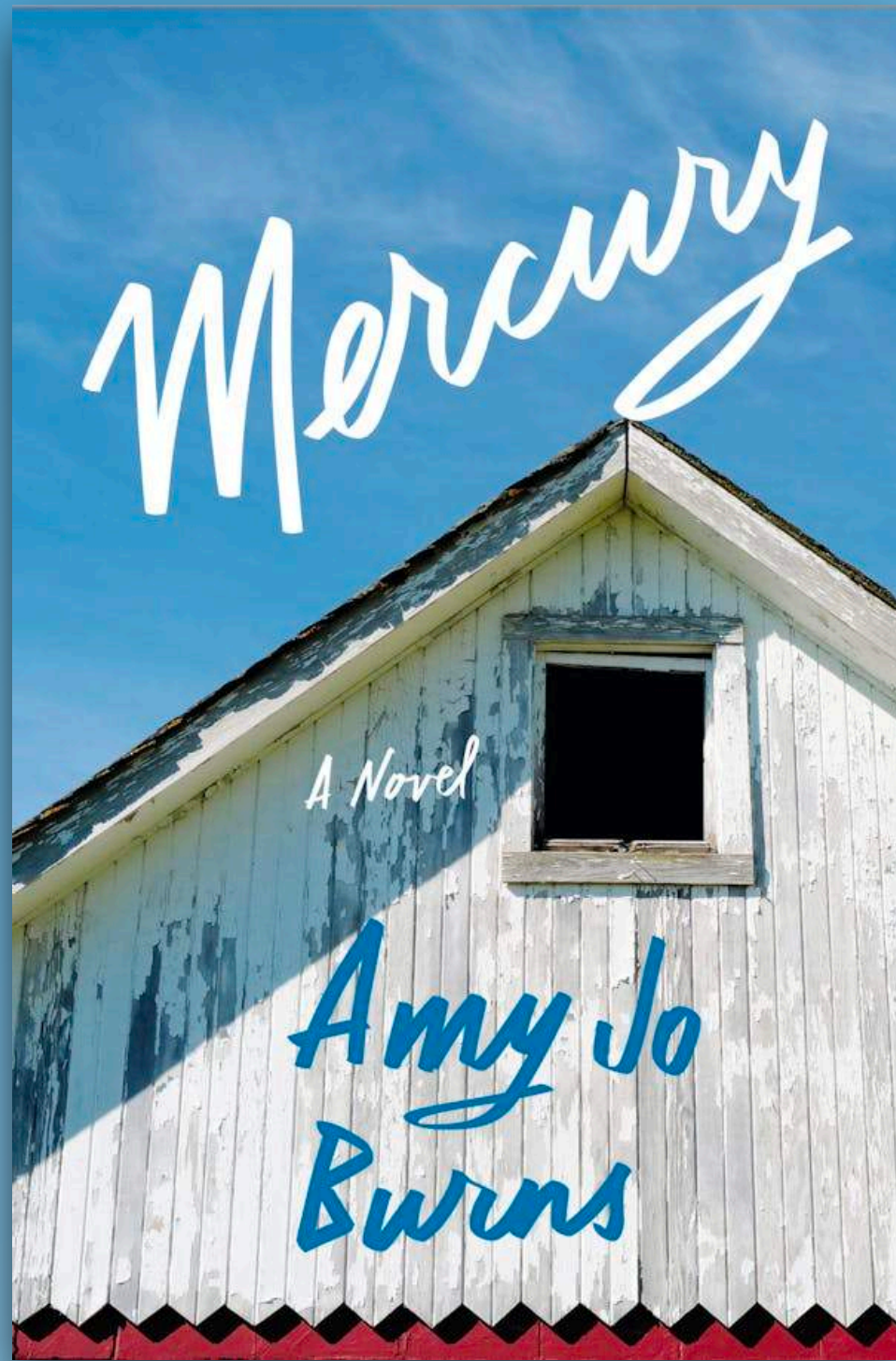

Celadon Books - January 30, 2024

[upmarket fiction](#) | [family](#) | [coming of age](#)

**Editor:** Deb Futter

**Agent:** Meredith Kaffel Simonoff

**Material:** 2nd pass pages

*A roofing family's bonds of loyalty are tested when they uncover a long-hidden secret at the heart of their blue-collar town—from Amy Jo Burns, author of the critically acclaimed novel Shiner*

---

"Mercury shimmers with authenticity. Amy Jo Burns is a big-time talent whose beautiful and honest prose elevates love, even when plumbing the darker realities of family. Tears streamed down my face as I turned the last page. An instant favorite." —**Matthew Quick, New York Times bestselling author of *The Silver Linings Playbook* and *We Are the Light***

"It just doesn't get any better than this when it comes to a story about what it means to be family, whether it's the one you're born into or the one you create. You will fall in love with these beautifully drawn, unforgettable characters, who remind us of the strength of family bonds, and the importance of grace and forgiveness."

—**Tracey Lange, New York Times bestselling author of *We Are the Brennans***

"Mercury is part family saga, part mystery, and 100% unputdownable. As the secrets piled up and discoveries were made, I read faster and faster, eager to unravel the web Amy Jo Burns so masterfully wove. Surprising and true, Mercury reminds us of the importance of love and forgiveness."

—**Ann Hood, author of *The Knitting Circle* and *The Book That Matters Most***

It's 1990 and seventeen-year-old Marley West is blazing into the river valley town of Mercury, Pennsylvania. A perpetual loner, she seeks a place at someone's table and a family of her own. The first thing she sees when she arrives in town is three men standing on a rooftop. Their silhouettes blot out the sun. The Joseph brothers become Marley's whole world before she can blink. Soon, she is young wife to one, The One Who Got Away to another, and adopted mother to them all. As their own mother fades away and their roofing business crumbles under the weight of their unwieldy father's inflated ego, Marley steps in to shepherd these unruly men. Years later, an eerie discovery in the church attic causes old wounds to resurface and suddenly the family's survival hangs in the balance. With Marley as their light, the Joseph brothers must decide whether they can save the family they've always known—or whether together they can build something stronger in its place.

**Amy Jo Burns** is the author of the memoir *Cinderland* and the novel *Shiner*. Her writing has appeared in *Elle*, *Good Housekeeping*, *The Paris Review Daily*, and the anthology *Not That Bad*. A western Pennsylvania native, she now lives in New Jersey with her family.



St. Martins - August 8, 2023

[thriller](#) | [psychological](#) | [influencer](#)

**Rights sold:**

**Penguin (ANZ), Canelo (UK & BC)**

**ERA Media (Bulgaria)**

*Editor:* Charlie Spicer

*Agent:* David Gernert

*Material:* Final pages

*She can't see what she fears the most. A true crime podcaster returns to search for a popular influencer who disappears after visiting a suspected serial killer.*

---

### **Book of the Month Pick**

“A gripping story that is equal parts shocking, unnerving and thrilling. Goldin takes the “true crime” trope to new and unexpected territory.” —**Karin Slaughter, *New York Times* and #1 international bestselling author of *Girl, Forgotten***

“Goldin keeps readers on their toes, offering tantalizing clues to what’s really going on but keeping the truth a closely-guarded secret until it’s time to reveal it. A third Rachel Krall novel would be most welcome.” —**Booklist**

“An intriguing dive into the dark and mysterious world of social media influencers. The riveting plot and twists kept me turning pages until the jaw-dropping conclusion.”  
—**Frieda McFadden, *New York Times* bestselling author of *The Housemaid***

Terence Bailey is about to be released from prison, though investigators have long suspected him in the murders of six women. As his release date approaches, Bailey gets a surprise visit from Maddison Logan, a hot, young influencer with a huge social media following. Hours later, Maddison disappears, and police suspect she’s been kidnapped. Is Maddison’s disappearance connected to her visit to Bailey? Maddison seems to only exist on social media; she has no family, no friends, and other than in her posts, most people have never seen her. Who is she, really? When they hit a wall in the investigation, the FBI reluctantly reach out to the acclaimed podcaster / investigator Rachel Krall for help in finding the missing influencer. Using a fake Instagram account, Rachel goes undercover to BuzzCon, a popular influencer conference, where she discovers a world of fierce rivalry that may have turned lethal. When police find the body of a woman with a tattoo identical to one Rachel had seen on Bailey’s hand, the FBI must consider the chilling possibility that Bailey has an accomplice on the outside and a dangerous obsession with influencers. Suddenly the target of a monster hiding in plain sight, Rachel is forced to confront the very real dangers that lurk in the dark corners of the internet.

**Megan Goldin**, author of *Stay Awake*, *The Escape Room* and *The Night Swim*, worked as a correspondent for Reuters and other media outlets where she covered war, peace, international terrorism and financial meltdowns. She is now based in Melbourne, Australia where she raises three sons and is a foster mum to Labrador puppies learning to be guide dogs.

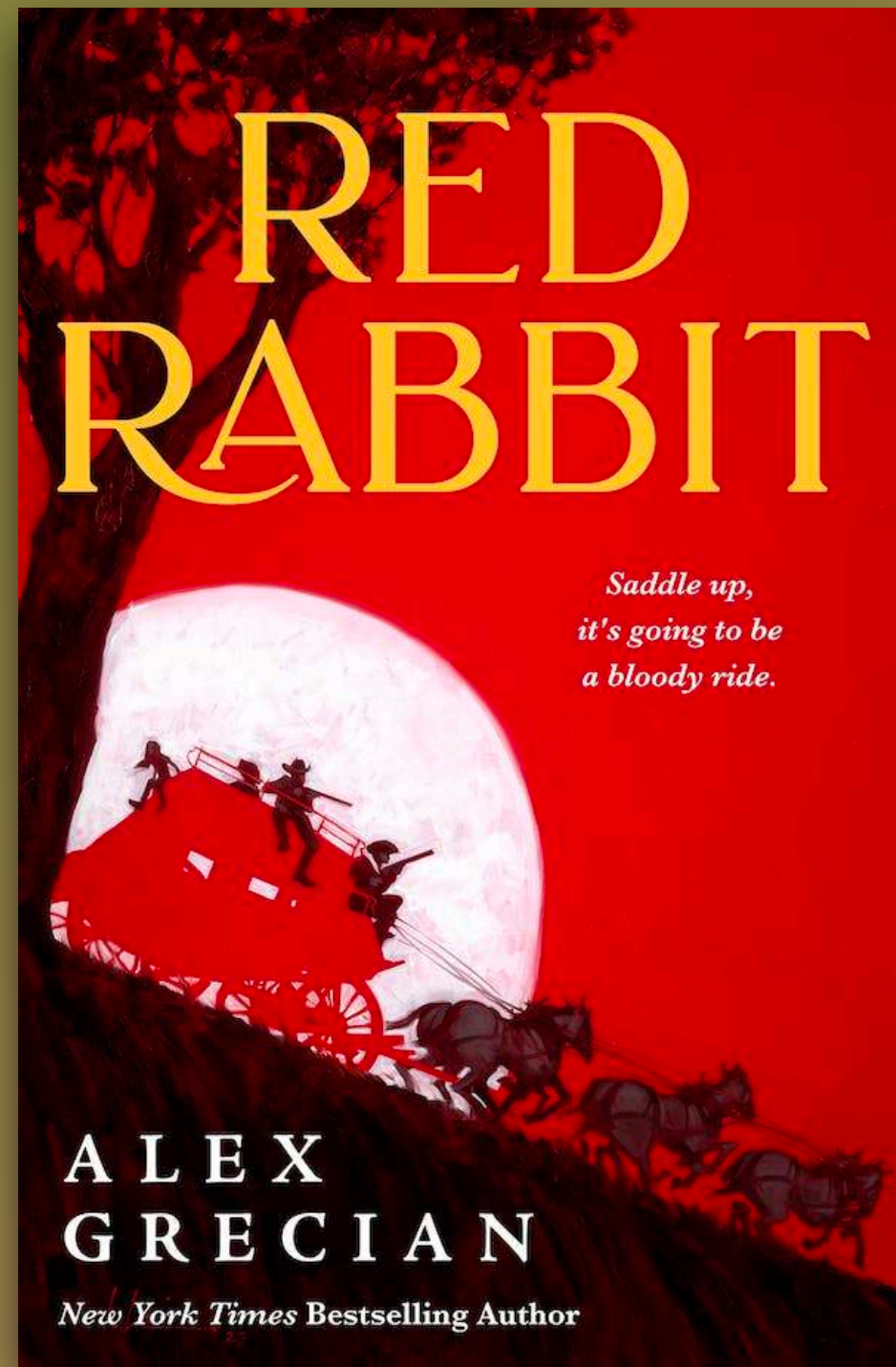

*From bestselling author Alex Grecian comes a folk horror epic about a ragtag posse that must track down a witch through a wild west beset by demons and ghosts  
—and where death is always just around the bend.*

---

**Featured ARC at Bouchercon, Thrillerfest and San Diego Comic Con  
Two Goodreads Sweepstakes, animated jacket release on social media, multi-city tour**

“This is a book I’m going to be pressing into the hands of every reader I know. It’s an epic, sometimes brutal, sometimes tender, but always surprising gallop of a book, populated by characters I found myself caring deeply about. Red Rabbit was impossible to put down.”

—**Kelly Link, author of Pulitzer Prize finalist *Get In Trouble***

“Echoing True Grit, The Good Lord Bird, and any number of classic tales of terror, Alex Grecian’s RED RABBIT is a riotous, Boschian, gun-slinging marvel.”

—**Laird Hunt, author of *In the House in the Dark of the Woods***

“Red Rabbit is a completely immersive experience. With a perfect blend of weirdness, carnage, and unlikely friendships, this is an absolute riot of a book.” —**Tor.com**

Tor Nightfire - September 19, 2023

[historical](#) | [folk horror](#) | [Western](#)

*Editor:* Kelly Lonesome

*Agent:* Seth Fishman

*Material:* Final pages

Sadie Grace is wanted for witchcraft, dead (or alive). And every hired gun in Kansas is out to collect the bounty on her head, including bona fide witch hunter Old Tom and his mysterious, mute ward, Rabbit. On the road to Burden County, they’re joined by two vagabond cowboys with a strong sense of adventure – but no sense of purpose – and a recently widowed schoolteacher with nothing left to lose. As their posse grows, so too does the danger. Racing along the drought-stricken plains in a stolen red stagecoach, they encounter monsters more wicked than witches lurking along the dusty trail. But the crew is determined to get that bounty, or die trying. Written with the devilish cadence of Stephen Graham Jones and the pulse-pounding brutality of Nick Cutter, *Red Rabbit* is a supernatural adventure of luck and misfortune.

**Alex Grecian** is the *New York Times* bestselling author of The Scotland Yard’s Murder Squad series: *The Yard* and its sequels *The Black Country*, *The Devil’s Workshop*, *The Harvest Man*, and *Lost and Gone Forever*; as well as the contemporary thriller *The Saint of Wolves and Butchers*, and the ebook *The Blue Girl*. He has also written multiple award-winning graphic novels, including *Proof*, and *Rasputin*.

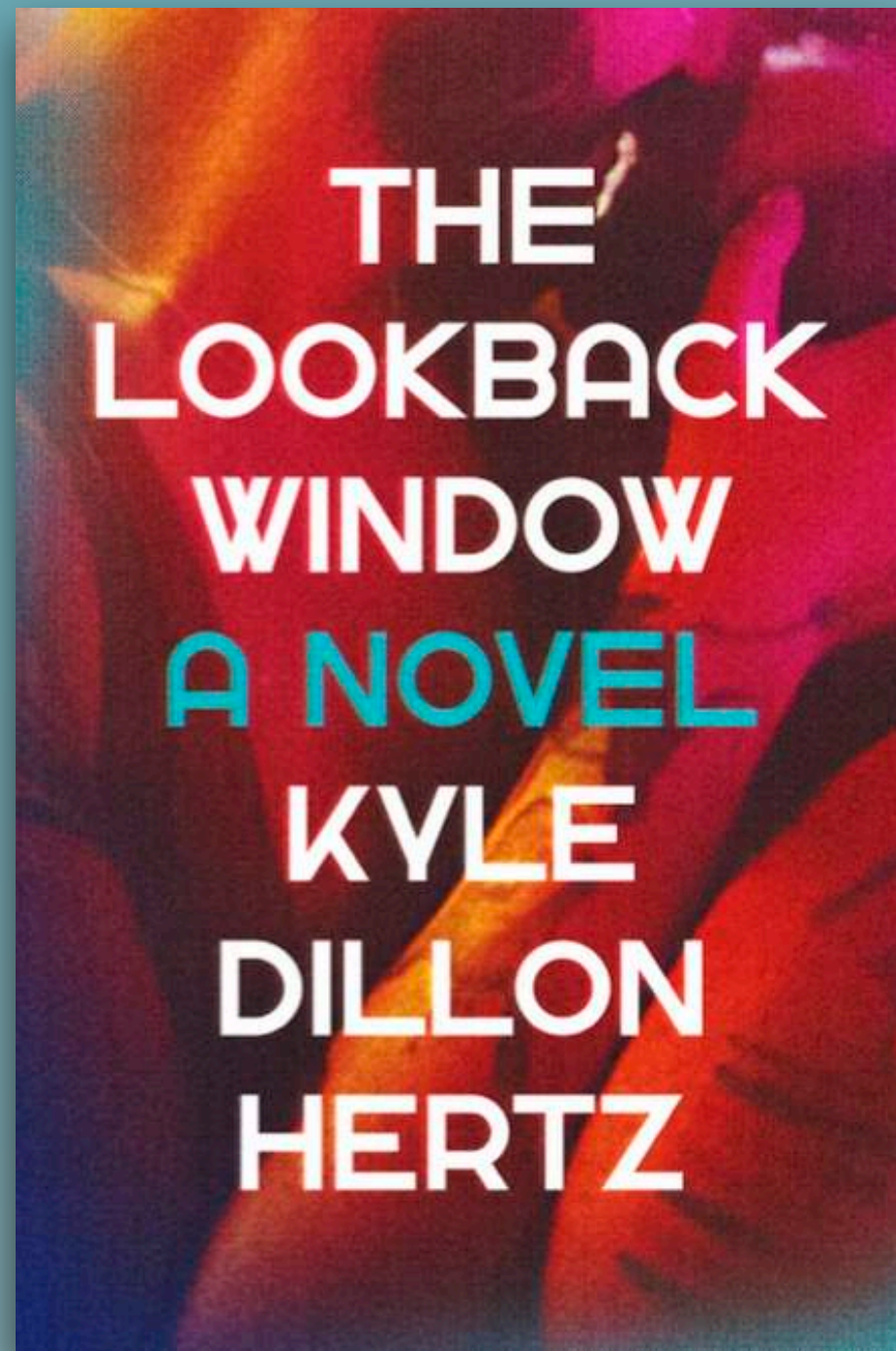

*A fearless debut novel of resilience, transcendence, and the elusive promise of justice*

---

“Hertz has managed to tell a story of queer healing with all the narrative force of a thriller and the searing fury of an indictment.” —***The New York Times Book Review***

“The prose is remarkable, alternating from lush sensuality to unsparing brutality to quick cutting asides. This marks the arrival of a vital new talent.” —***Publishers Weekly***

“*The Lookback Window* is audacious, scandalous, and startling in ways that can only be properly conveyed by a pen as careful and compassionate as Hertz’s. A gutsy, unflinching debut.”  
—**Robert Jones, Jr., author of *The New York Times* bestseller, *The Prophet***

“*The Lookback Window* is a beautiful and heartbreaking tour de force. Hertz writes vengeance as salvation, refusal as a reclamation of humanity.”  
—**Raven Leilani, *New York Times* bestselling author of *Luster***

Simon & Schuster - August 1, 2023

[literary](#) | [lgbtq+](#) | [interiority](#)

**Editor:** Tim O’Connell

**Agent:** Chris Parris-Lamb

**Material:** Final pages

Growing up in suburban New York, Dylan lived through the unfathomable: three years as a victim of sex trafficking at the hands of Vincent, a troubled young man who promised to marry Dylan when he turned eighteen. Years later, long after a police investigation that went nowhere, and after the statute of limitations for the crimes perpetrated against him have run out, the long shadow of Dylan’s trauma still looms over the fragile life in the city he’s managed to build with his fiancé, Moans, who knows little of Dylan’s past. His continued existence depends upon an all-important mantra: *To survive, you live through it, but you never look back.* Then a groundbreaking new law—the Child Victims Act—opens up a new way forward: a one-year window during which Dylan can sue his abusers. But for someone trafficked as a child, does money represent justice? Does his pain have a price? As Dylan is forced to try to make sense of his past, he begins to explore a drug-and sex-fueled world of bathhouses, clubs, and strangers’ apartments, only to emerge, barely alive, with a new clarity of purpose: a righteous determination to gaze, unflinching, upon the brutal men whose faces have haunted him for a decade, and to extract justice on his own terms. By turns harrowing, lyrical, and beautiful, Hertz’s debut offers a startling glimpse at the unraveling of trauma, and the light that peeks, faintly, and often in surprising ways, from the other side of the window.

**Kyle Dillon Hertz** received an MFA in fiction at NYU, where he was the Writer in Public Schools Fellow. His writing has previously appeared in *Freeman’s*. He lives in Brooklyn.

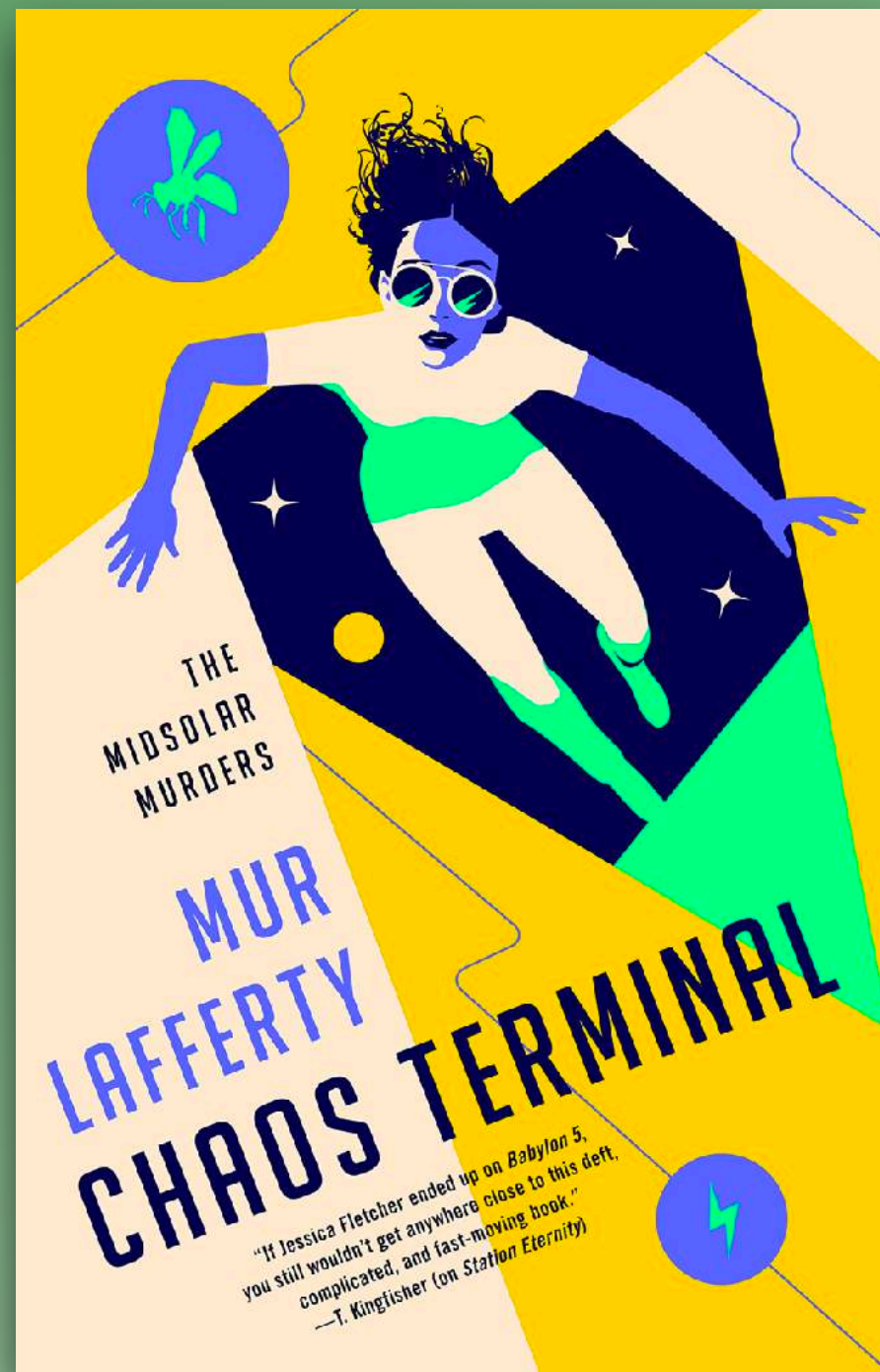

Ace - November 7, 2023

[space opera](#) | [adventure](#) | [science fiction](#)

**Editor:** Anne Sowards

**Agent:** Seth Fishman

**Material:** Final pages

*Mallory Viridian would rather not be an amateur detective, and fled to outer space to avoid it... but when one of the new human arrivals on a space shuttle is murdered, she's back in the game.*

*Book 2 in the Midsolar Murders series by the Hugo Award-winning author*

---

"The follow-up to *Station Eternity* is just as complex and engaging as its predecessor. Lafferty's skill with dialogue and emotional arcs make the story equally character- and action-driven."

—**Library Journal, \*starred review\***

Praise for *Station Eternity*

"What a glorious romp. Murder, sentient space stations, and banter. It had everything I wanted."

—**Mary Robinette Kowal, Hugo and Nebula Award-winning author of *The Calculating Stars***

"The Midsolar Murders series starter offers fascinating world building, a complex mystery, a devious espionage plot, and delightful interactions with a multitude of alien species that fans of science fiction and compelling mysteries will savor while they anticipate the next installment."

—**Booklist, \*starred review\***

Mallory Viridian would rather *not* be an amateur detective, thank you very much. But no matter what she does, people persist in dying around her—and only she seems to be able to solve the crime. After fleeing to an alien space station in hopes that the lack of humans would stop the murders, a serial killer had the nerve to follow her to Station Eternity. (Mallory deduced who the true culprit was that time, too.) Now the law enforcement agent who hounded Mallory on Earth has come to Station Eternity, along with her teenage crush and his sister, Mallory's best friend from high school. Mallory doesn't believe in coincidences, and so she's not at all surprised when someone in the latest shuttle from Earth is murdered. It's the story of her life, after all. Only this time she has more than a killer to deal with. Between her fugitive friends, a new threat arising from the Sundry hivemind, and the alarmingly peculiar behavior of the sentient space station they all call home, even Mallory's deductive abilities are strained. If she can't find out what's going on (and fast), a disaster of intergalactic proportions may occur....

**Mur Lafferty** is an author, podcaster, and editor. She has been nominated for many awards, and even won a few. She lives in Durham, NC with her family.



*An electric contemporary reimagining of the myth of Persephone and Demeter set over the course of one summer on a lush private island, about addiction and sex, family and independence, and who holds the power in a modern underworld.*

---

**Film deal for Rachel Lyon's prior novel, *Self-Portrait with Boy*, with Zoë Kravitz to lead**

"Irresistible and devastating. I devoured *Fruit of the Dead* in a single day. Lyon has spun an utterly absorbing, lush, and terror-laced retelling of an ancient, archetypal tale—a young woman tempted and taken, a mother's feral grief—that is both timeless and crisply contemporary."

—**Melissa Febos, author of *Girlhood***

"Opulent and unsettling, *Fruit of the Dead* explores the island where ancient myth meets the contemporary body. This story is vivid, shocking, evocative. It is both of this time and outside it. It is purely Rachel Lyon. It is wonderful." —**Julia Phillips, author of *Disappearing Earth***

"A brutal, brilliant reimagining of the Persephone/Demeter story, shifted seamlessly into a 21st-century thriller of addiction....*Fruit of the Dead* is a scathing and stunning indictment of patriarchal mythology."

—**Maria Dahvana Headley, author of *The Mere Wife***

Camp counselor Cory Ansel, eighteen and aimless, afraid to face her high-strung single mother in New York, is no longer sure where home is when the father of one of her campers offers an alternative. The CEO of a Fortune 500 pharmaceutical company, Rolo Picazo is middle-aged, divorced, magnetic, and intoxicated by Cory. When Rolo proffers a childcare job (and an NDA), Cory allows herself to be ferried to his private island. Plied with luxury and opiates manufactured by his company, she continues to tell herself she's in charge. Her mother, Emer, head of a teetering agricultural NGO, senses otherwise. With her daughter seemingly vanished, Emer crosses land and sea to heed a cry for help she alone is convinced she hears. Alternating between the two women's perspectives, *Fruit of the Dead* incorporates mythic inspiration with a light touch and devastating precision, resulting in a tale that explores love, control, and obliteration. Lyon's reinvention of Persephone and Demeter's story makes for a haunting and ecstatic novel that vibrates with lush abandon.

**Rachel Lyon's** debut novel *Self-Portrait with Boy* was a finalist for the Center for Fiction's First Novel Prize. An editor emerita for Epiphany, she has taught creative writing at the Sackett Street Writers Workshop, Bennington College, and other institutions. A native of Brooklyn, New York, Rachel lives in western Massachusetts with her husband and two young children.

Scribner - March 5, 2024

[coming of age](#) | [greek mythology](#) | [mother/daughter relationship](#)

**Rights sold:**

**Scribner (UK & BC)**

*Editor:* Kara Watson

*Agent:* Meredith Kaffel Simonoff

*Material:* 3rd pass pages

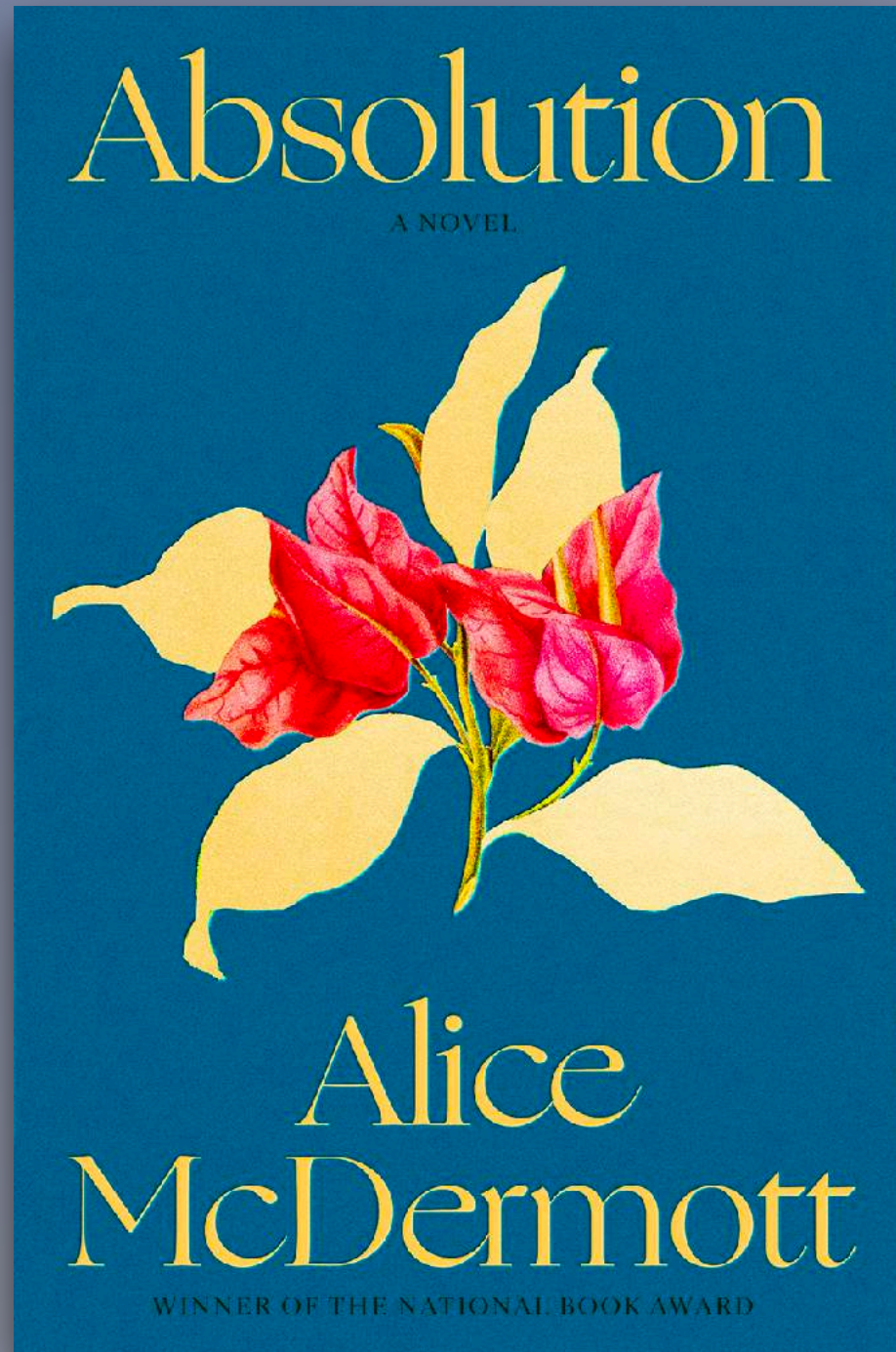

Farrar, Straus & Giroux - October 31, 2023

[literary](#) | [historical](#) | [Vietnam War](#)

**Rights sold:**

**Bloomsbury (UK & BC),  
La Table Ronde (France)**

*Editor:* Jonathan Galassi

*Agent:* Sarah Burnes

*Material:* Final pages

*A riveting account of women's lives on the margins of the Vietnam War,  
from the renowned winner of the National Book Award*

---

"Alice McDermott has always been one of our greatest writers but here she exceeds every expectation. *Absolution* is one of the finest contemporary novels I've read. It is a moral masterpiece." —**Ann Patchett, author of *The Dutch House***

"For more than 40 years, McDermott's deep understanding of human nature and wizardry in creating characters has been the seedbed of one bestselling, award-winning novel after another. Now she has outdone herself with an exquisitely conceived and executed novel that explores her signature topic, moral obligation, against the backdrop of the fraught time preceding the Vietnam War. This transporting, piercing, profound novel is McDermott's masterpiece."  
—**Kirkus, *\*starred review\****

"Alice McDermott delivers another elegantly written, immaculately conceived novel that immerses the reader in the contradictions and moral ambiguities of the human heart. What a splendid, compelling book this is." —**Tim O'Brien, author of *The Things They Carried***

In Saigon in 1963, two young American wives form a wary alliance. Tricia is a starry-eyed newlywed, married to a rising oil engineer "on loan" to US Navy Intelligence. Charlene is a practiced corporate spouse and mother of three, a talented hostess and determined altruist, on a mission to relieve the "wretchedness" she sees all around her. When Tricia miscarries, Charlene sweeps her into a cabal of well-dressed do-gooder wives. Armed with baskets filled with candy and toys, they descend on hospitals, orphanages, and a leper colony on the coast, determined to relieve suffering, no matter the cost. Sixty years later, Charlene's daughter reaches out to Tricia, now widowed and living in Washington. As the two relive their shared experience in Saigon, they are forced to come to terms with the ways their own lives have been shaped and stunted by Charlene's pursuit of "inconsequential good." With a narrative impact that recalls Graham Greene's *The Quiet American*, Alice McDermott confronts the unresolved mysteries and ironies of America's tragic interference in Southeast Asia.

**Alice McDermott** is the author of several novels, including *The Ninth Hour*; *Someone*; *After This*; *Child of My Heart*; *Charming Billy*, winner of the 1998 National Book Award; and *At Weddings and Wakes*—all published by FSG. *That Night*, *At Weddings and Wakes*, and *After This* were all finalists for the Pulitzer Prize. Her stories and essays have appeared in *The New York Times*, *The Washington Post*, *The New Yorker*, *Harper's Magazine*, and elsewhere.

*Scotiabank Giller Prize winner Sean Michaels's moving, innovative and deeply felt novel about an aging poet who agrees to collaborate with a Big Tech company's poetry AI, named Charlotte*

---

"A tender and moving character portrait full of sharp scenes and memorable observations. While the novel might have a timely premise, it's a jumping-off point for timeless meditations on art, family, connection and the meaning of a life." — **The New York Times**

"A timely work reminiscent of Richard Powers' *Galatea 2.2* (1995), Michaels' tale shows how AI can, paradoxically, stymie creation through its limitlessness and need for human guidance. This is also a compelling portrait of a tricorne-wearing poet famously dedicated to her craft." — **Booklist**

"Michaels merges modernist poetry with contemporary technology in this inventive outing . . . [*Do You Remember Being Born?* asks] probing and humane questions about what it means to be an artist." — **Publishers Weekly**

"Could a novel be any timelier than *Do You Remember Being Born?* Wonderfully written, it makes you think, on every single page, of where it is we're going as a species." — **Douglas Copeland, author of *Worst. Person. Ever.***



Astra House - September 5, 2023

[literary fiction](#) | [AI](#) | [poetry](#)

**Rights sold:**

**Random House (Canada), Antoine Tanguay (French Canadian), Moonhak Soochup (Korea)**

*Editor:* Deborah Ghim

*Agent:* Meredith Kaffel Simonoff

*Material:* Final pages

Marian Ffarmer is a world-renowned poet but only now, at 75 years old, is she beginning to believe in the security of her successes. Unfortunately, a poet's accomplishments don't necessarily translate to capital, and as her adult son struggles to buy his first home, her confidence in her choices begins to fray. Marian's pristine life of mind—for which she's sacrificed nearly all personal relationships, from romance to friendship to motherhood—has come at a cost. Then comes a cryptic invitation from the Tech Company to come to California, and write with a machine. The lucrative offer—for Marian to co-author a poem in a 'historic partnership' with their cutting-edge poetry bot, named Charlotte—chafes at everything she believes about artmaking, yet, it's a second chance she can't resist. And so to California she goes for an encounter that will unsettle her life, her work and even her understanding of kinship. Both a love letter to and interrogation of the nature of language, art, labor, capital, family, and community.

**Sean Michaels** is a novelist, short story writer and critic. He is the founder of pioneering music blog *Said the Gramophone*. His debut novel, *Us Conductors*, received the Scotiabank Giller Prize. His second novel, *The Wagers*, appeared in 2019.

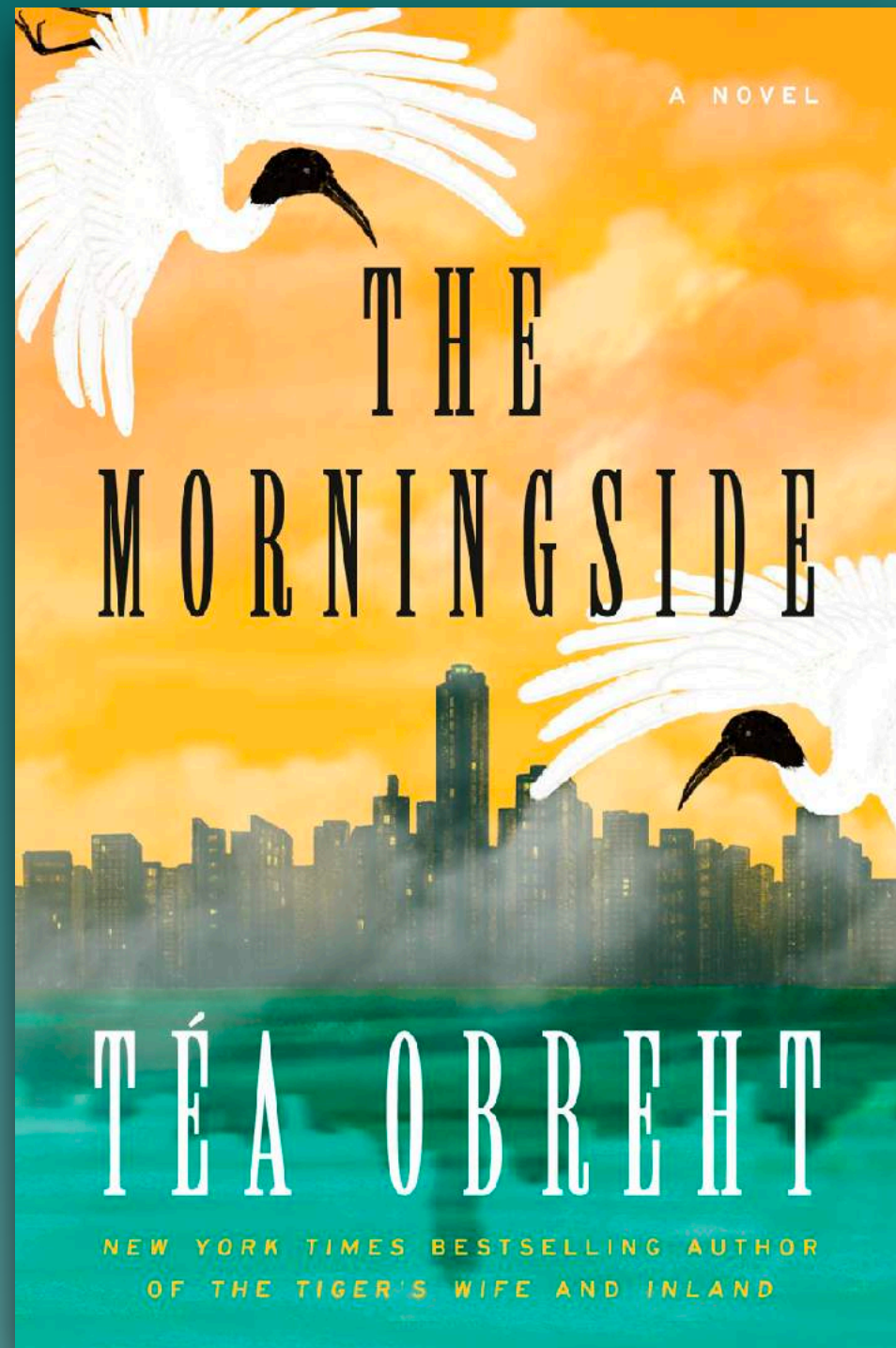

Random House - March 19, 2024

[literary fiction](#) | [magical realism](#) | [family](#)

**Rights sold:**

**Weidenfeld & Nicolson (UK & BC),  
Rowohlt Berlin (Germany)**

*Editor:* Andrea Walker

*Agent:* Seth Fishman

*Material:* 1st pass pages

*From the critically beloved, New York Times bestselling author of *The Tiger's Wife* and *Inland*, a magical novel of mothers and daughters, displacement and belonging, and myths old and new.*

---

Praise for Téa Obreht

"[Obreht] has a talent for subtle plotting that eludes most writers twice her age, and her descriptive powers suggest a kind of channeled genius."—**The Wall Street Journal**

"Obreht is the kind of writer who can forever change the way you think about a thing, just through her powers of description."—**Elizabeth McCracken, O: The Oprah Magazine**

After being expelled from their ancestral home in a not-so-distant-future, Silvia and her mother finally settle at The Morningside, a crumbling luxury tower in a place called Island City where Silvia's aunt Ena serves as the superintendent. Silvia feels unmoored in her new life because her mother has been so secretive about their past, and because the once-vibrant city she lives in is now half-underwater. Silvia knows almost nothing about the place where she was born, nor does she fully understand why she and her mother had to leave. But in Ena there is an opening: a person willing to give the young girl glimpses into the folktales of her demolished homeland. Enchanted by Ena's stories, Silvia begins seeing the world with magical possibilities and becomes obsessed with the mysterious older woman who lives in the penthouse of the Morningside. Bezi Duras is an enigma to everyone in the building: She has her own elevator entrance and leaves only to go out at night and walk her three massive hounds, often not returning until the early morning. Silvia's mission to unravel the truth about this woman's life, and her own haunted past, may end up costing her everything. Startling, inventive, and profoundly moving, *The Morningside* is a novel about the stories we tell—and the stories we refuse to tell—to make sense of where we came from and who we hope we might become.

**Téa Obreht** is the internationally bestselling author of *The Tiger's Wife*, which won the 2011 Orange Prize for Fiction and was a finalist for the National Book Award. Her second novel, *Inland*, was an instant bestseller, won the Southwest Book Award, and was a finalist for the Dylan Thomas Prize. Her work has appeared in *The Best American Short Stories*, *The New Yorker*, *The Atlantic*, *Harper's*, and *Zoetrope: All-Story*, among many others. Originally from the former Yugoslavia, she now resides in Wyoming.

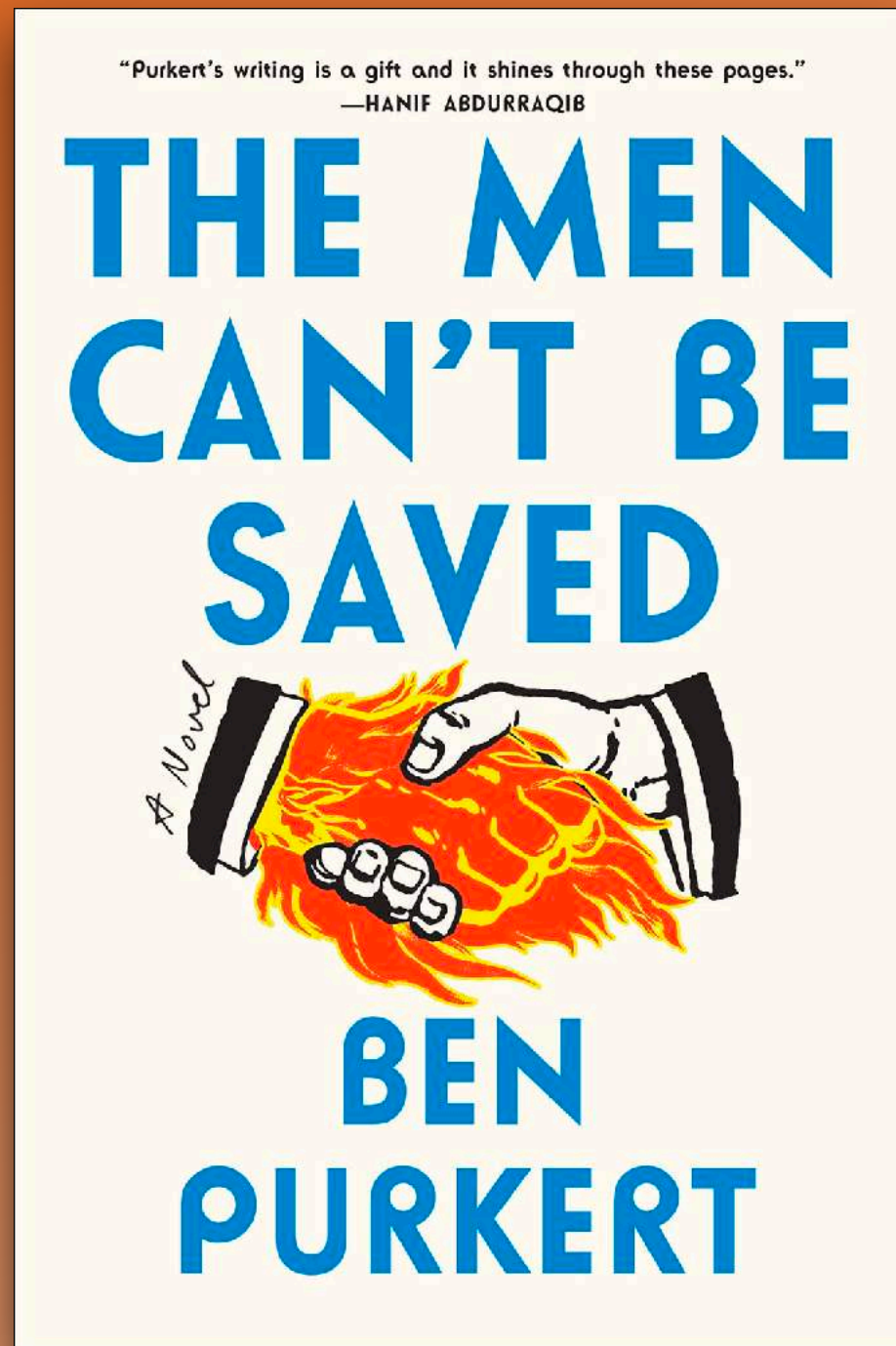

## *A rollicking debut novel that tackles a haunting question: What do our jobs do to our souls?*

---

"[Purkert's] forebears are the likes of Teddy Wayne, Joshua Ferris, Sam Lipsyte and Gary Shteyngart, all of whom have written brash and funny satires of family, workplaces and masculinity gone off the rails. That crowd of Gen X writers were in turn inspired by the schlemiel-like heroes of Saul Bellow and Philip Roth....[Purkert is] a sharply funny observer of male foibles, 20-something angst, and the modern workplace."—**Washington Post**

"A 21st-Century *Catcher in the Rye* that examines the 'genius' worship and toxic masculinity still dominating the advertising world today. [A] muscular novel . . . startlingly funny thanks to an unforgettable narrator [with a] Jupiter-sized ego."—**Esquire**

"The flash and sizzle of [Purkert's] wit really deliver."—**Kirkus Reviews**

"I laughed more times than I can count. A phenomenal debut by one of my favorite writers."  
—**Clint Smith, #1 New York Times bestselling author of *How The Word Is Passed***

Overlook Press - August 1, 2023

[literary](#) | [humor](#) | [society](#)

**Editor:** Zack Knoll

**Agent:** Alia Hanna Habib

**Material:** Final pages

Seth is a junior copywriter whose latest tagline just went viral. But this professional triumph won't fix his personal life—his coworker crush won't be seen with him, and his only comfort is in pills. When his company lets him go, he can't let go of his job. Thankfully, one former colleague can't let him go either: Robert "Moon" McCloone, a sleazy on-the-rise exec better suited to a dorm room than a boardroom. When Seth gets taken in by an overeager Orthodox rabbi, he tries to forget Moon and replace his professional ambitions with higher purpose—but is he only digging himself deeper? In his debut novel, Purkert incisively explores two kinds of toxic masculinity: the guys who see no problem with their bad behavior, and those who don't see it as bad at all. Brimming with wit, irreverence, and soul-searching, *The Men Can't Be Saved* is a startlingly original examination of work, religion, sex, drugs, and ourselves.

**Ben Purkert** is the author of the poetry collection *For the Love of Endings*. His work appears in *The New Yorker*, *the Nation*, and *the Kenyon Review*, among others. He is the founder of Back Draft, a *Guernica* interview series focused on revision and the creative process. He holds degrees from Harvard and New York University, and he currently teaches at Rutgers.

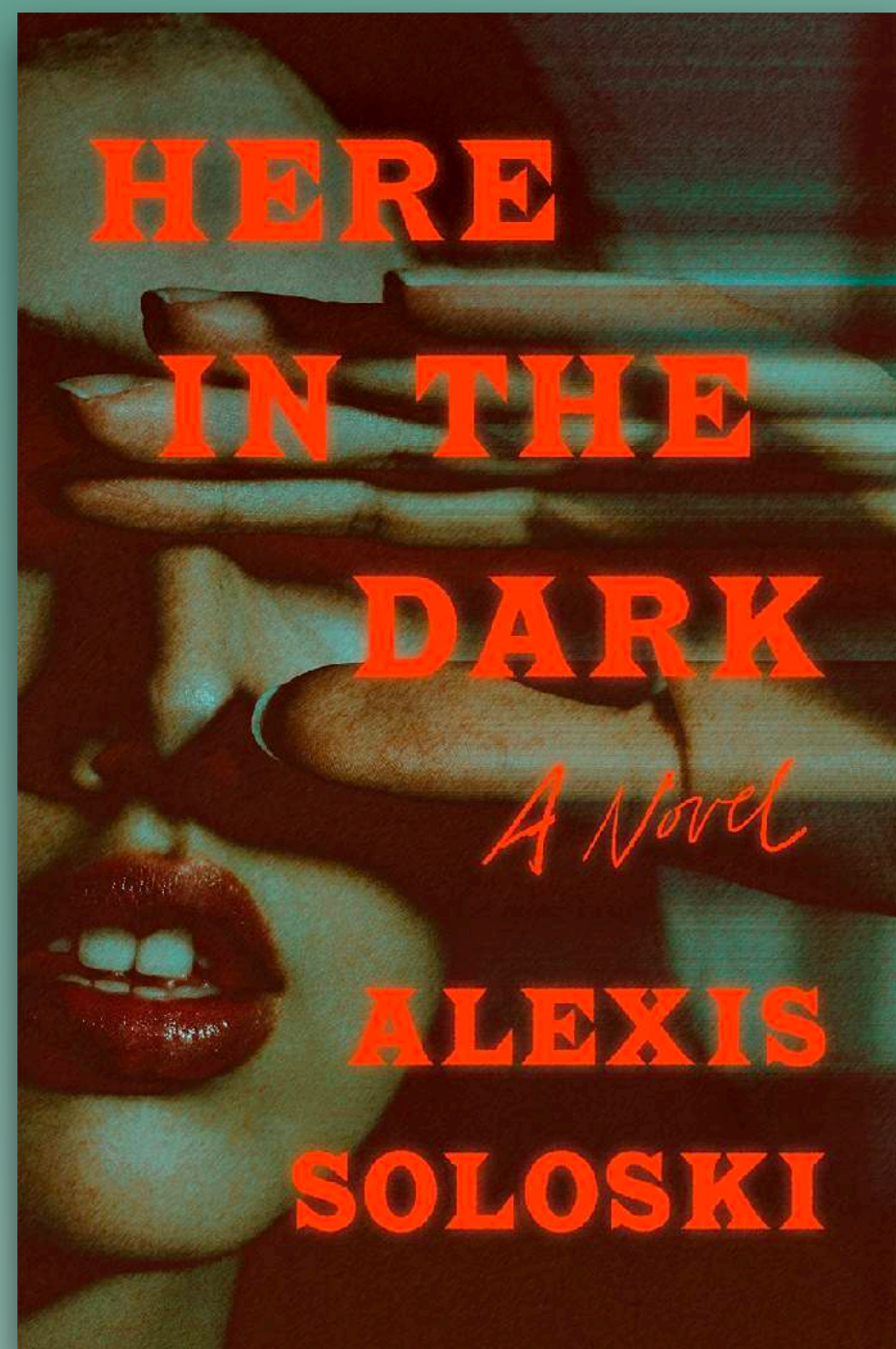

*A young theater critic is drawn into a dangerous game that blurs the lines between reality and performance. A gripping debut from the New York Times theater critic.*

---

"From its very first page to its final revelation, *Here in the Dark* will possess you with a mix of acerbic wit and Highsmithian invention. You'll be thrilled by the ways Soloski takes the novel of suspense and turns it into a meditation on seeing and being seen, knowing and being known, judging and being judged." —**Isaac Butler, author of *The Method: How the Twentieth Century Learned to Act***

"A moody, taut dose of noir, *Here in the Dark* is a poised, daring debut—the kind of novel I relish and can't get out of my head, evoking the work of icons like Megan Abbott and Margaret Millar in its hypnotic prose and mesmerizing characters. Readers will not forget Vivian Parry—and they won't want to." —**Alex Segura, bestselling author of *Secret Identity***

"Hitchcock meets a slippery metatheatre of power, performance, desire, and escape. This is a novel - and a protagonist - who moves with a precious velocity, constantly choosing the most dangerous move and bringing us careening after." —**Jen Silverman, author of *We Play Ourselves***

Vivian Parry likes the dark. A former actress, she now works as the junior theater critic at a major Manhattan magazine. Her nights are spent beyond the lights, in a reserved seat, giving herself over to the shows she loves. By day, she savages them, with words sharper than a knife. Angling for a promotion, Vivian reluctantly agrees to give an interview in which the conversation, with a stranger who seems to know her work, reveals secrets she thought she had long since buried. When her interviewer disappears soon thereafter, she learns from his devastated fiancé that Vivian was the last person to have seen him alive. When the police refuse to investigate, Vivian assumes the role of amateur detective. . As she nears the final act of this investigative ruse, she finds that the boundaries between theater and the real world are more tenuous and more dangerous than even she could have believed. Gripping, propulsive, and shot through with menace and dark glamour, *Here in the Dark* takes us behind the scenes of New York theater, lifting the curtain on the lies we tell ourselves and each other.

**Alexis Soloski** is a prize-winning *New York Times* theater critic and a former lead theater critic at the *Village Voice*. She has taught at Barnard College and at Columbia University, where she earned her PhD in Theater. She lives in Brooklyn with her family.

Flatiron - December 5, 2023

[psychological suspense](#) | [New York City theater](#)

**Rights sold:**  
**Raven/Bloomsbury (UK & BC),**  
**Eichborn (Germany)**

*Editor:* Megan Lynch

*Agent:* Sarah Burnes

*Material:* Final pages

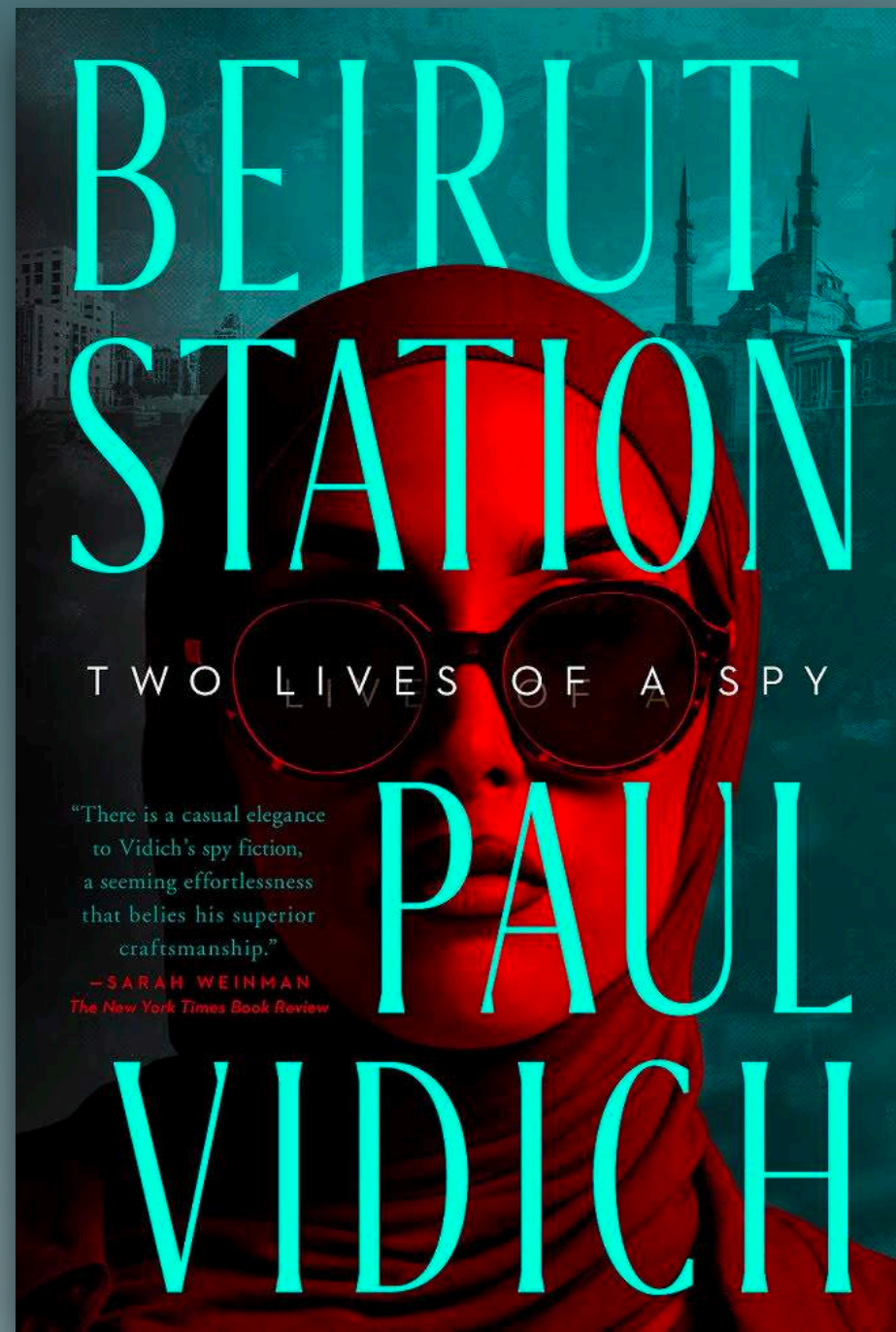

Pegasus Books - October 3, 2023

[international](#) | [thriller](#) | [espionage](#)

**Rights sold:**

**No Exit Press (UK & BC)**

*Editor:* Victoria Wenzel

*Agent:* Will Roberts

*Material:* Final pages

*Beirut Station follows a young female CIA officer whose joint mission to assassinate a high-level Hezbollah terrorist reveals a dark truth that puts her life at risk.*

---

“This taut, nuanced spy thriller centered on Lebanese American CIA agent Analise Assad further establishes Vidich as a new master of the genre. Vidich ably describes daily life in a war-torn setting and convincingly highlights the dangers Analise faces as a woman in her position. He brings the action to a satisfying conclusion. Fans of Eric Ambler, Graham Greene, and John le Carré will be eager for more.”—***Publishers Weekly***

Previous praise:

“There is a casual elegance to Vidich’s spy fiction, a seeming effortlessness that belies his superior craftsmanship.” —***New York Times Editor’s Choice***

“Cold War spy fiction in the grand tradition.” —**Joseph Kanon, *New York Times* bestselling author**

Lebanon, 2006. The Israel-Hezbollah war is tearing Beirut apart. In the midst of this turmoil, the CIA and Mossad are targeting a reclusive Hezbollah terrorist, Najib Qassem. Najib is believed to be planning the assassination of Secretary of State Condoleezza Rice, who is coming to Beirut in ten days to broker a cease-fire. The spy agencies are running out of time to eliminate the threat so they turn to a young Lebanese-American CIA agent. Analise comes up with the perfect plan: she has befriended Qassem's grandson as his English tutor, and will use this friendship to locate the terrorist and take him out. As the plan is put into action, Analise begins to suspect that Mossad has a motive of its own: exploiting the war's chaos to eliminate a generation of Lebanese political leaders. She alerts the agency but their response is for her to drop it. Analise is now the target and there is no one she can trust: not the CIA, not Mossad, and not the Lebanese government. And the one person she might have to trust—a reporter for the *New York Times*—might not be who he says he is...

**Paul Vidich** is the acclaimed author of *The Matchmaker*, *The Mercenary*, *The Coldest Warrior*, *An Honorable Man*, and *The Good Assassin*. His fiction and nonfiction have appeared in the *Wall Street Journal*, *LitHub*, *CrimeReads*, *Fugue*, *The Nation*, *Narrative Magazine*, and *Wordriot*. He lives in New York City.

*Better to die sharp in war than rust through a time of peace.*  
*The latest novel by a rising star of character-driven Sci Fi and Fantasy*

---

**70,000 copies sold of the self-published edition to date**

“Fantasy and martial arts aficionados alike should enjoy this emotionally supercharged novel about love and loss, which pierces readers’ hearts with the precision of a samurai’s razor-sharp blade.”

—**Blue Ink, \*starred review\***

“This book pleased me on all levels and I give it my highest recommendation.”

—**Mark Lawrence, author of *The Broken Empire* trilogy**

“Avatar the Last Airbender meets Robin Hobb... I loved reading this book cover to cover.”

—**Rob J. Hayes, author of series *The First Earth Saga, The Mortal Techniques, and The War Eternal***

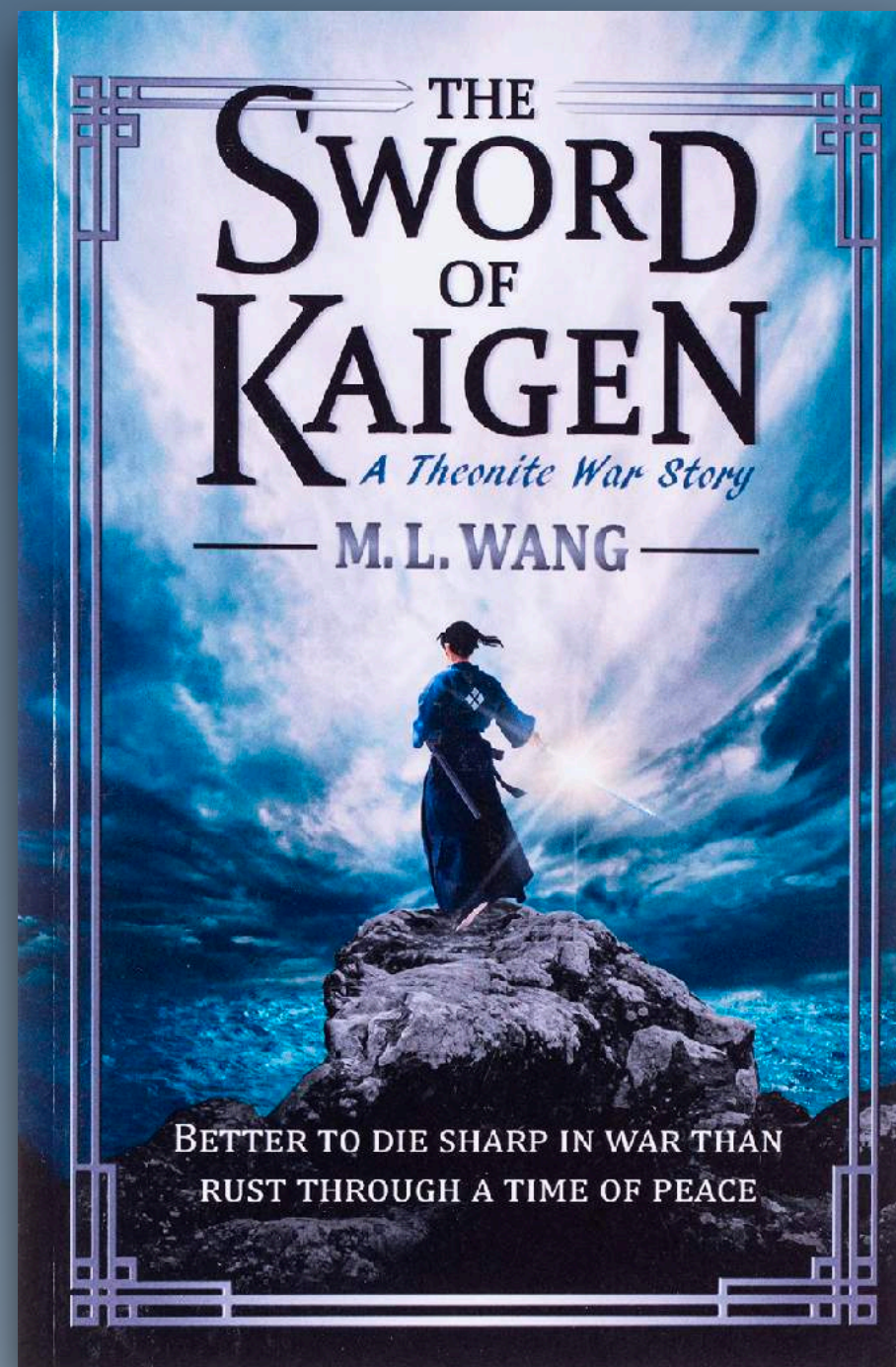

*Self published* - February 13, 2019

[epic](#) | [fantasy](#) | [mythology](#)

**Rights sold:**

**Mondadori (Italy),**

**Wydawnictwo Vesper/In Rock  
(Poland)**

*Agent:* Seth Fishman

*Material:* Final pages

On a mountainside at the edge of the Kaigenese Empire live the most powerful warriors in the world, superhumans capable of raising the sea and wielding blades of ice. For hundreds of years, the fighters of the Kusanagi Peninsula have held the Empire’s enemies at bay, earning their frozen spit of land the name ‘The Sword of Kaigen.’ Born into Kusanagi’s legendary Matsuda family, fourteen-year-old Mamoru has always known his purpose: to master his family’s fighting techniques and defend his homeland. But when an outsider arrives and pulls back the curtain on Kaigen’s alleged age of peace, Mamoru realizes that he might not have much time to become the fighter he was bred to be and the empire he was bred to defend may stand on a foundation of lies. Misaaki told herself that she left the passions of her youth behind when she married into the Matsuda house. Determined to be a good housewife and mother, she hid away her sword, along with everything from her days as a fighter in a faraway country. But with her growing son asking questions about the outside world, the threat of an impending invasion looming across the sea, and her frigid husband grating on her nerves, Misaaki finds the fighter in her clawing its way back to the surface. When war reaches the peninsula, will the Matsudas have the strength to defend their empire or will they tear each other apart before true enemies reach their shores?

**M. L. Wang** is an author, martial artist, and weird recluse currently hiding somewhere in Wisconsin with her maroon-bellied parakeet, Sulu. Her books include *Blood Over Bright Haven*, *The Sword of Kaigen*, the Theonite Series, and *The Volta Academy Chronicles* (published under Maya Lin Wang).

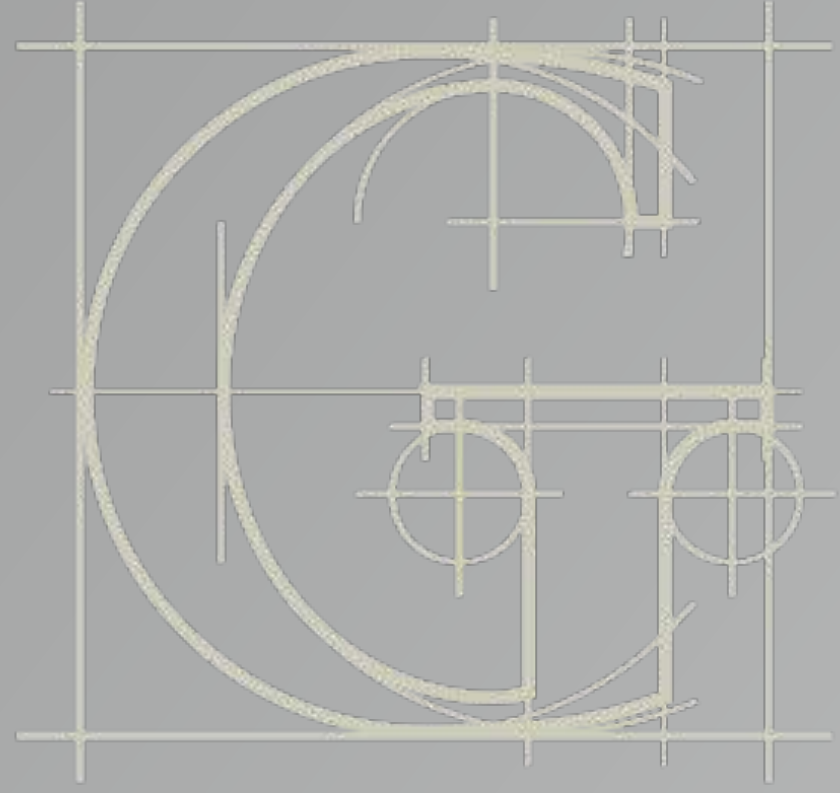

*the*  
**gernert**  
*company*

***NON-FICTION***

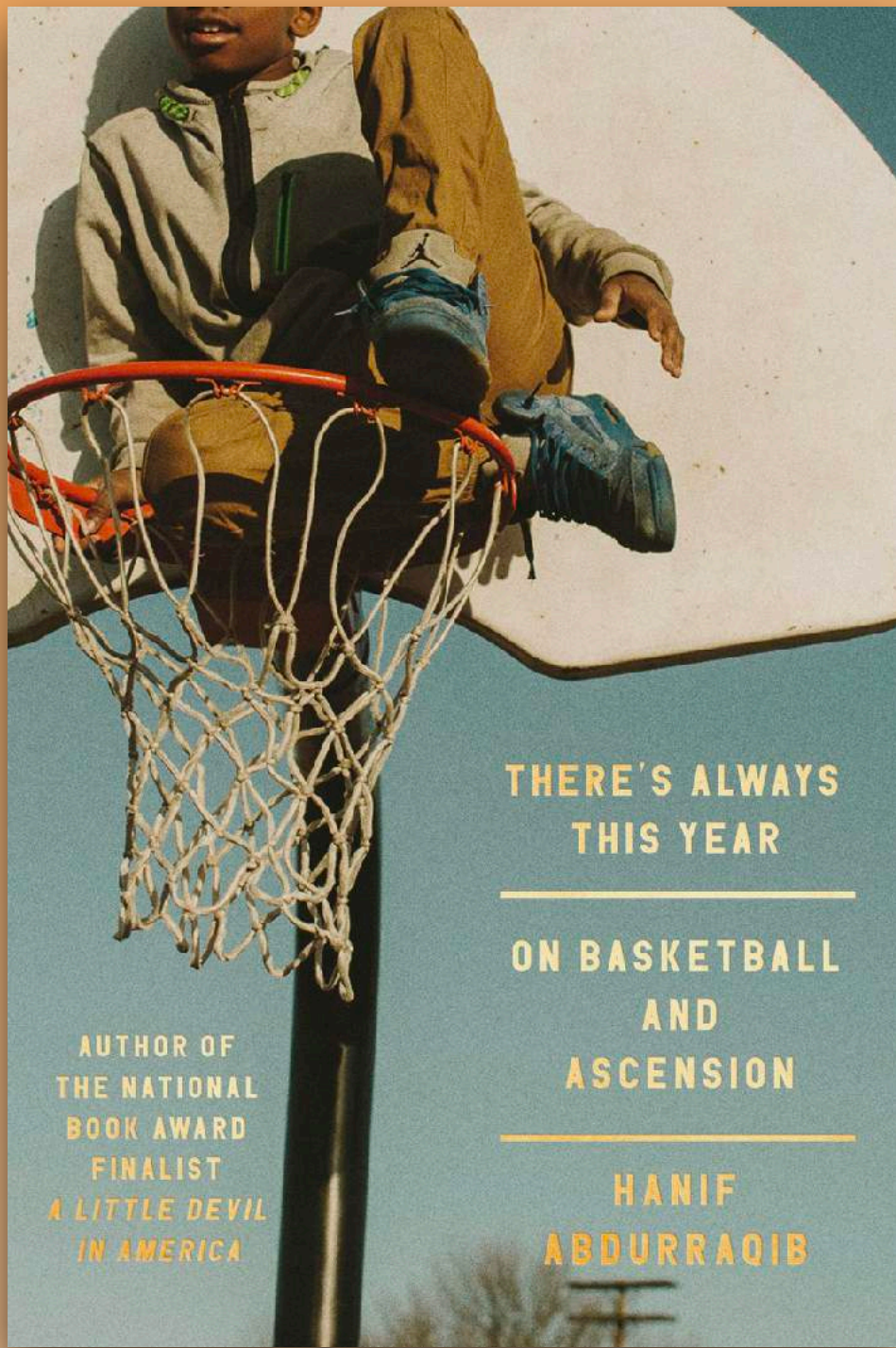

Random House - March 26, 2024

[basketball](#) | [lyrical history](#) | [narrative](#)

**Option publishers: Martin Fontes (Brazil), Black Coffee (Italy), Liburuak (Spain)**

*Editor:* Ben Greenberg  
*Agent:* Alia Hanna Habib  
*Material:* 1st pass pages

*A poignant, personal reflection on basketball, talent and allegiance, and of course, LeBron James—from the author of the National Book Award finalist A Little Devil in America*

---

Praise for Hanif Abdurraqib:

“To call [Hanif] Abdurraqib anything less than one of the best writers working in America, and to call this book anything less than a masterpiece, would be doing him, and literature as a whole, a disservice.”—**Minneapolis Star Tribune on A Little Devil in America**

“Hanif is one of the most exciting writers of his generation.”—**Los Angeles Review of Books**

“Abdurraqib is one of the most brilliant writers I’ve ever read”—**Jacqueline Woodson**

While Hanif Abdurraqib is an acclaimed author, a gifted poet, and one of our culture’s most insightful critics, he is most of all, at heart, an Ohioan. Growing up in Columbus in the 1990s, Abdurraqib witnessed a golden era of basketball, one in which legends like LeBron were forged, and countless others weren’t. His lifelong love of the game leads Abdurraqib into a lyrical, historical, and emotionally rich exploration of what it means to make it, who we think deserves success, the tensions between excellence and expectation, and the very notion of role models, all of which he expertly weaves together with memoir. “Here is where I would like to tell you about the form on my father’s jumpshot,” Abdurraqib writes. “The truth, though, is that I saw my father shoot a basketball only one time.”

*There’s Always This Year* is a classic Abdurraqib triumph, brimming with joy, pain, solidarity, comfort, outrage, and hope. It’s about basketball in the way *They Can’t Kill Us Until They Kill Us* is about music and *A Little Devil in America* is about history—no matter the subject, Abdurraqib’s exquisite writing is always poetry, always profound, and always a clarion call to radically reimagine how we think about our culture, our country, and ourselves.

**Hanif Abdurraqib** is a poet, essayist, and cultural critic from Columbus, Ohio. He is also a recipient of the MacArthur Foundation “Genius” grant. Abdurraqib’s recent book, *A Little Devil in America*, was the winner of the Carnegie Medal and the Gordon Burns Prize and a finalist for the National Book Award. He is a graduate of Beechcroft High School.

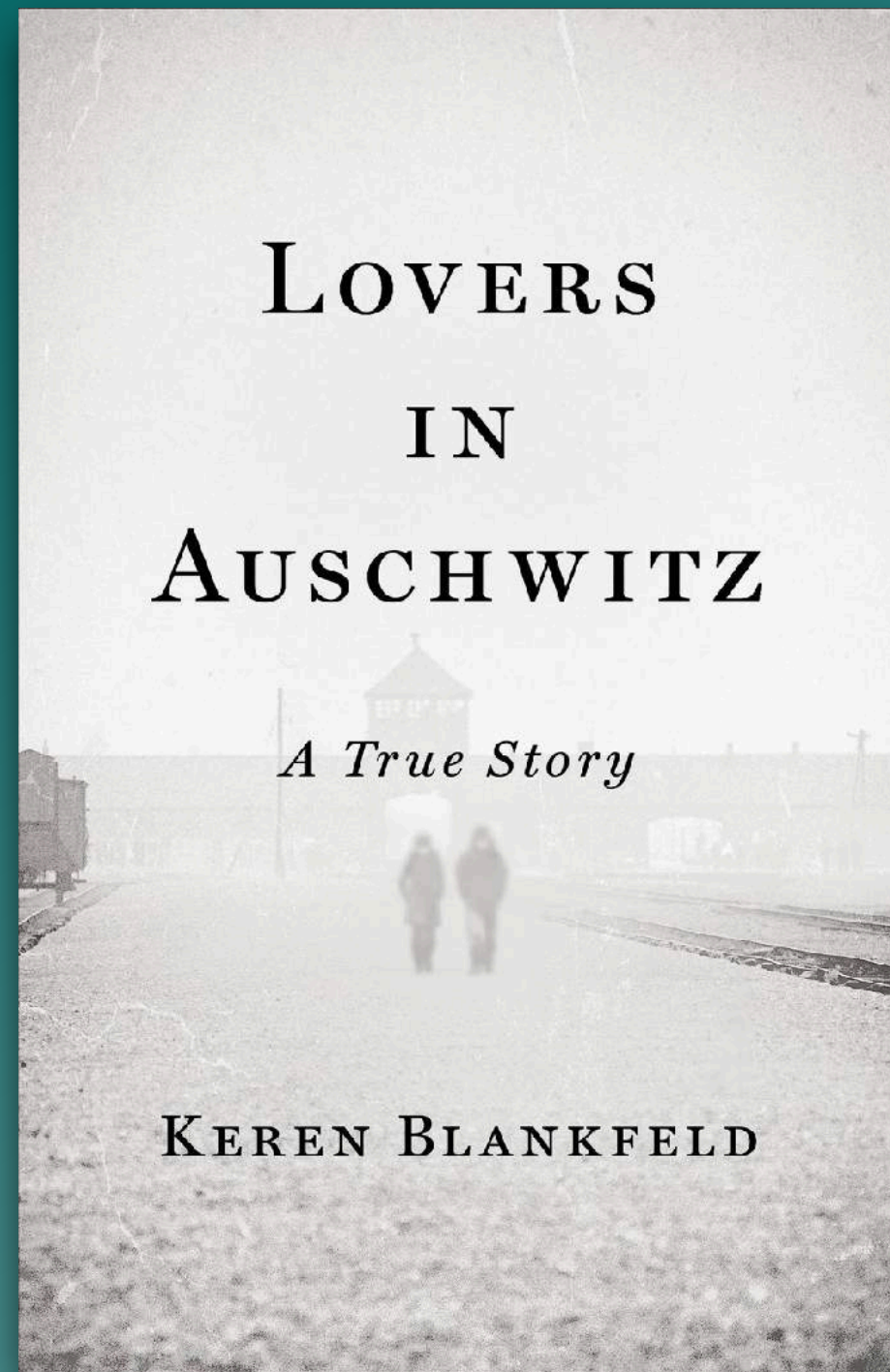

*The incredible true story of two Holocaust survivors who fell in love in Auschwitz, only to be separated upon liberation and lead remarkable lives apart following the war  
—and then find each other again more than 70 years later.*

---

**Film rights under option  
9 Foreign deals to date**

Zippi Spitzer and David Wisnia were captivated by each other from the moment they first exchanged glances across the work floor. It was the beginning of a love story that could have happened anywhere. Except for one difference: this romance was unfolding in history's most notorious death camp, between two young prisoners whose budding intimacy risked dooming them if they were caught. Incredibly, David and Zippi survived for years beneath the ash-choked skies of Auschwitz. Under the protection of their fellow inmates, their romance grew and deepened, even as their brushes with death mounted and David's luck in particular seemed close to running out. As the war's end finally approached and the time came for them to leave the camp, David and Zippi made plans to meet again. But neither of them could imagine how long their reunion would take or how many lives they would live in the interim. They had no inkling, either, of the betrayals that would await them along the way. But David did suspect that Zippi harbored a secret—one that could explain the mystery of his survival all those years ago.

An unbelievable tale of romance, sacrifice, loss, and resilience, *Lovers in Auschwitz* is a saga of two young people who found themselves trapped inside a waking nightmare of the Nazis' creation, yet who nevertheless discovered a love that sustained them through history's darkest hour.

**Keren Blankfeld** is a long-form journalist with a special interest in investigative narrative nonfiction. A former staff writer for *Forbes Magazine*, her stories have appeared in the *New York Times*, *Forbes*, *Reuters*, *The Toronto Star*, and others. She teaches reporting and writing at the Columbia Graduate School of Journalism and has also taught at the New York University's Graduate School. She has been a guest on CNN, BBC World News, and E! Entertainment. In 2013, Keren served as a creative executive at New Regency Productions, where she worked with screenwriters and playwrights to develop material for movies and TV shows. She holds a B.A. in International Relations and English from Tufts University and an M.S. in Journalism from Columbia University. She now lives in New York with her husband and two sons.

Little, Brown - January 23, 2024

[history](#) | [Holocaust](#) | [love story](#)

**Rights sold: Ebury (UK & BC),  
Meulenhoff Boekerij (Netherlands),  
Like (Finland), Albin Michel (France),  
Piemme (Italy), Azbooka-Atticus  
(Russia), Ikar (Slovakia), Plaza & Janes  
(Spanish), Laboratory (Ukraine)**

*Editor:* Alex Littlefield

*Agent:* Erika Storella

*Material:* 1st pass pages

**THE TIME OF AI:  
How Generative AI is  
Changing Culture, Work,  
Politics and Time**

**Kate Crawford**



Farrar, Straus & Giroux - 2026

[history](#) | [artificial intelligence](#) | [culture](#)

*Editor:* Eric Chinski

*Agent:* Chris Parris-Lamb

*Material:* Proposal

*A riveting, intellectual journey through the history of artificial intelligence  
and how it has shaped culture and the workplace*

---

Praise for Kate Crawford and *Atlas of AI*:

"This study argues that artificial intelligence is neither artificial nor particularly intelligent. . . . A fascinating history of the data on which machine-learning systems are trained." —**The New Yorker**

"Crawford argues passionately that while AI is presented as disembodied, objective and inevitable, it is material, biased and subject to our own outlooks and ideologies."  
—**David A. Shaywitz, Wall Street Journal**

"As Kate Crawford's trenchant *Atlas of AI* demonstrates again and again, artificial intelligence does not come to us as a deus ex machina but, rather, through a number of dehumanizing extractive practices, of which most of us are unaware." —**Sue Halpern, New York Review of Books**

A leading scholar of artificial intelligence explores the ways in which AI is shaping contemporary culture: how it will change our lives, for better and for worse, and what it means to live in this crucial, watershed moment. The book will be structured around five parts, each centered on a basic ingredient of human creation: Words, Images, Sounds, Motion, and Systems. The chapters contend with how each element is transformed by AI systems, and how the industries that depend upon it are changing. Asking what does this mean for us, as individuals and as a society, Professor Crawford posits that the best way to understand the cultural metamorphosis underway is to start with how AI makes things for us, and what we are making of it. In this way, the book speaks to changes at the foundational level of human creation, as well as addressing a dramatic series of simultaneous industrial shifts.

**Kate Crawford** is a leading international scholar of artificial intelligence. She is a Distinguished Professor at USC Annenberg in Los Angeles, a Senior Principal Researcher at Microsoft Research, and the inaugural Visiting Chair for AI and Justice at the École Normale Supérieure in Paris. She has founded multiple research groups including FATE at Microsoft Research, the AI Now Institute at New York University, and the Knowing Machines Group at the University of Southern California. Her last book, *Atlas of AI: Power, Politics, and the Planetary Costs of Artificial Intelligence* (Yale University Press, 2021), won multiple awards including the prestigious Sally Hacker Prize, and was described by the *Financial Times* and *New Scientist* as one of the best books of the year.

**Read Write Own**  
Building the Next Era  
of the Internet  
**Chris Dixon**

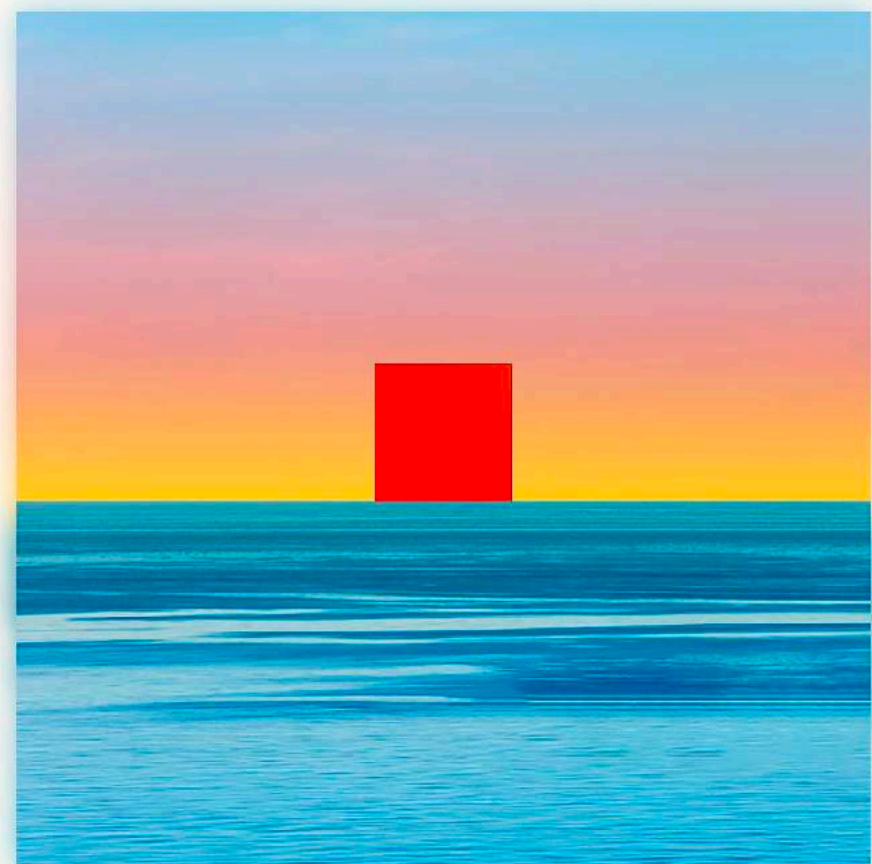

Random House - January 30, 2024

[blockchain](#) | [business](#) | [technology](#)

**Rights sold: Cornerstone Press (UK & BC), Alta Books (Brazil), CITIC (China), Across Publishing (Korea), Oceano (Spanish), MIF (Russia), Commonwealth (Taiwan)**

*Editor:* Ben Greenberg

*Agent:* Chris Parris-Lamb

*Material:* Awaiting 1st pass pages

*A potent exploration of the power of blockchains to reshape the future of the Internet—and how that affects us all—from highly influential entrepreneur and technology investor Chris Dixon*

---

**Major marketing campaign**  
**7 Foreign deals to date**

The Internet of today is a far cry from its early promise of a decentralized, democratic network of creativity and innovation. In the past decade, the Internet has fallen under the control of a tiny group of massive companies like Apple, Google, and Facebook. In *Read Write Own*, tech visionary Chris Dixon argues that the dream of an open network for fostering creativity and entrepreneurship doesn't have to die, and that in fact it can, and must, be saved with blockchain networks, which he vitally separates from the currency-based speculation that it is unfortunately lumped together with—a distinction he calls “The Computer vs The Casino”. With lucid and compelling prose—and drawing from his first-hand observations, mental models, and experiences over a 25-year career in the Internet industry—Dixon shows how the Internet has undergone three distinct eras, bringing us to the critical moment we're in today. The first act was the “read era,” lasting from 1990 to 2005, in which early Internet networks democratized information. In the “read-write era,” 2006-2020, corporate networks democratized publishing. And we are now entering the “read-write-own era,” sometimes called web3, in which blockchain networks have begun to democratize ownership, granting power and economic benefits to the participants in the network—not just to massive corporations.

Whether or not you care about blockchains, Bitcoin, or NFTs, *Read Write Own* is a must-read for anyone—internet users, business leaders, artists, creators, entrepreneurs, the tech curious—to understand where we've been and where we're going. It provides a playbook for the digital horizon, an argument for a better Internet, and a clarion call for anyone looking to navigate and build the future.

**Chris Dixon** is a general partner at Andreessen Horowitz, joining the storied venture capital firm in 2013, where he invested in Oculus (later acquired by Facebook), Coinbase, and other companies. He also placed early bets on Kickstarter, Pinterest, Stack Overflow, Stripe—all of which have products in wide use today. Dixon founded and leads Andreessen Horowitz's a16z crypto, which he has grown from \$300 million in 2018 to over \$7 billion of committed capital dedicated to investing in crypto and web3 technologies. He was ranked #1 on the *Forbes* Midas List of the world's best venture capital investors in 2022. Dixon has Bachelor of Arts and Masters degrees in Philosophy from Columbia University, an MBA from Harvard Business School, and founded two startups (acquired by McAfee and eBay). He lives in California and grew up in Ohio, where he started programming as a young child on an Atari 800.

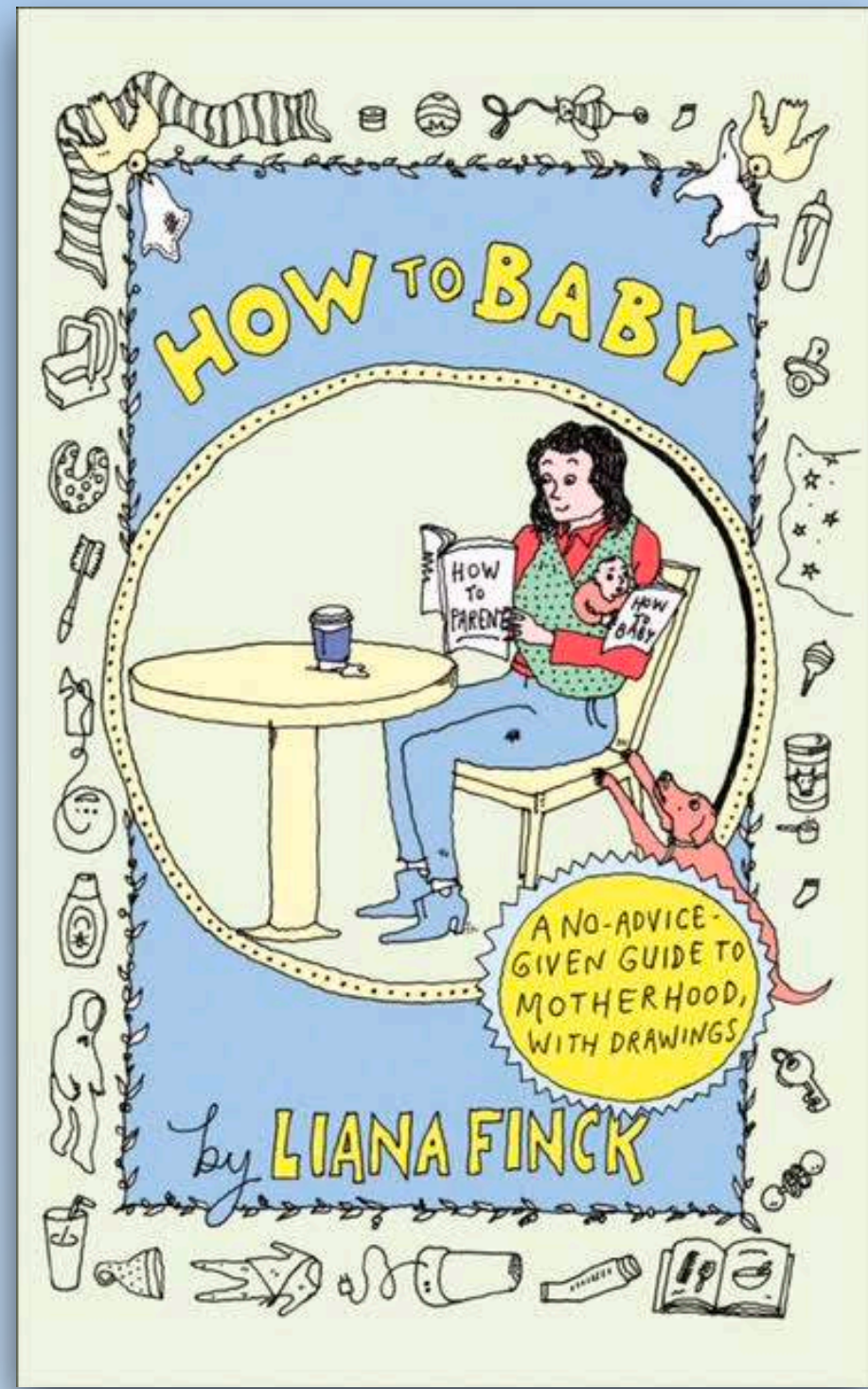

The Dial Press - April 16, 2024

[motherhood](#) | [graphic memoir](#) | [humor](#)

*Editor:* Andy Ward & Whitney Frick

*Agent:* Meredith Kaffel Simonoff

*Material:* Awaiting 1st pass pages

*A wryly personal and deeply relatable graphic memoir skewering the “traditional” parenting book to chronicle the absurdities, frustrations, and soaring joys of new parenthood--from the acclaimed New Yorker cartoonist and author*

---

How do you know if you're ready to have a baby? How do you know if you might be pregnant? And how do you deal with peeing all the time and being hungry all the time and fielding well-meaning but kind of insulting advice and finding a doula and being dropped by your old friends and learning why it's called mom brain and not dad brain and the tyranny of the milestones you're not meeting and negotiating boundaries with in-laws and realizing that your heart now exists outside of your chest and in the body of this tiny little being whose entire existence depends on the quality of your care?

To tackle these questions and many others, award-winning cartoonist and memoirist Liana Finck began illustrating her early years of motherhood, giving images and language to her insecurities, frustrations, and wild joy.

In *How to Baby*, Liana takes her witty and lacerating cartoons ("Hobbies for Pregnant Women: Waiting on Hold with the Insurance Company") and weaves them together with comic essays ("You Married a Brute. Worse. You're a Nag: Go Ahead and Argue with Each Other"), handy lists ("Nesting. The Comprehensive List of What to Buy and Why Getting Things Used Is Dangerous and Unamerican"), and profound observations. Together, these brilliant pieces form an immersive and comprehensive narrative whole—a baby book, a resource, and an emotional balm—for our time.

**Liana Finck** is the author of *Let There Be Light*, *Passing for Human*, and *Excuse Me*, and a children's book, *You Broke It!*, and is a regular contributor to *The New Yorker*. She is a recipient of a Guggenheim Fellowship, a Fulbright Fellowship, a Mandel Institute Cultural Leadership Fellowship, and a Wallant Award. She has had artist residencies with the American Academy in Berlin, MacDowell, and Yaddo.

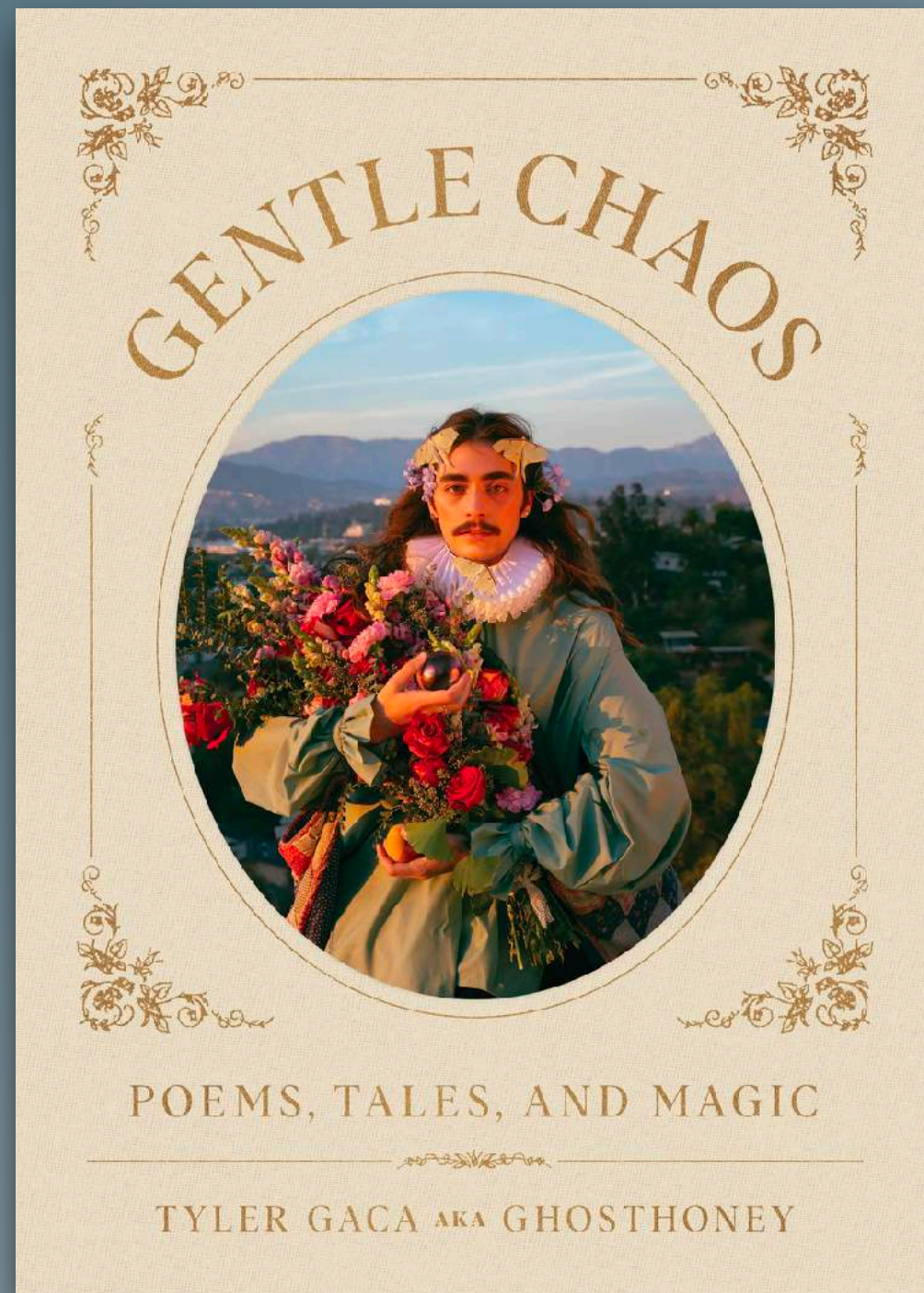

Running Press - October 3, 2023

[poems](#) | [LGBTQ+](#) | [magic](#)

*Editor:* Shannon Kelly

*Agent:* Seth Fishman

*Material:* Final pages

*From the wild imagination of Tyler Gaca, also known as TikTok's Ghosthoney, comes a beautiful compendium of poems, images, personal stories, and vignettes that explore magic, queerness, Tyler's unique story, and the enchantment and comfort to be found in the weird, the dark, and the different.*

---

In this raw yet enchanting collection of poems, essays, photographs, and artworks, Tyler Gaca dreamily navigates themes of magic and queerness, offering readers an intimate look inside his mind and his worlds, real and imagined. The writings in *Gentle Chaos* reflect on growing up queer and in love with magic, discovering yourself and your place in the world, and daring to seek out love and hope. The artworks are dedicated to salvaged antique photographs, haircuts, dead moths, the creatures we dream up, and much more. The result is a whimsical, vulnerable, and transporting journey into the gentle chaos within us all.

One day I will be gone / One day this page will be gone / One day someone else will read this /  
One day they will be gone too

One day we'll all be together / One day we'll all become one

How privileged I feel to take the moments / That are so small and so beautiful / So mundane and significant /  
So quiet and ephemeral / And make them big / within this small book

How magic it is / to make something personal / into something communal / In hopes that it will help. / In hopes that it will  
find its way / To someone who needs it

To share yourself with the world / is just as sad as it is sweet

Is just as much a relief as it is a burden

This to me, and me alone / Is delicious and sacred

This is gentle chaos

**Tyler Gaca** is an artist currently living in Los Angeles with his husband, a menagerie of animals, and many plants. In 2019, he began posting comedic videos on TikTok under the name Ghosthoney, and he has since built a career out of his surreal and offbeat sense of humor and his love and fascination for all things magical and morbid.

*An unprecedented and intimate portrait of Russia, and a fearless cri de cœur for journalism in opposition to the global authoritarian turn.*

---

**10 Foreign deals to date**

“Would you like to know where Putin comes from? What the Russians are like today? And why? Read this book.” —**Svetlana Alexievich, Nobel Prize winner and author of *Secondhand Time***

“Sharp-edged . . . harrowing . . . With gritty determination, she ventures beyond the Kremlin and its state-managed propaganda . . . Kostyuchenko’s journalistic integrity is unquestionable and the dangers she faces are very real. It’s a vivid and poignant account.” —**PW *\*starred review\****

“Elena Kostyuchenko is an important guide to the twenty-first century. The Russia she recounts here is the Russia we need to understand.” —**Timothy Snyder, author of *The Road to Unfreedom***

“Not only does Kostyuchenko find her way into the very darkness, she goes for its blackest corners. . . . The good news that emerges is her talent. Read her. It’s worth it.”  
—**Dmitry Muratov, editor-in-chief of *Novaya Gazeta* and winner of the Nobel Peace Prize**

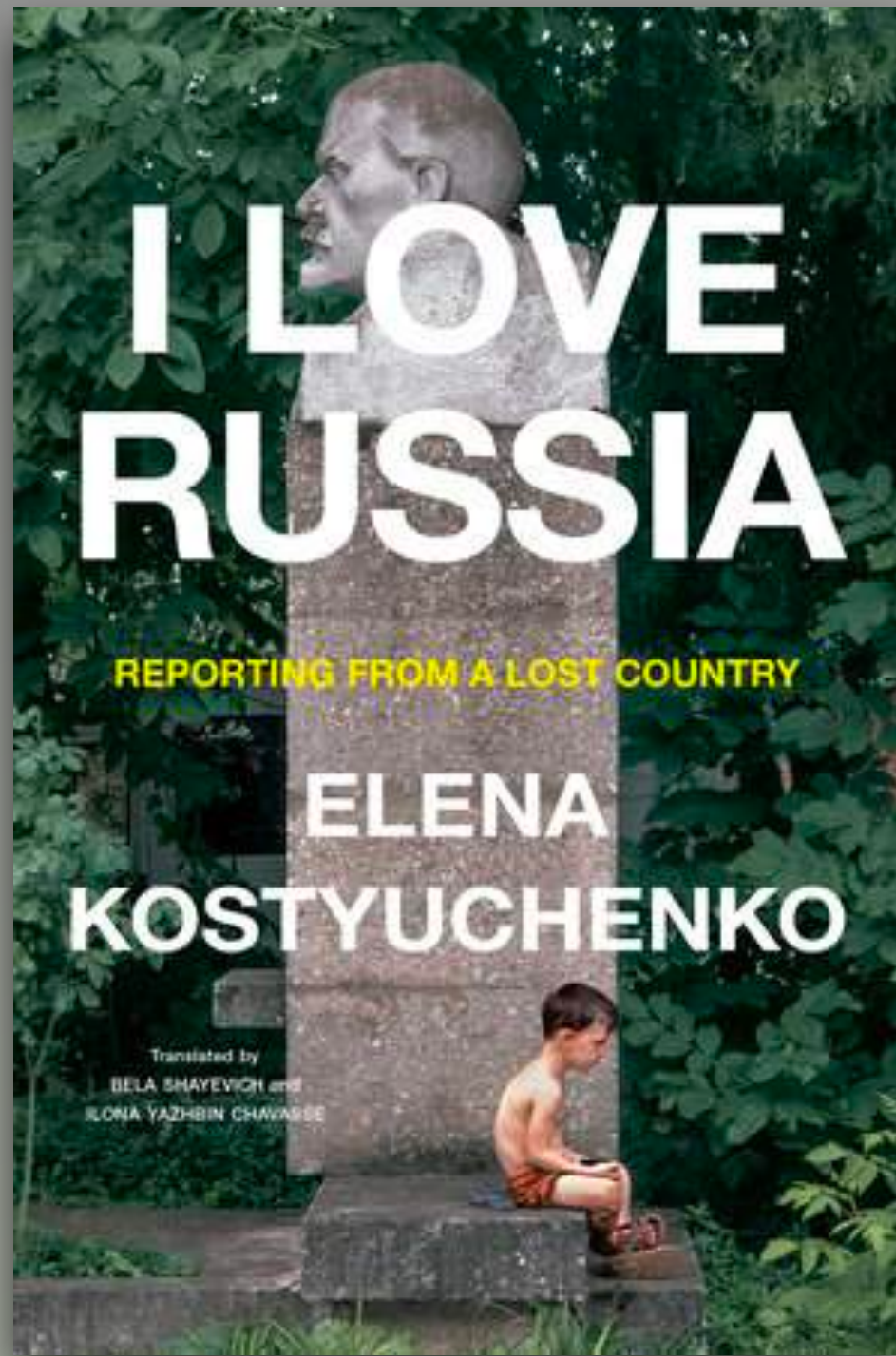

Penguin Press - October 17, 2023

[reportage](#) | [memoir](#) | [Russia](#)

**Rights sold: The Bodley Head (UK & BC), Acropolis (Taiwan), Janet 45 (Bulgaria), Argo (Czech Republic), Noir Sur Blanc (France), Penguin Verlag (Germany), Einaudi (Italy), Etcetra (Japan), Absynt (Slovakia), Ersatz Forlag (Sweden)**

*Editor:* Caroline Sydney

*Agent:* Chris Parris-Lamb

*Material:* 3rd pass pages

To be a journalist is to tell the truth. This is Elena Kostyuchenko’s fearless and unrelenting attempt to document Putin’s Russia as experienced by those whom it systematically and brutally erases: village girls recruited into sex work, queer people in the outer provinces, and reporters like herself. The result is a singular portrait of a nation, and of a woman who refuses to be silenced. In March 2022, as a reporter for Russia’s last free press, *Novaya Gazeta*, Kostyuchenko crossed the border into Ukraine to cover the war. It was her mission to ensure that Russians witnessed the horrors Putin was committing. She filed her pieces knowing that should she return home, she would likely be sentenced to 15 years in prison. Yet, driven by the conviction that the greatest form of love and patriotism is criticism, she continues to write, undaunted and with eyes wide open. *I Love Russia* stitches together reportage from the past 15 years with personal essays, assembling a kaleidoscopic narrative that Kostyuchenko understands may be the last thing she’ll publish for a long time — perhaps ever.

**Elena Kostyuchenko** is a journalist at *Novaya Gazeta*, Russia’s recently-decommissioned independent newspaper. At just 34 years old, Elena has been responsible for some incredible and brave coverage of Russia today and in recent years. She has been profiled recently in *Le Monde* and elsewhere in the European press.



HarperOne - February 27, 2024

[essays](#) | [literary criticism](#) | [humor](#)

**Rights sold:**

**Virago (UK & BC), Bompiani (Italy)**

*Editor:* Rakesh Satyal

*Agent:* Alia Hanna Habib

*Material:* copyedited ms

*From the celebrated national bestselling novelist and critic, a groundbreaking collection of essays exploring the state of cultural criticism and what meaning art has in our ever-challenging world.*

---

**New non-fiction from the author of the highly-acclaimed novel *Fake Accounts***

[Praise for Lauren Oyler](#)

"A century ago New York City got Edith Wharton; now the World Wide Web gets Lauren Oyler. We're even." —**Ron Charles, *The Washington Post***

Lauren Oyler has emerged as one of the most trenchant, influential, and revelatory critics of her generation, a talent who famously skewers and celebrates literary works with unsparing acuity. Her writing—acerbic, prismatic, and staggering in its genius and forthrightness—has crashed the *London Review of Books* website twice. Oyler delights in using her biting insights like a crowbar, whether smashing shibboleths in her essays or shattering conventions in her first novel *Fake Accounts*. But what is the significance of being an author, critic, and social media personality in today's fraught world; how do these fragments form a whole and what is the relevance? Lauren's classic Oylerian response: Who cares? In this blistering, irreverent, and very funny manifesto, Oyler takes genuine pleasure in dissecting the forces that shape her life, as well as ours—our deeply-held notions of what constitutes the contemporary American experience. *No Judgment* takes on the political and cultural roots of joy, the psychology and influence of "hot takes," the rise of autofiction, and the elusive state of "cool." Oyler argues that art and ideas aren't "necessary"—but they matter implicitly. Explaining to readers, and herself, why—what "the stakes" are—has always been the goal of her writing. In this, her luminous and sometimes mind-bending first book of nonfiction, she encapsulates the world we live and think in with precision and care—delivering a witty, provocative, and brilliant work of cultural criticism as only she can.

**Lauren Oyler's** essays on books and culture appear regularly in *The New Yorker*, the *New York Times Magazine*, the *New York Times Book Review*, the *London Review of Books*, *Harper's*, the *Guardian*, *New York* magazine's *The Cut*, *Bookforum*, the *Baffler*, the *New Republic*, and other publications. From 2015 to 2017, she was an editor at *Broadly*, the now-defunct women's site at Vice. Before that, she was a freelance copy editor in Berlin. She co-wrote two books with Alyssa Mastromonaco and has ghostwritten other works as well. Her first novel, *Fake Accounts*, was a national bestseller and is currently being adapted into a television series. She lives in Berlin.

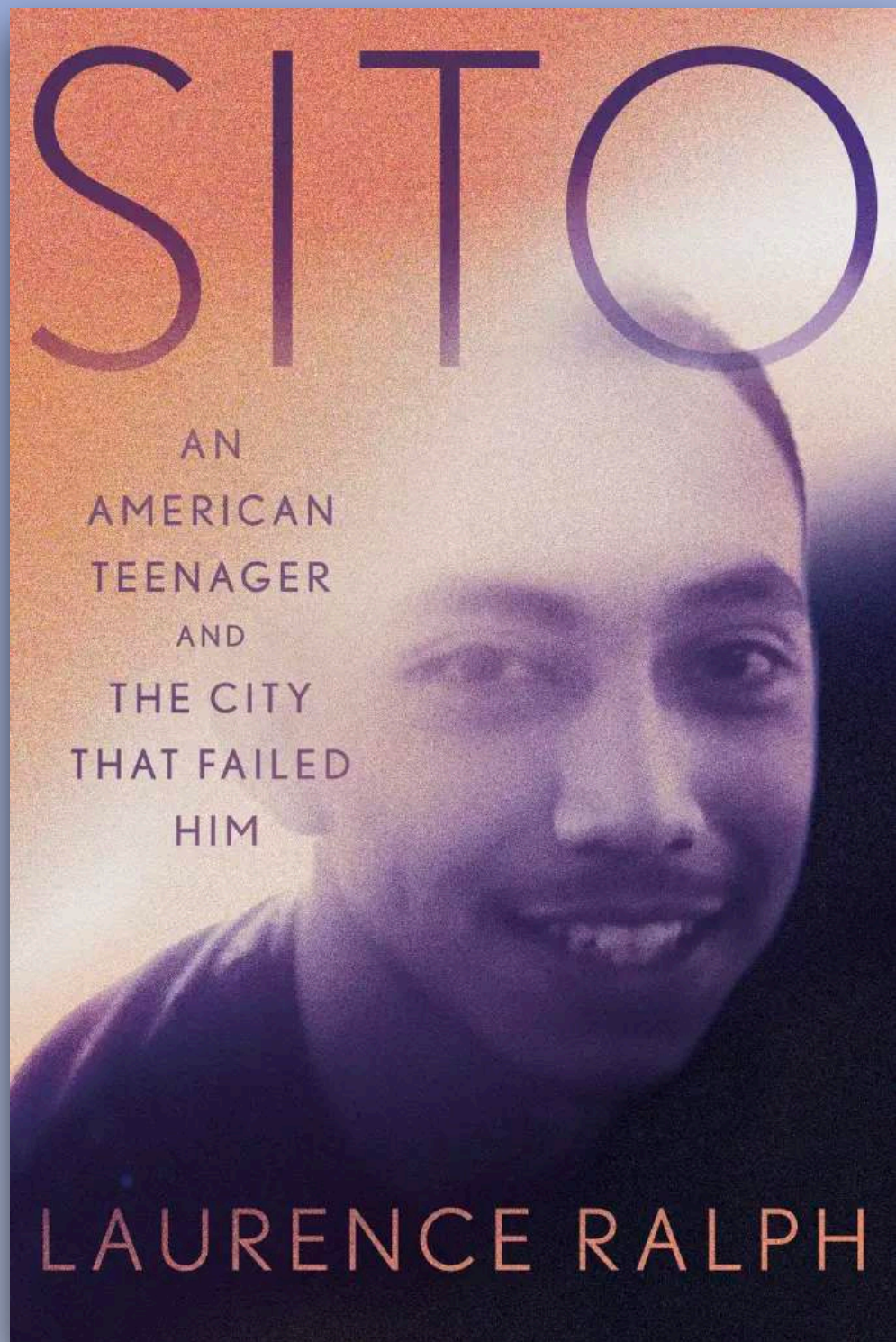

Grand Central - February 20, 2024

[sociology](#) | [memoir](#) | [justice system](#)

**Editor:** Maddie Caldwell

**Agent:** Chris Parris-Lamb

**Material:** 1st pass pages

*This heart-wrenching story of violence, grief and the American justice system, explores the systemic issues that perpetuate gang participation in one of the wealthiest cities in the world, as through the story of one teenager.*

---

"*Sito* is Laurence Ralph's most intimate, most searching, and most liberated work yet. Following the murder of a teenage family member, Ralph explores this gutting loss through the eyes of fathers and mothers, brothers and friends....With depths beyond depths, this profound book is a memoir and a sociological analysis; it is a critique, a confession, and a prayer."

—**Matthew Desmond, Pulitzer Prize-winning author of *Evicted***

Laurence Ralph ruminates on gang violence and our decadent criminal legal system through the life and tragic murder of his 19-year-old loved one, Sito. The blend of intimacy and authority, of self-and-structural reflection, of despair and expectation make for a profoundly affecting and edifying book. *Sito* is a triumph."

—**Ibram X. Kendi, Jr., National Book Award winner and *New York Times* bestselling author**

In September of 2019, Luis Alberto Quiñonez—known as Sito— was shot to death as he sat in his car in the Mission District of San Francisco. He was nineteen. His killer, Julius Williams, was seventeen. It was the second time the teens had encountered one another. The first, five years before, also ended in tragedy, when Julius watched as his brother was stabbed to death by an acquaintance of Sito's. The two murders merited a few local news stories, and then the rest of the world moved on. But for the families of the slain teenagers, it was impossible to move on. And for Laurence Ralph, the stepfather of Sito's half-brother who had dedicated much of his academic career to studying gang-affiliated youth, Sito's murder forced him to revisit a subject of scholarly inquiry in a profoundly different, deeply personal way. Written from Ralph's perspective as both a person enmeshed in Sito's family and as an Ivy League professor and expert on the entanglement of class and violence, *SITO* is an intimate story with a message about the lived experience of urban danger, and about anger, fear, grief, vengeance, and ultimately grace.

**Laurence Ralph** is a Professor of Anthropology at Princeton University, where he is the Director for the Center on Transnational Policing. He is the author of *Renegade Dreams: Living Through Injury in Gangland Chicago* (2014) and *The Torture Letters: Reckoning With Police Violence* (2020), both published by University of Chicago Press. He is currently a Guggenheim Fellow, a fellow of the Radcliffe Institute for Advanced Study, and a member of the Institute for Advanced Study at Princeton. He lives in Princeton, New Jersey with his wife and daughter.

*From the bestselling authors of Soonish,  
a brilliant and hilarious investigation into the realities of space settlement*

**More than 8,000 pre-orders**

“The cheeky tone is loads of fun, and Zach’s humorous illustrations of, for instance, contraptions proposed to facilitate zero-gravity sex, entertain. It adds up to a boisterous takedown of techno-utopianism.” —***Publishers Weekly, \*starred review\****

“An entertaining illustrated assessment of space settlement. This book is, to put it simply, a romp . . . A fun, informative read that puts the pop into popular science.” —***Kirkus***

“There is simply no more engrossing, entertaining, or thorough way to understand the intense challenge of humanity’s off-Earth future than *A City on Mars*. I laughed the whole way through.”  
—**Hank Green, *New York Times* bestselling author of *An Absolutely Remarkable Thing***

Earth is not well. The promise of starting life anew somewhere far, far away beckons, and settling the stars finally seems within our grasp. Or is it? Critically acclaimed, bestselling authors Kelly and Zach Weinersmith set out to write the essential guide to a glorious future of space settlements, but after years of research, they aren’t so sure it’s a good idea. Space technologies and space business are progressing fast, but we lack the knowledge needed to have space kids, build space farms, and create space nations in a way that doesn’t spark conflict back home. In a world hurtling toward human expansion into space, *A City on Mars* investigates whether the dream of new worlds won’t create nightmares, both for settlers and the people they leave behind. With deep expertise, a winning sense of humor, and art from the beloved creator of *Saturday Morning Breakfast Cereal*, the Weinersmiths investigate perhaps the biggest questions humanity will ever ask itself—whether and how to become multiplanetary.

**The Weinersmiths**, a wife-and-husband research team, cowrote the *New York Times* bestselling popular science book *Soonish*, a *Wall Street Journal* and *Popular Science* book of the year. **Dr. Kelly Weinersmith** is an adjunct faculty member in the BioSciences department at Rice University. Her research has been featured in *The Atlantic*, *National Geographic*, *BBC World*, *Science*, and *Nature*. **Zach Weinersmith** makes the webcomic *Saturday Morning Breakfast Cereal*. He illustrated the *New York Times* bestselling *Open Borders: The Science and Ethics of Immigration*, and his work has been featured in *The Economist*, *The Wall Street Journal*, *Slate*, *Forbes*, *Science Friday*, *Foreign Policy*, PBS, and elsewhere. The Weinersmiths live on an old farm in Virginia with their two children.

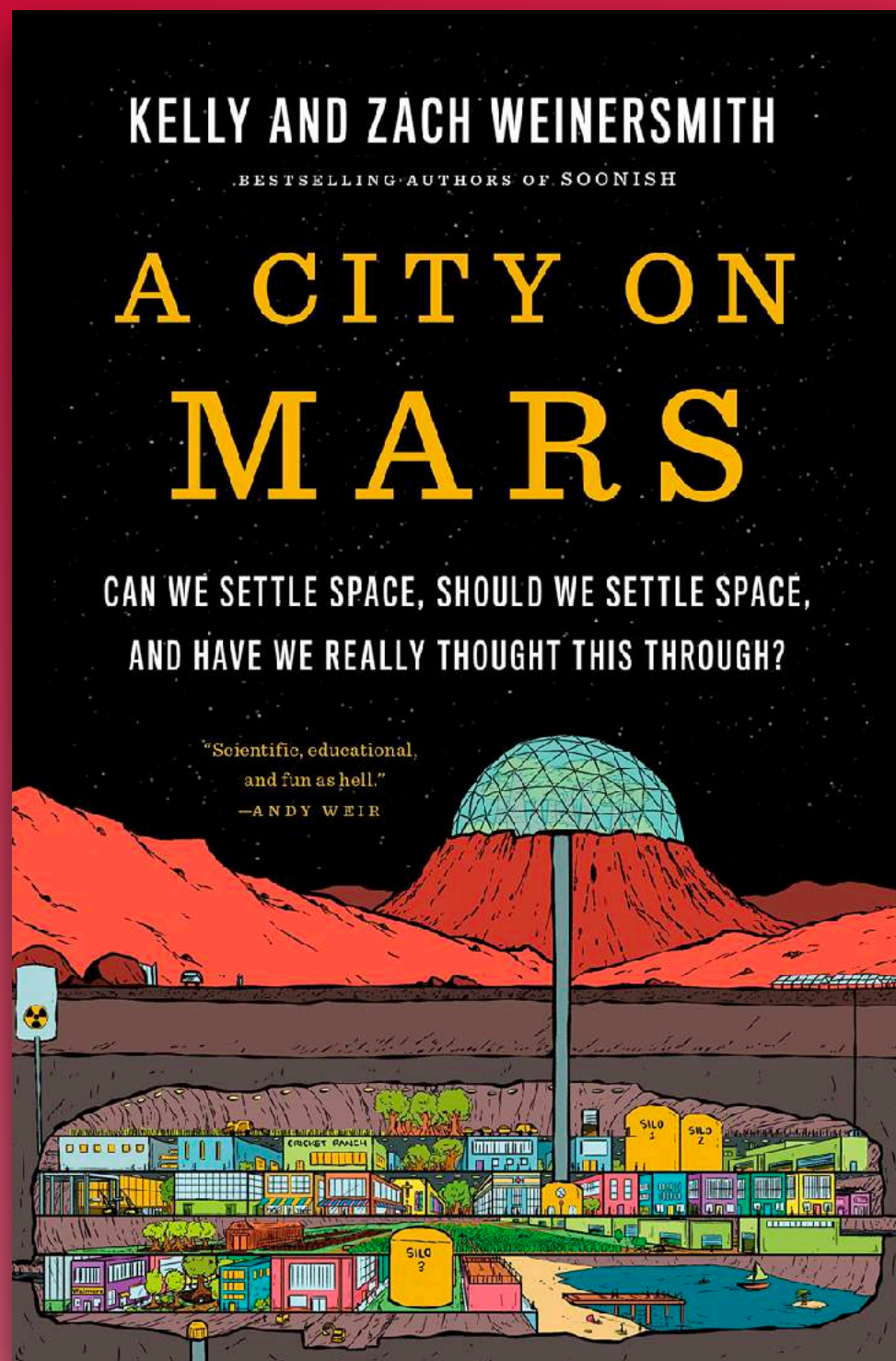

Penguin Press - November 7, 2023

[astrophysics](#) | [pop science](#) | [comics](#)

**Rights sold:**

**Penguin (UK & BC), Hangzhou Blue Lion (China), Insignis (Poland), Blackie Books (Spain), WeLearn (Thailand)**

*Editor:* Virginia Smith

*Agent:* Seth Fishman

*Material:* Final pages

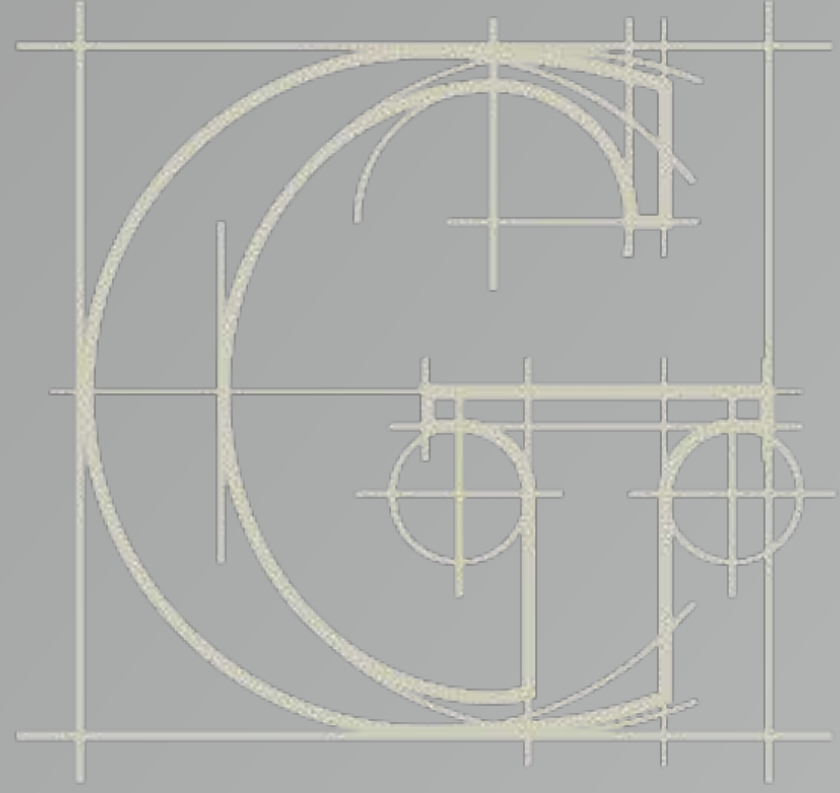

*the*  
**gernert**  
*company*

*More*  
*Opportunities*

fiction

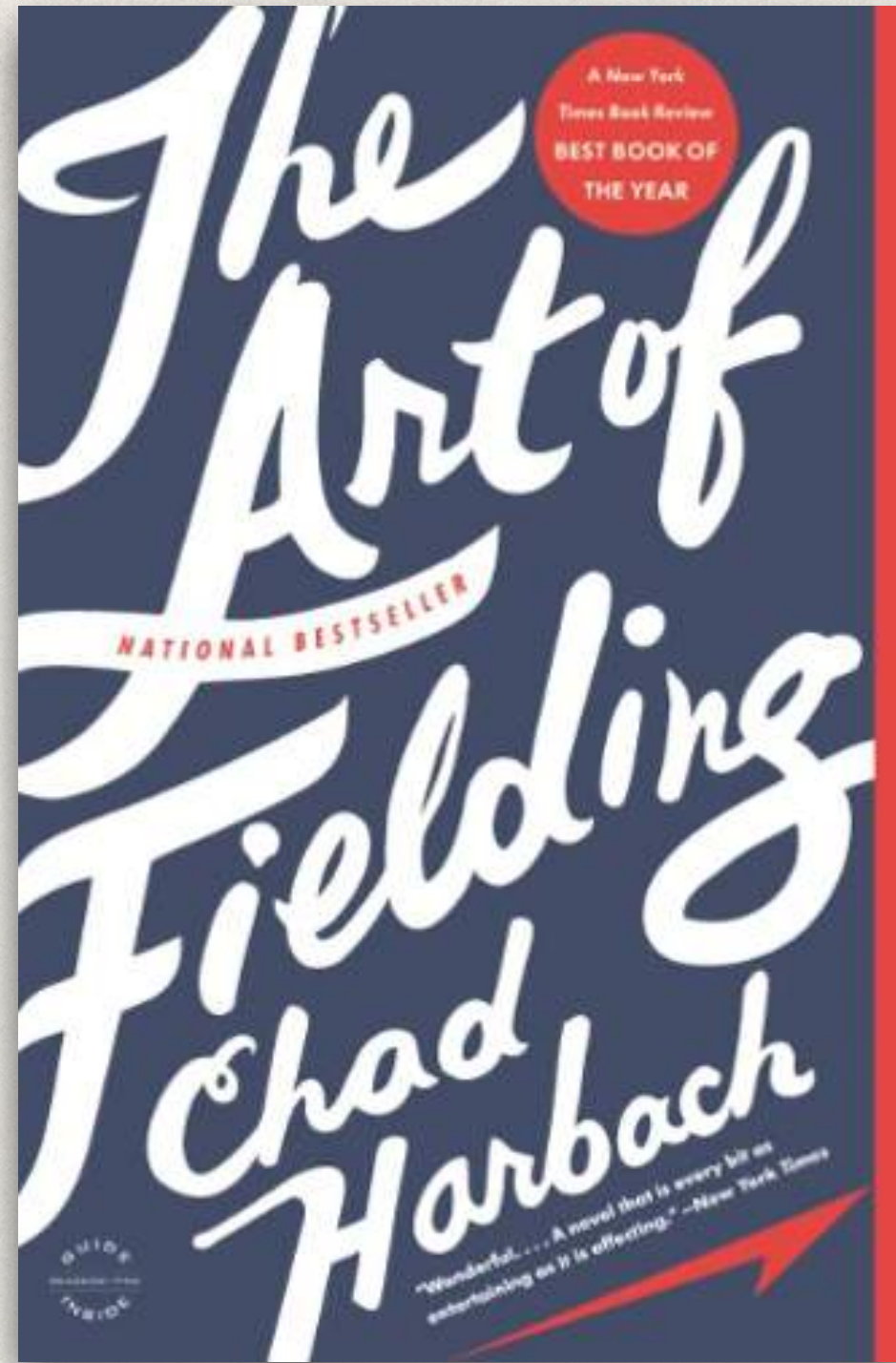

Little, Brown - September 7, 2011  
Agent: Chris Parris-Lamb

Star shortstop Henry Skrimshander seems destined for the big leagues, but when a routine throw goes disastrously off course, the fates of five people are upended.

**INTERNATIONAL BESTSELLER**  
More than 600,000 copies sold • Amazon's #1 Pick of 2011 • Chosen for 30 "Best Of" lists • 20 foreign deals

fiction

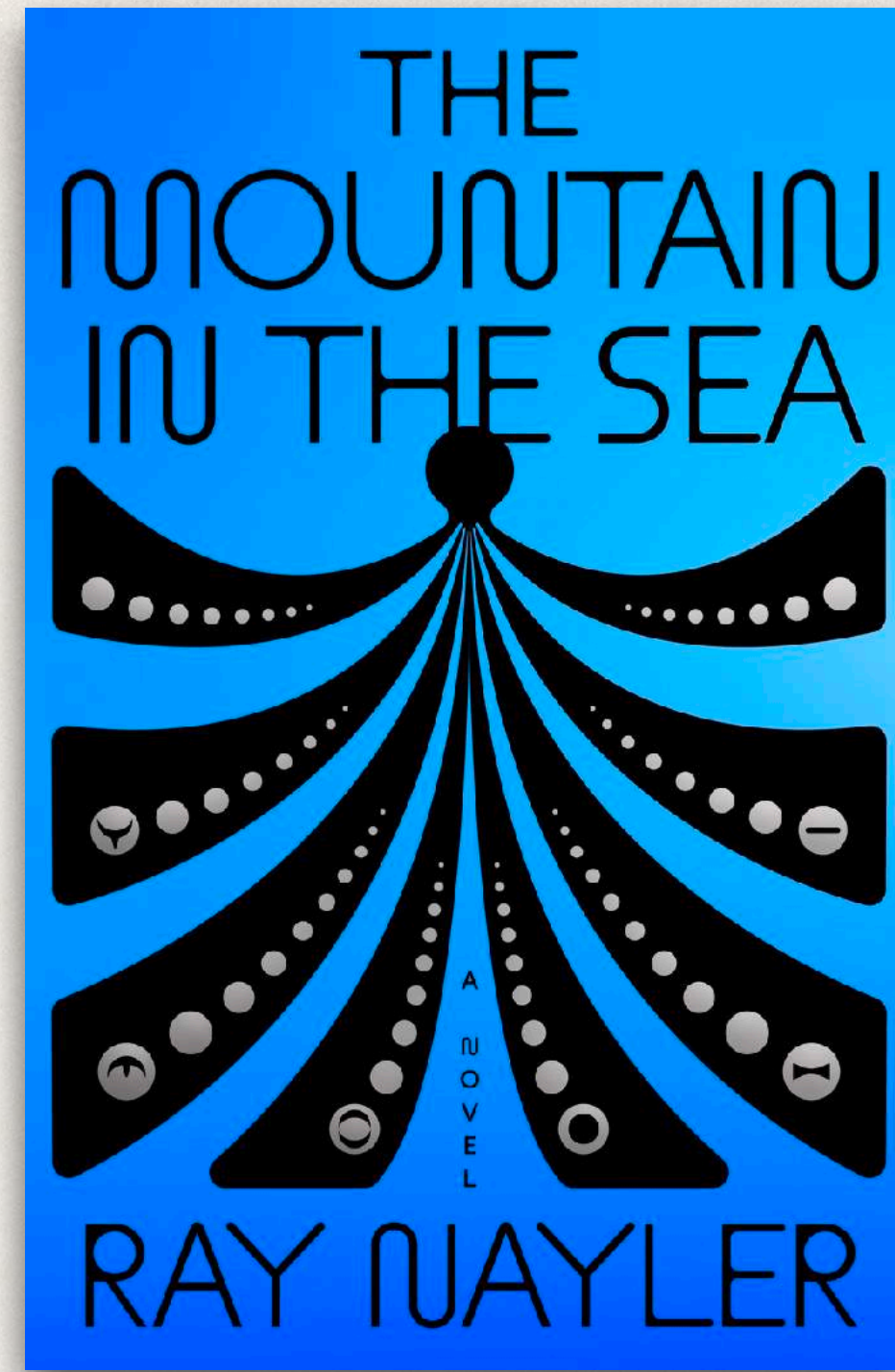

MCD - October 4, 2022  
Agent: Seth Fishman

This near-future thriller by an acclaimed short-story writer describes the nature of consciousness in a dazzling literary debut that takes a mind-blowing dive into humankind's legacy.

Lead title for MCD/FSG • Sold at auction in Germany • Blurbs from David Mitchell, Jeff VanderMeer, Blake Crouch, Robin Sloan, Ann Leckie

fiction

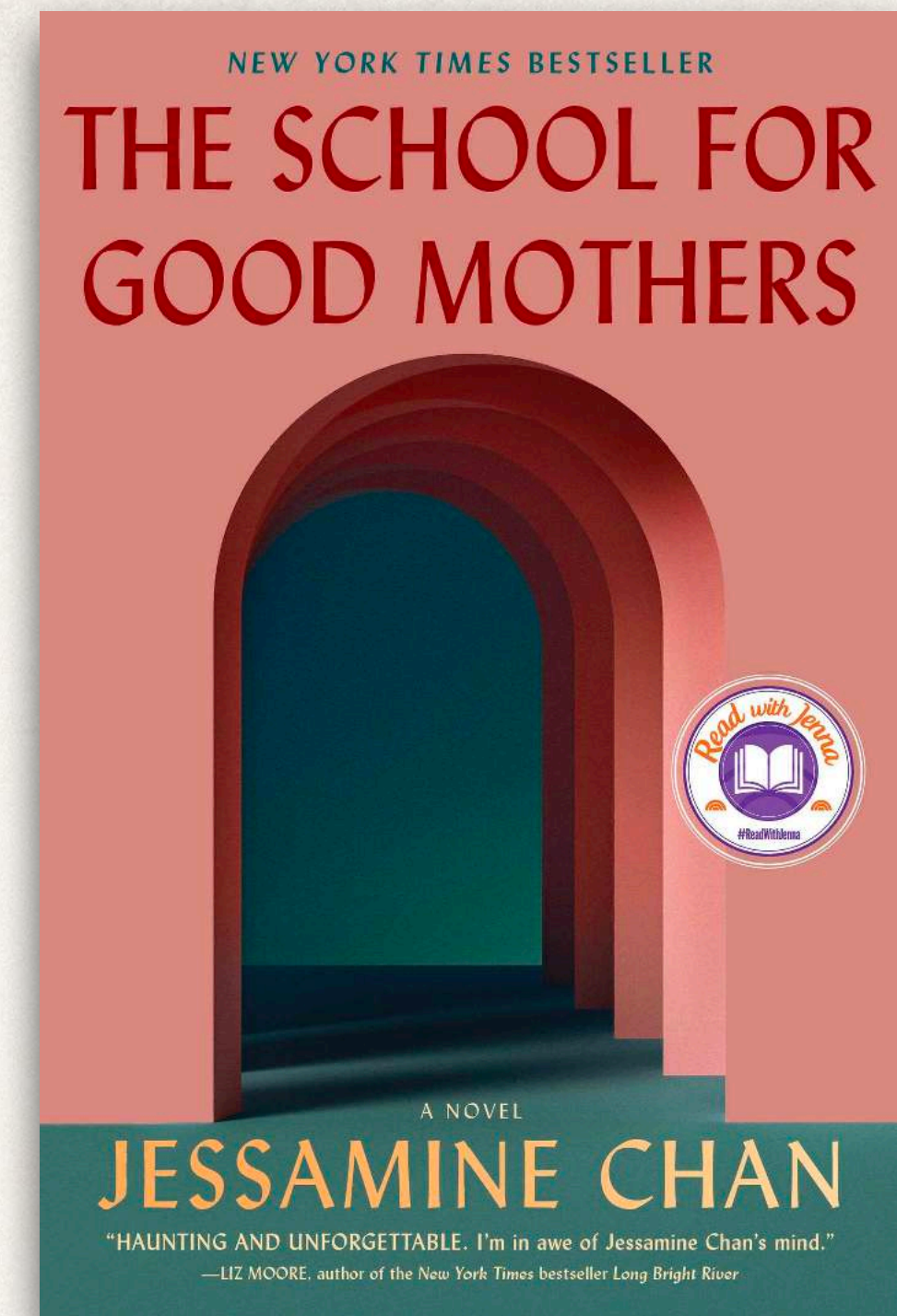

S&S - January 4, 2022  
Agent: Meredith Kaffel Simonoff

In this *New York Times* bestseller, one lapse in judgement lands a young mother in a government reform program where custody of her child hangs in the balance, in this debut novel.

**New York Times bestseller • Today show Read with Jenna Book Club Pick • Finalist for the NBCC / John Leonard Prize • Selected as One of Barack Obama's Favorite Books of 2022!**

fiction

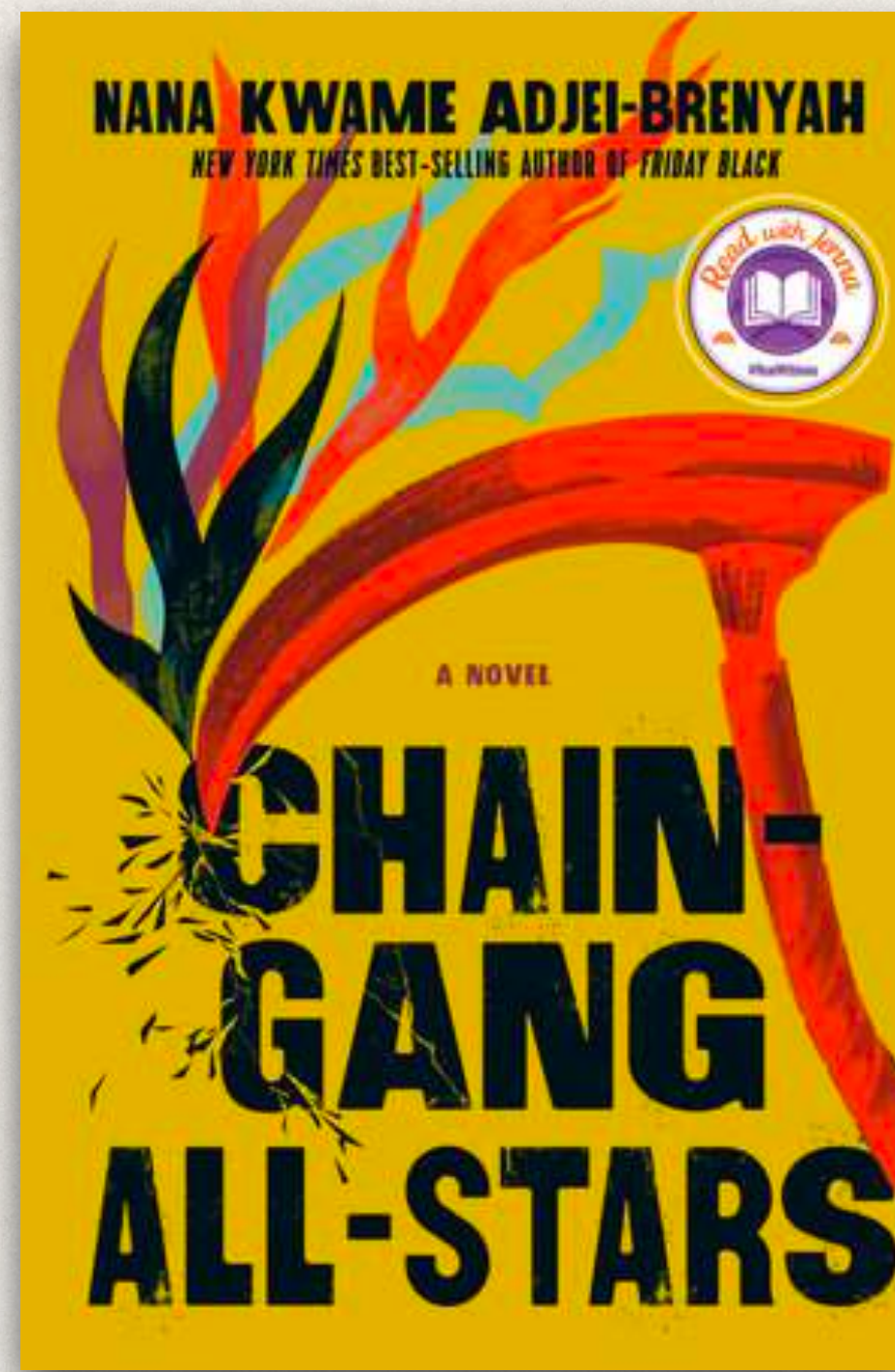

Pantheon - May 2, 2023

Agent: Meredith Kaffel Simonoff

This explosive debut about two women gladiators fighting for their freedom within a depraved private prison system is both a powerful love story and a clear-eyed reckoning with what freedom really means.

From the *New York Times*-bestselling author of *Friday Black* • A MOST ANTICIPATED TITLE OF THE YEAR: *Washington Post*, *Goodreads*, *Huffington Post*, *Lit Hub*, *The Millions*, *Publishers Weekly*, *Kirkus*, and many more

fiction

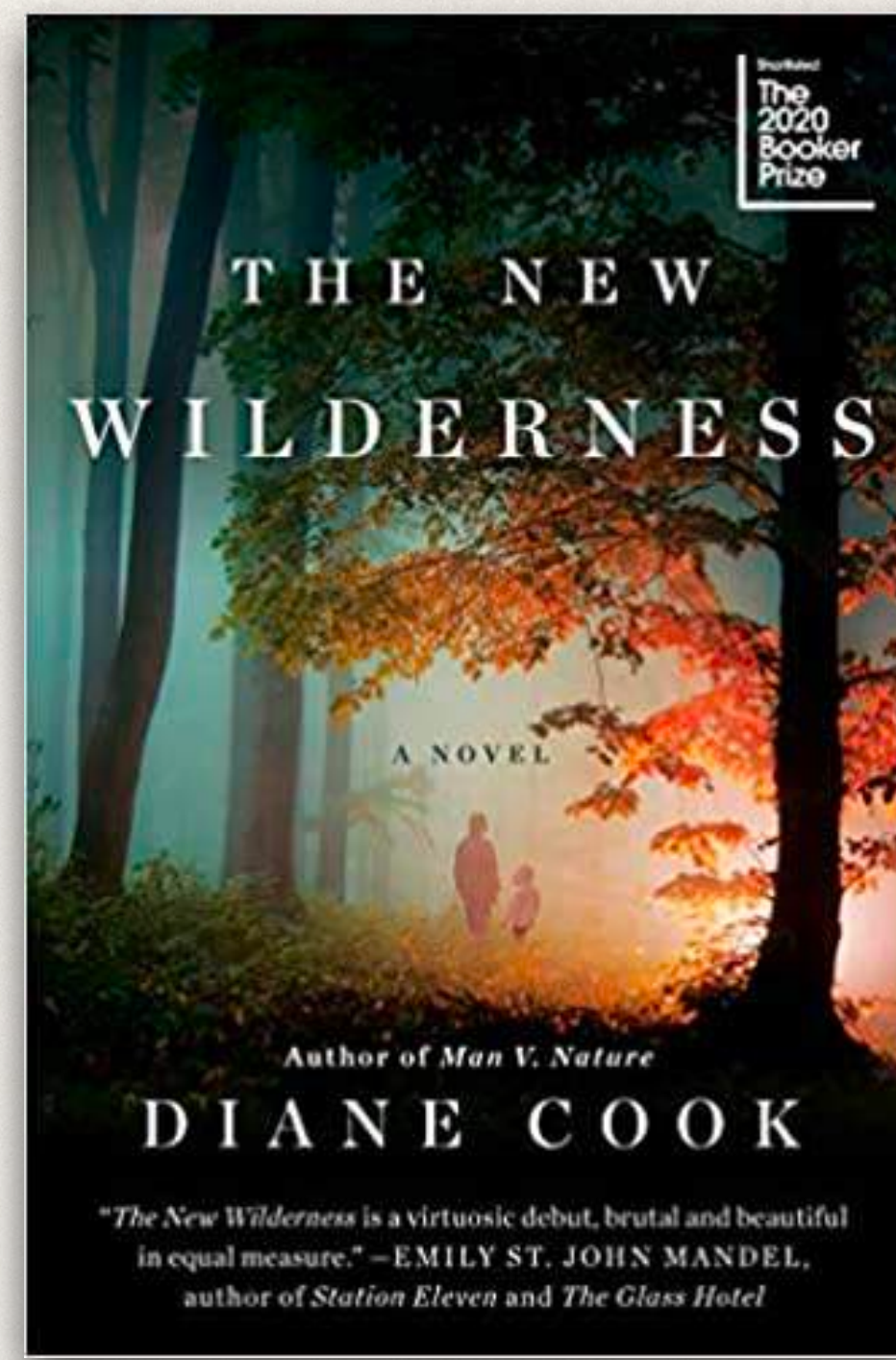

Harper - August 11, 2020

Agent: Seth Fishman

Helen Phillips meets Miranda July in this daring and imaginative debut novel that explores a moving mother-daughter relationship in a world ravaged by climate change and overpopulation.

Shortlisted for the Booker Prize 2020  
• TV rights sold to Warner Bros. at auction • Starred reviews in *Kirkus*, *Publishers Weekly*, and *Booklist* • Fifteen foreign deals!

fiction

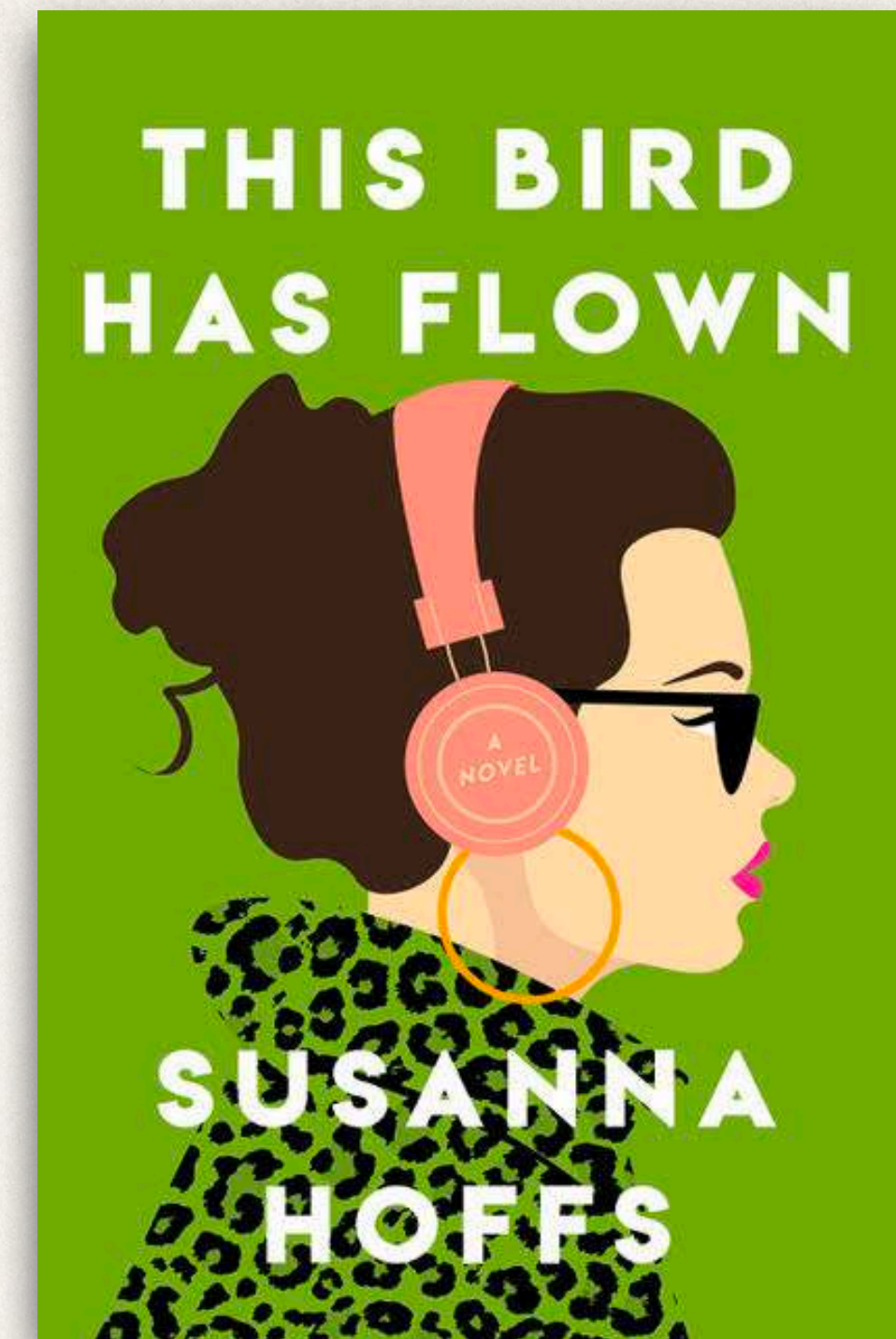

Little, Brown - April 4, 2023

Agent: Sarah Burnes

A delightfully funny and romantic debut that is “part British romcom, part *Jane Eyre*, and one hundred percent enjoyable” (Tom Perrotta).

Delightful debut novel from the lead singer of *The Bangles* • For lovers of *Daisy Jones & the Six* and *Jane Eyre* • Film rights under option

fiction

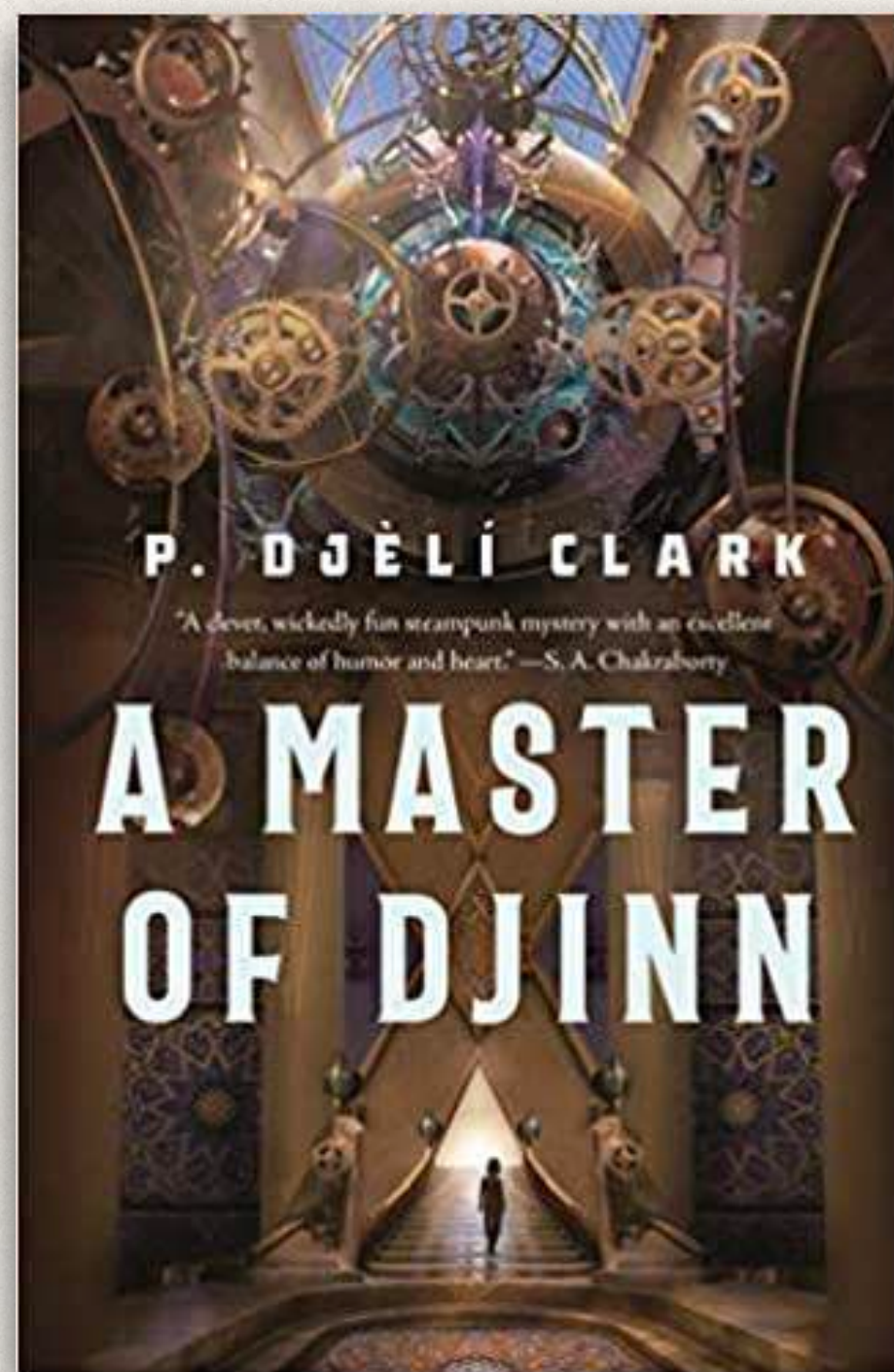

**Tor.com - May 11, 2021**  
**Agent: Seth Fishman**

Nebula, Locus, and Alex Award-winner P. Djèlí Clark returns to his popular alternate Cairo universe for his fantasy novel debut, *A Master of Djinn*.

**7 foreign deals • Won the 2021 Nebula for Best Novel • Clark is the winner of the Nebula, Locus and Alex awards • Blurbs from S. A. Chakraborty, Mary Robinette Kowal and Rebecca Roanhorse, among many others**

fiction

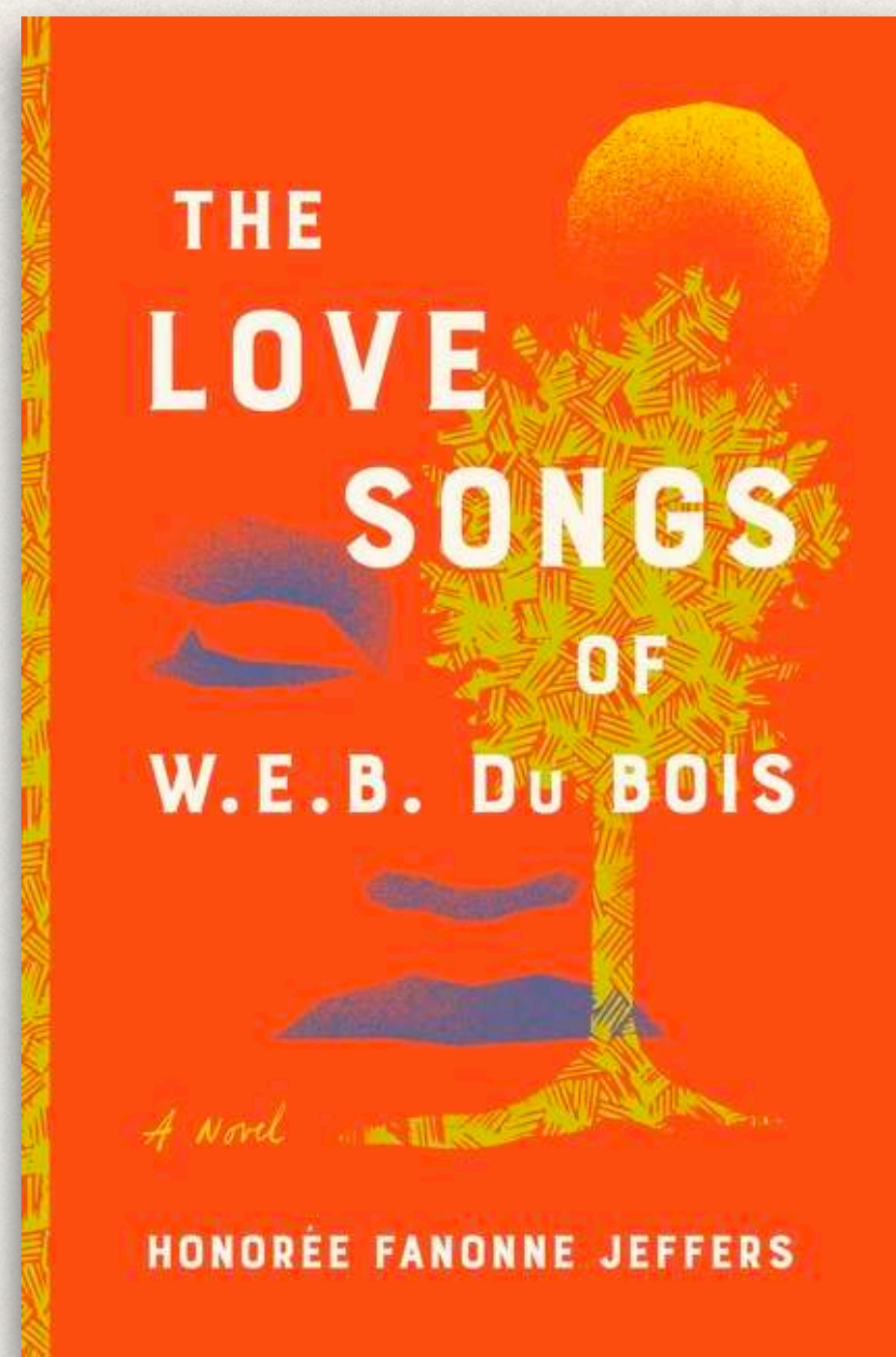

**HarperCollins - August 24, 2021**  
**Agent: Sarah Burnes**

Jeffers makes her fiction debut with this magisterial epic —an intimate yet sweeping novel that chronicles the journey of one American family from the centuries of the colonial slave trade through the Civil War to our own tumultuous time.

**New York Times bestseller • An Oprah Book Club Selection • 2020 National Book Award–nominated poet • Starred/rave reviews from PW, Booklist, Kirkus, New York Times Book Review, and more • 12 foreign deals**

fiction

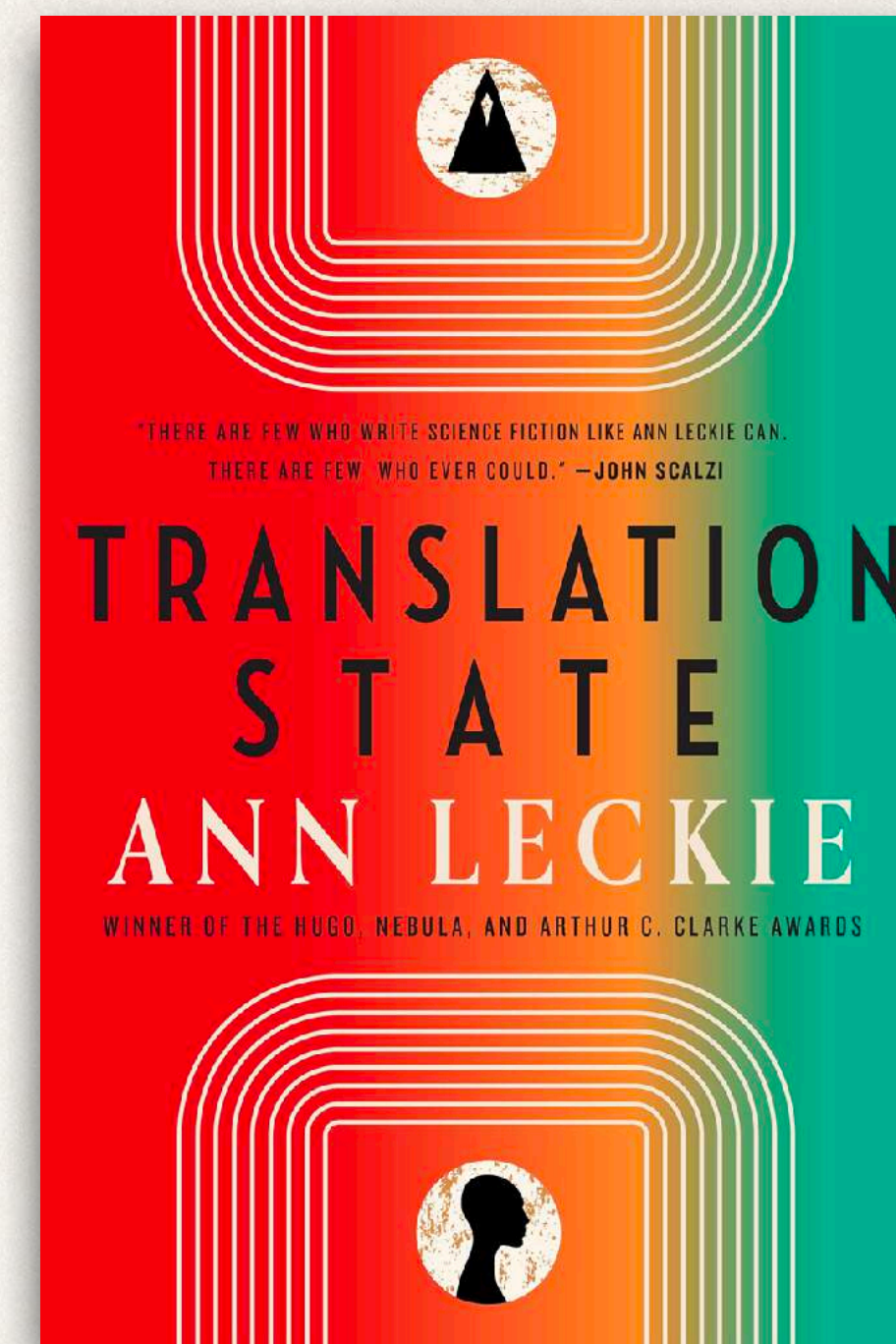

**Orbit - June 6, 2023**  
**Agent: Seth Fishman**

A stand-alone mystery set in Leckie's celebrated Imperial Radch universe about a missing translator who sets three lives on a collision course that will have a ripple effect across the stars

**From the winner of the Hugo, Nebula, and Arthur C. Clarke Awards, and New York Times bestselling author • More than 1 million copies of Ann Leckie's books sold worldwide • TV rights in development with Amazon and Kilter Films**

*fiction*

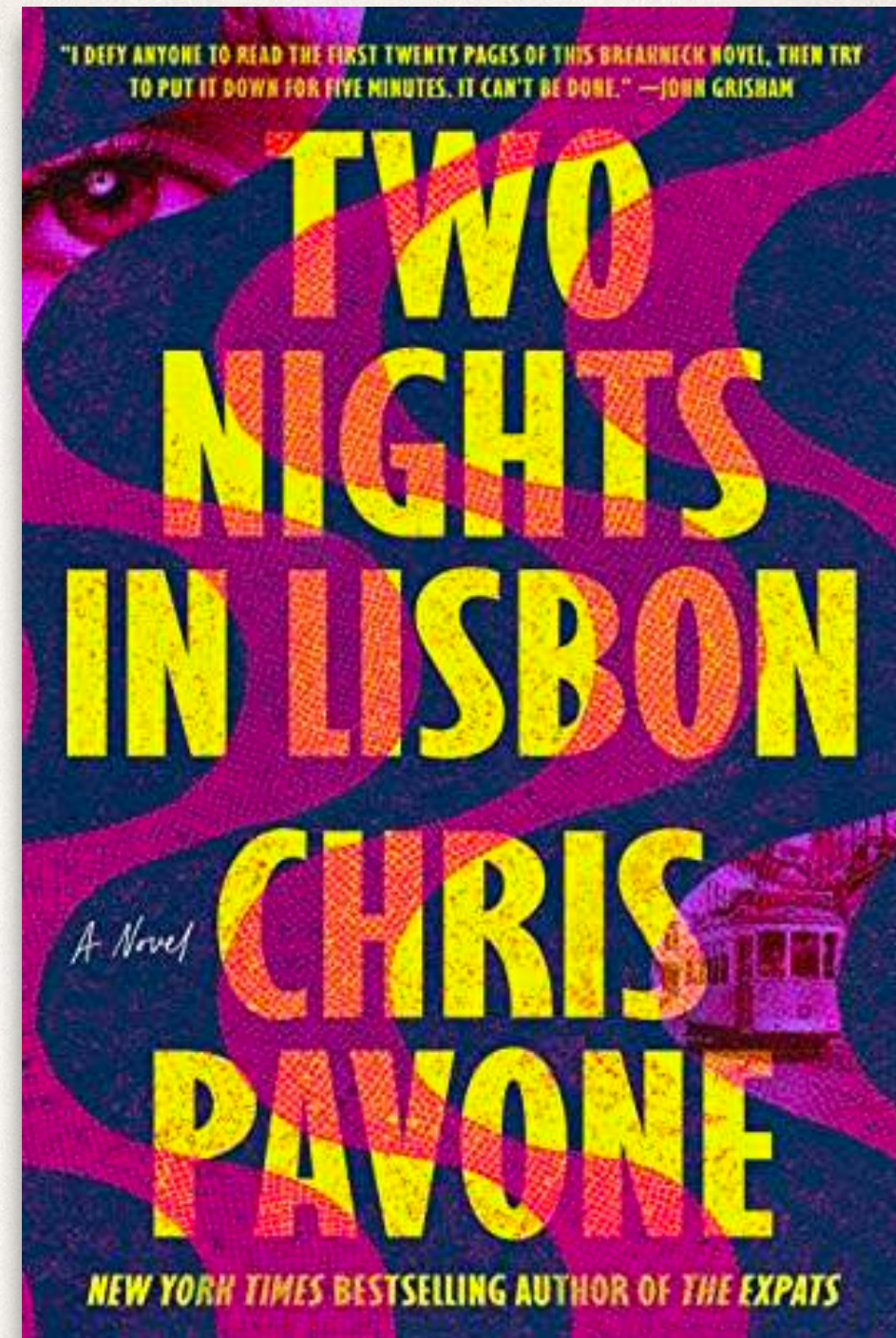

**MCD/FSG - May 24, 2022**  
**Agent: David Gernert**

Tautly wound and expertly crafted, a riveting thriller about a woman under pressure, and how far she will go when everything is on the line.

**An instant *New York Times* and national bestseller • Starred reviews from *Publishers Weekly* and *Kirkus***

*fiction*

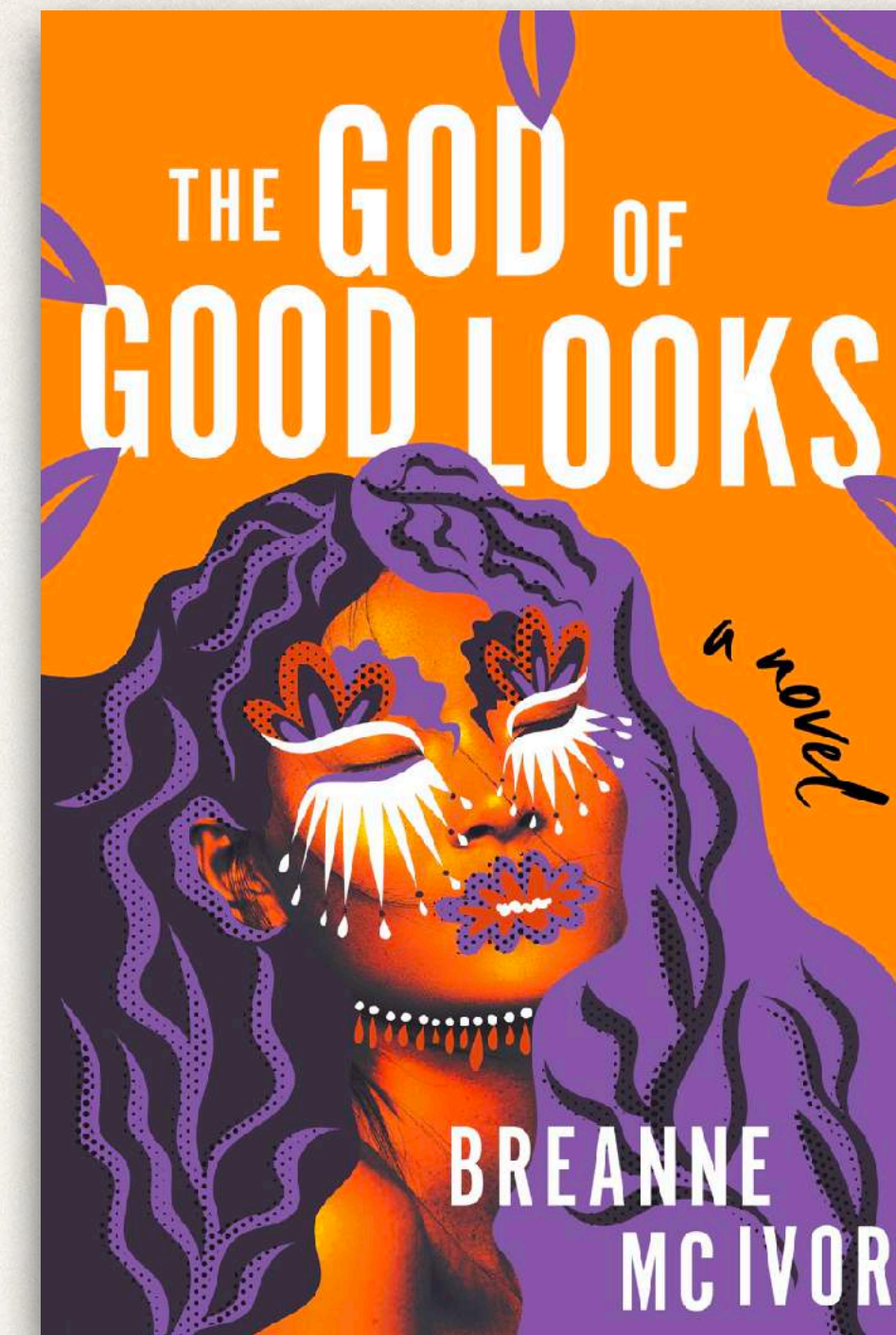

**William Morrow - May 16, 2023**  
**Agent: Meredith Kaffel Simonoff**

An entertaining, transportive, and luminous debut novel, which follows a young Trinidadian woman finding her voice and a new kind of happy ending.

**A sharp-witted and fiercely fun debut novel combining the honesty, warmth, and humor of *Queenie* and a modern-day *Bridget Jones's Diary* • Sold in the US and UK at auction**

non-fiction

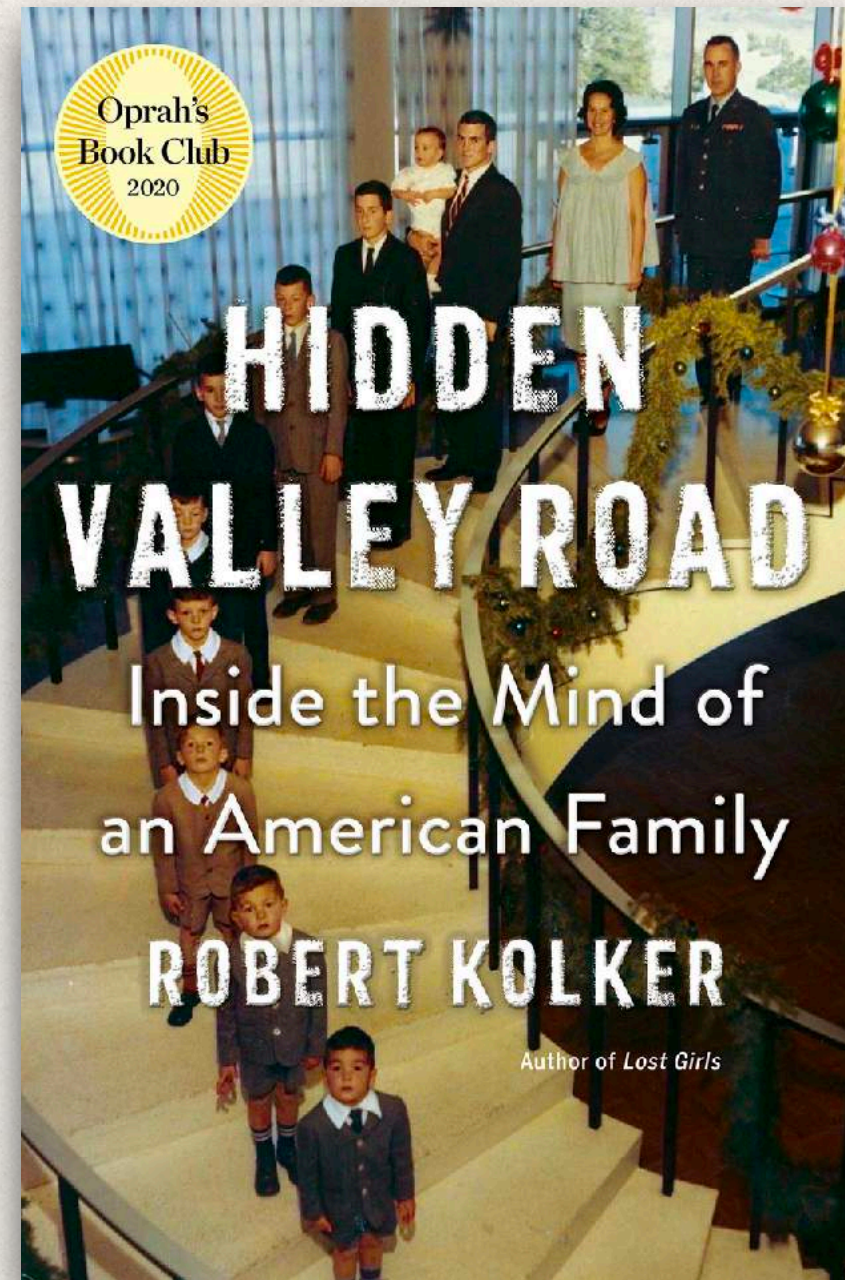

Doubleday - April 7, 2020

Agent: David Gernert & Chris Parris-Lamb

A riveting account of the Galvin family of Colorado Springs, Colorado, a midcentury American family with twelve children, six of whom were diagnosed with schizophrenia.

**Oprah's Book Club Pick • #1 New York Times bestseller • One of *The New York Times* top ten books of the year • One of *The Wall Street Journal* top ten books of the year • *People's* #1 Best Book of the Year • Named a Best Book of the Year by *The Washington Post*, NPR, *TIME*, *Slate*, *Smithsonian*, and Amazon. • Eight foreign sales**

non-fiction

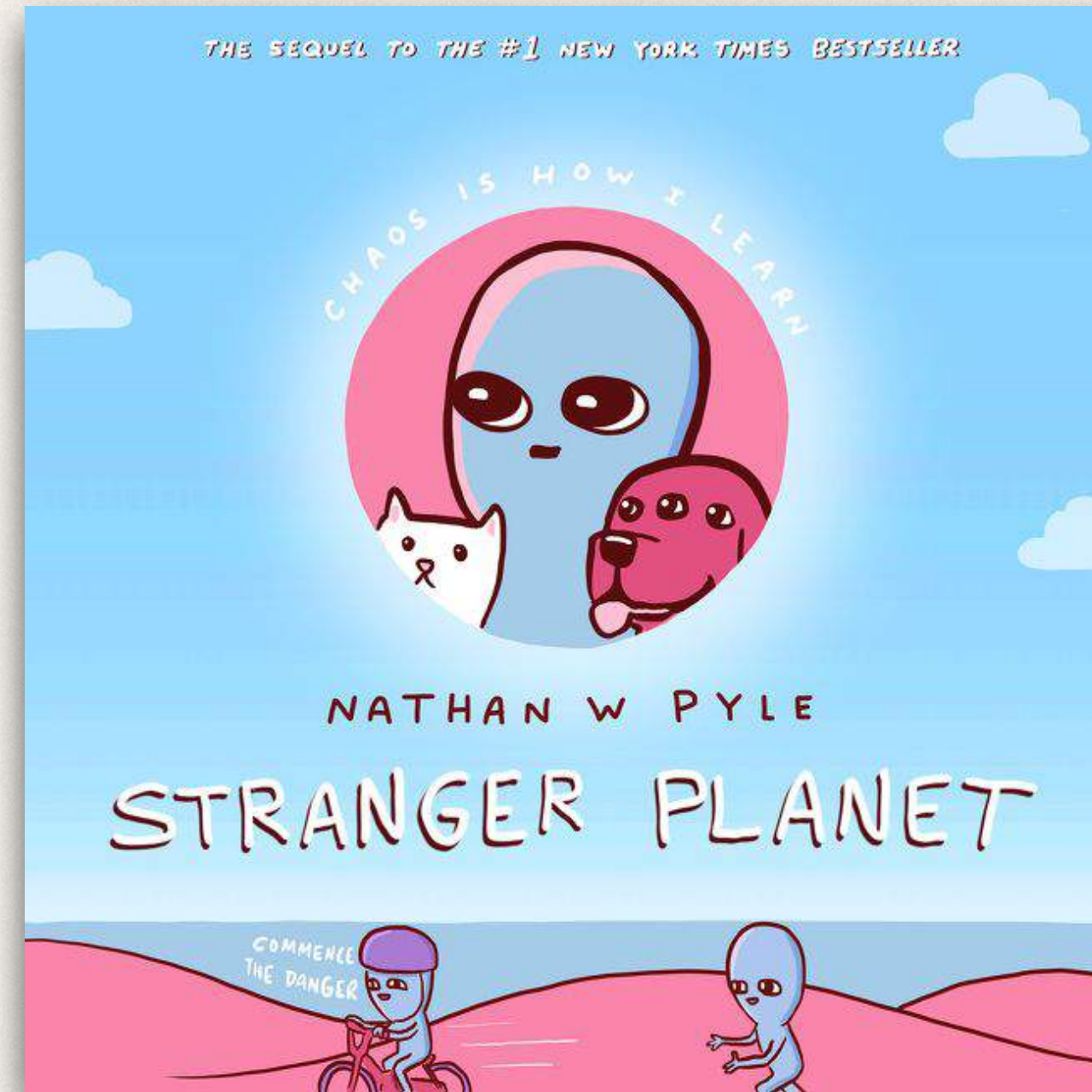

Morrow Gift - June 16, 2020

Agent: Seth Fishman

The sequel to the #1 *New York Times* bestselling phenomenon *Strange Planet*, featuring more hilarious adventures from the fascinating inhabitants of Nathan W. Pyle's colorful world.

**#1 New York Times bestseller • More than 500,000 copies sold of the *Strange Planet* books worldwide • The graphic novel based on the Instagram sensation with more than 6.0 million followers • Television show streaming now on Apple TV**

non-fiction



Doubleday - September 27, 2023

Agent: Chris Parris-Lamb

A gripping memoir on friendship, grief, the search for self, and the solace that can be found through art.

**Pulitzer Prize Winner • A *New York Times* Top Ten Book of the Year • National Book Critics Circle Award Winner • Named a Best Book of the Year by *The New York Times*, *The Washington Post*, *The New Yorker*, *TIME*, *The Atlantic*, *Kirkus*, *PW*, *NPR*, among others**

non-fiction

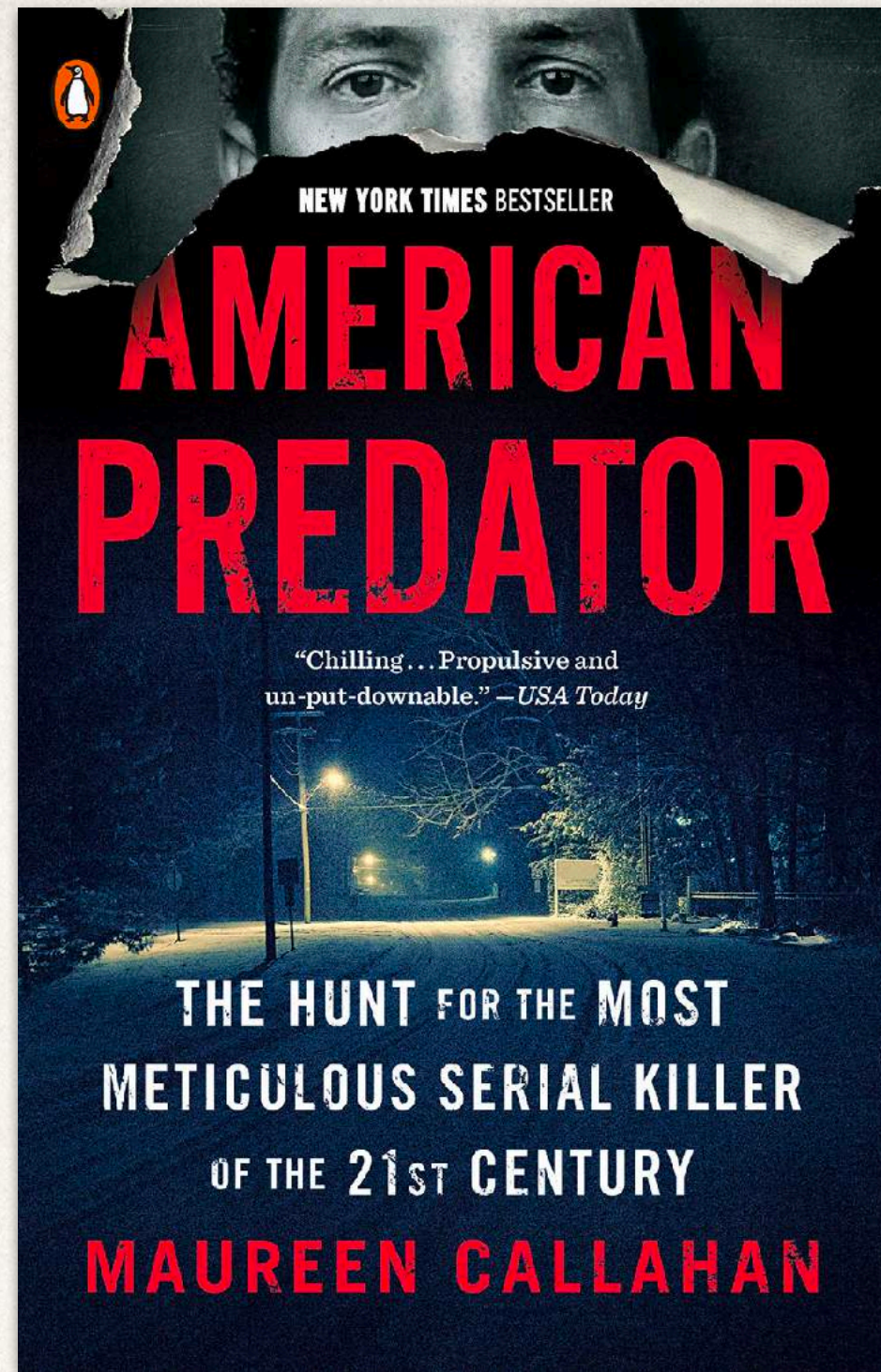

Viking - July 2, 2019  
Agent: Nicole Tourtelot

The names of notorious serial killers are usually well-known; they echo in the news and in public consciousness. But most people have never heard of Israel Keyes, one of the most ambitious and terrifying serial killers in modern history.

Instant *New York Times* bestseller •  
5 foreign deals • An Amazon  
"Best Book of 2019"

non-fiction

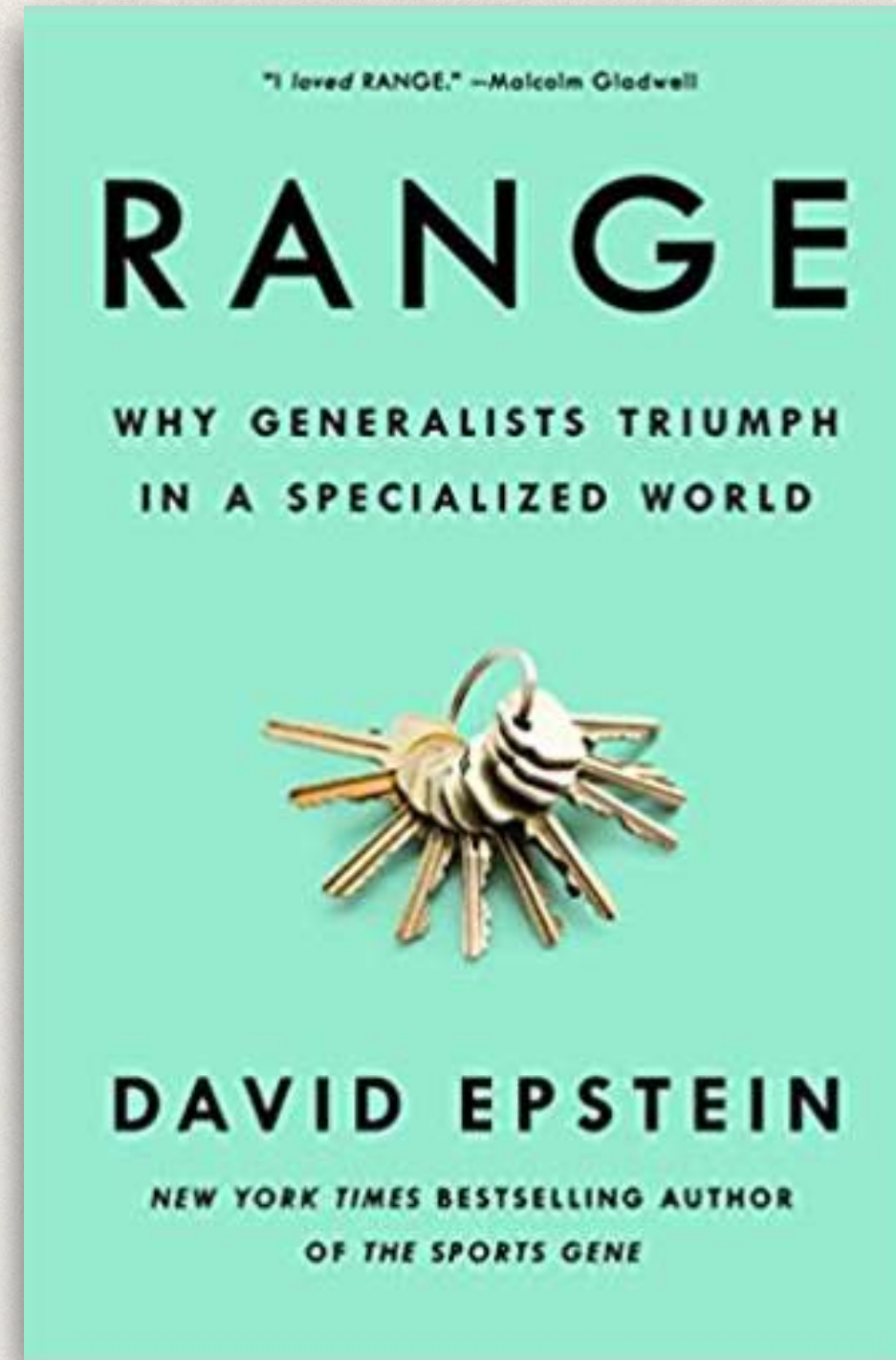

Riverhead - June 19, 2018  
Agent: Chris Parris-Lamb

What's the most effective path to success in any domain?  
It's not what you think.

# 1 *New York Times* bestseller •  
Sunday Times bestseller in the UK •  
Shortlisted for the FT Business Book of the Year • 25 foreign deals • Over a million copies sold worldwide

non-fiction

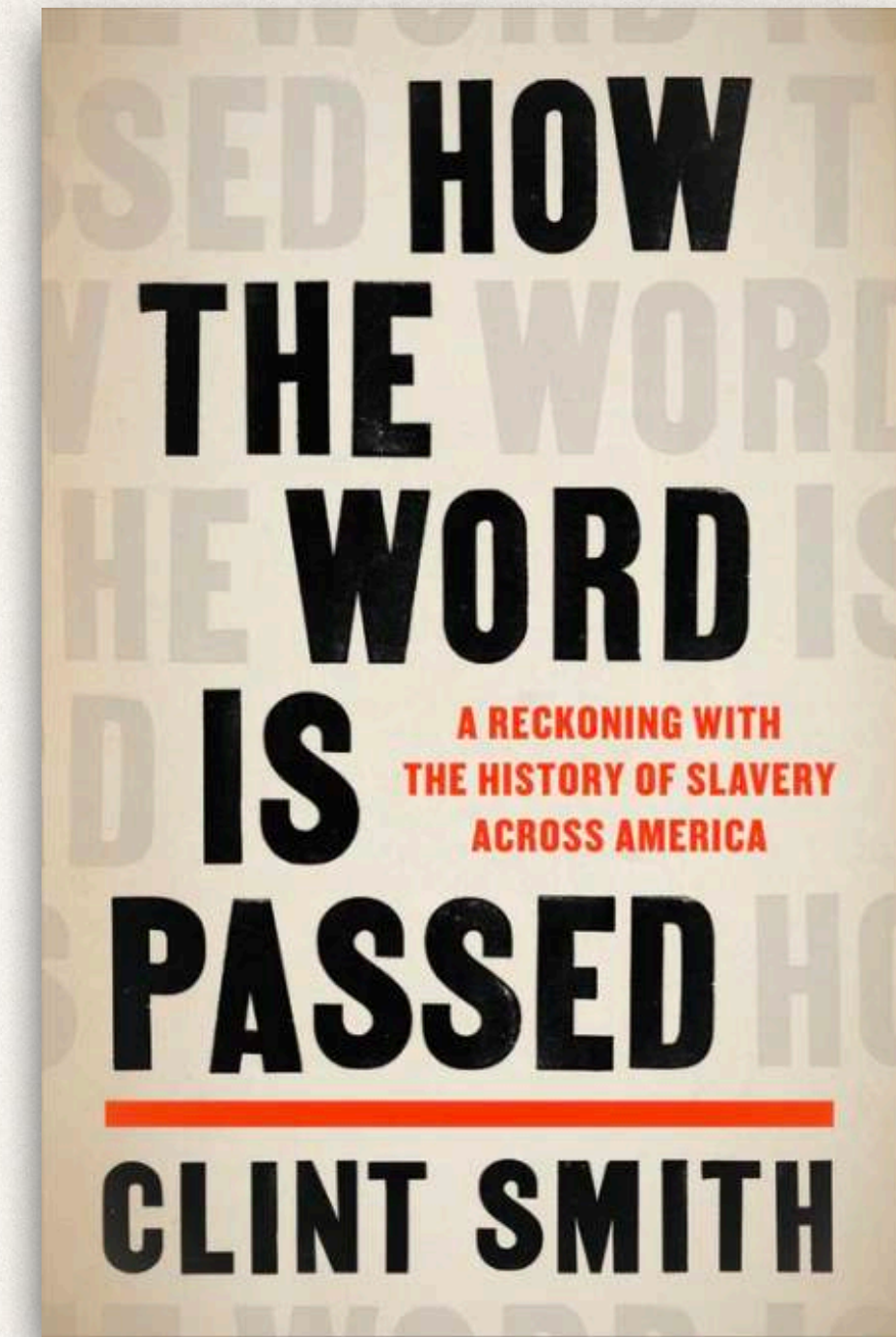

Little Brown - June 1, 2021  
Agent: Alia Hanna Habib

*The Atlantic* staff writer and poet Clint Smith's revealing, contemporary portrait of America as a slave owning nation.

Instant #1 *New York Times* bestseller •  
*New York Times* 10 Best Books of the Year •  
A *New York Times Book Review* Editor's Choice •  
NF title on the most Best Of Lists of 2021



non-fiction

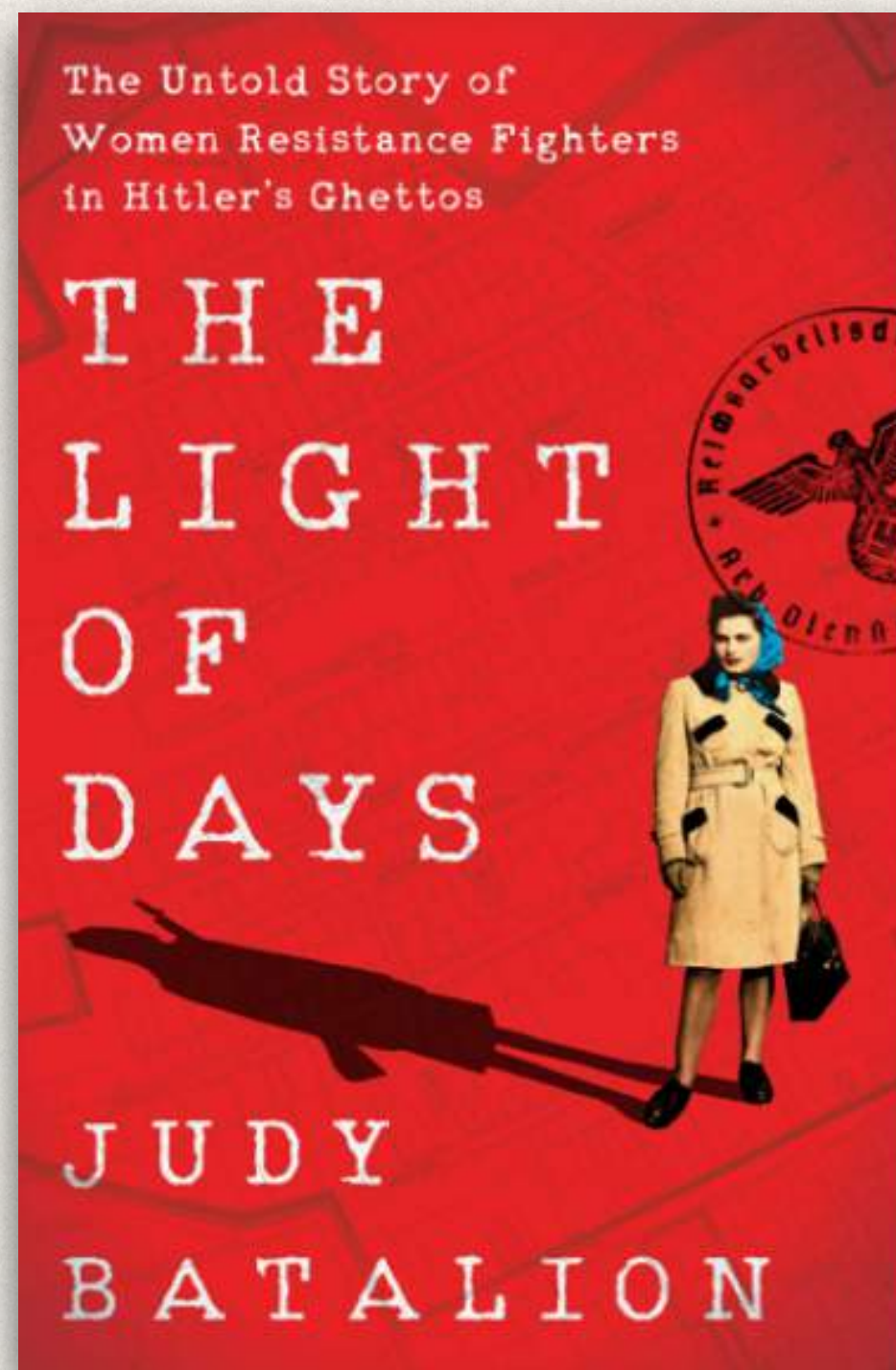

**William Morrow - April 6, 2021**  
**Agent: Alia Hanna Habib**

A spectacular, searing history that brings to light the extraordinary accomplishments of brave Jewish women who became resistance fighters.

**Top 5 New York Times Bestseller • Film rights optioned by Steven Spielberg • 100,000 copy first printing • 20 foreign deals**

non-fiction

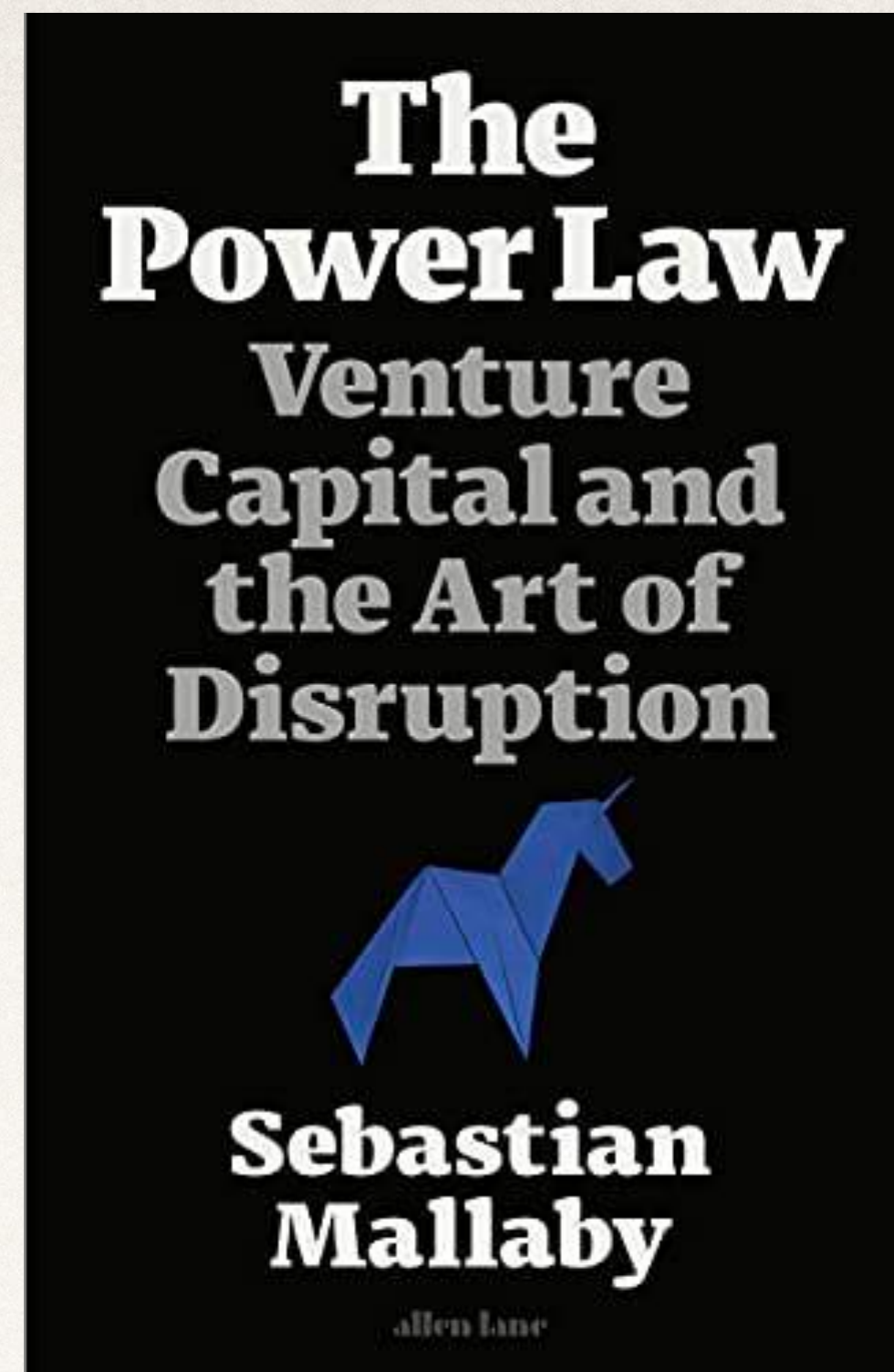

**Penguin Press - February 1, 2022**  
**Agent: Chris Parris-Lamb**

A frank and intimate story of Silicon Valley's dominant venture-capital firms—and how their strategies and fates have shaped the path of innovation and the global economy.

**A gripping, essential history of venture capital from a two-time Pulitzer Prize finalist • Raves from the WSJ and Washington Post • Foreign deals in 6 territories**

non-fiction



**Spiegel & Grau - March 22, 2022**  
**Agent: Chris Parris-Lamb**

A world-renowned future forecaster and game designer teaches us to envision the future and gives us the tools to help shape the world we want to live in.

**Sold in a six-figure preempt for NA • New York Times bestselling writer, Jane McGonigal's works have been published in 14 languages • Based on a class over 50,000 people have taken on Coursera.org**

*non-fiction*

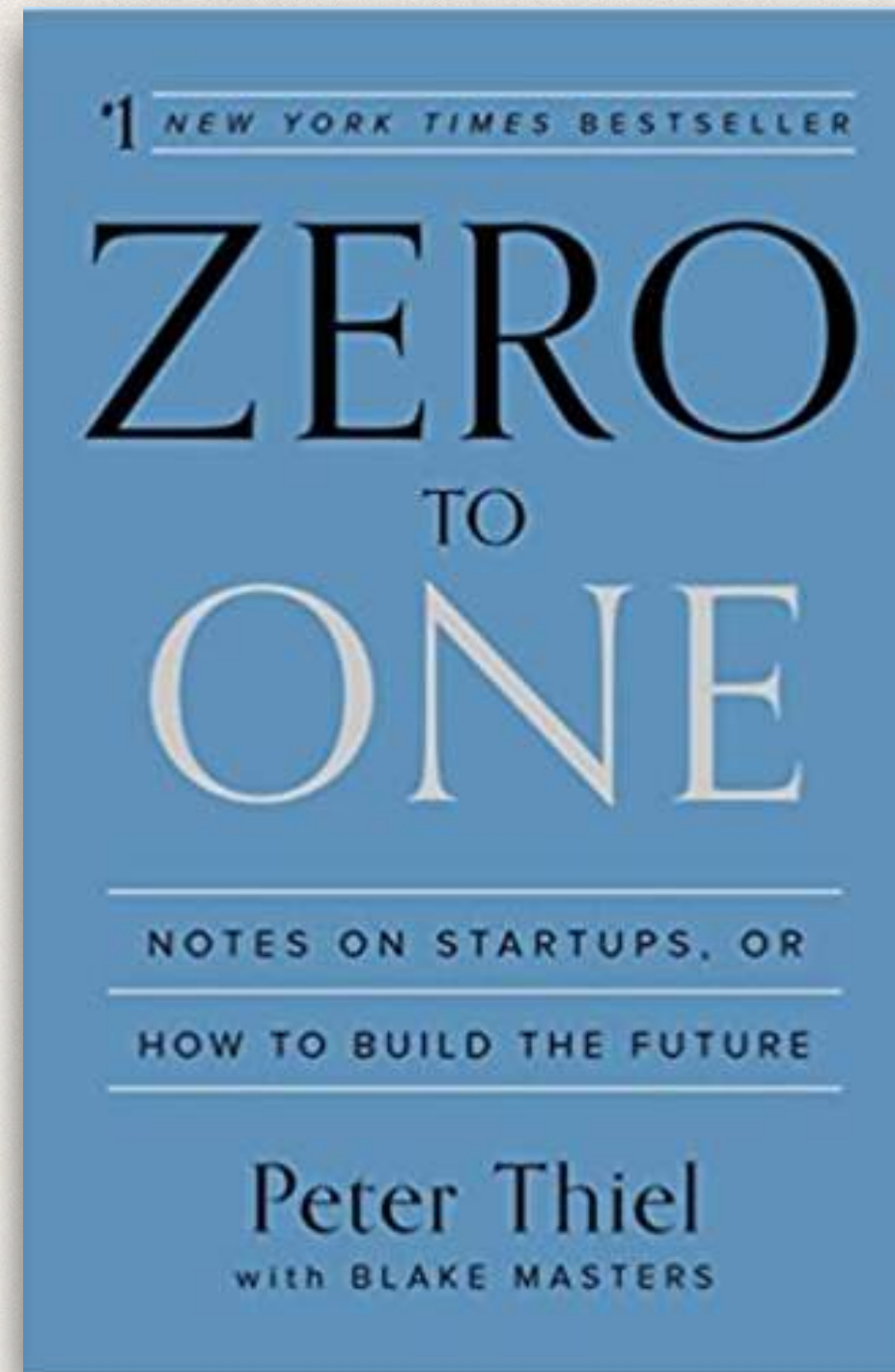

**Currency - September 16, 2014**

**Agent: Chris Parris-Lamb**

Legendary entrepreneur and investor Peter Thiel shows how we can find singular ways to explore still uncharted frontiers and create new inventions

**#1 New York Times bestseller • Sold to Crown Business for seven figures in a heated auction • Huge bestseller in China • Sold in 37 foreign territories • 3+ million sold worldwide**

# Our International Co-Agents

For queries concerning John Grisham and Louise Penny in all territories, please contact Ms. Rebecca Gardner ([rgardner@thegernertco.com](mailto:rgardner@thegernertco.com))

## ***Albanian, Bulgarian, Serbian, Macedonian, Bosnian***

Ms. Mira Droumeva  
Andrew Nurnberg Associates Sofia  
[mira@anas-bg.com](mailto:mira@anas-bg.com)

## ***Chinese, Complex and Simplified***

Ms. Yu-Shiuan Chen  
Bardon-Chinese Media Agency  
[yushiuan@bardonchinese.com](mailto:yushiuan@bardonchinese.com)

## ***Czech, Slovak, Slovene***

Ms. Petra Tobiskova  
Andrew Nurnberg Associates Prague  
[tobiskova@nurnberg.cz](mailto:tobiskova@nurnberg.cz)

## ***Dutch, Flemish***

Ms. Diana Gvozden  
Marianne Schönbach Literary Agency  
[d.gvozden@schonbach.nl](mailto:d.gvozden@schonbach.nl)

## ***Estonian, Latvian, Lithuanian, Ukrainian***

Ms. Tatjana Zoldnere  
Eastern European and Asian Rights Agency  
[zoldnere@earagency.com](mailto:zoldnere@earagency.com)

## ***French***

Ms. Eliane Benisti  
Agence Eliane Benisti  
[eliane@elianebenisti.com](mailto:eliane@elianebenisti.com)

## ***German***

Mr. Christian Dittus & Ms. Antonia Fritz  
Paul & Peter Fritz AG  
[cdittus@fritzagency.com](mailto:cdittus@fritzagency.com), [afritz@fritzagency.com](mailto:afritz@fritzagency.com)

## ***Greek***

Ms. Nike Davarinou – Read n Right Agency  
[nike@readnright.gr](mailto:nike@readnright.gr)

## ***Hebrew***

Ms. Efrat Lev – The Deborah Harris Agency  
[efrat@thedeborahharrisagency.com](mailto:efrat@thedeborahharrisagency.com)

## ***Hungarian, Croatian***

Ms. Judit Hermann  
Andrew Nurnberg Associates Budapest  
[j.hermann@nurnberg.hu](mailto:j.hermann@nurnberg.hu)

## ***Indonesian***

Mr. Santo Manurung – Maxima Creative  
[santo.maxima@gmail.com](mailto:santo.maxima@gmail.com)

## ***Italian***

Ms. Erica Berla – Berla & Griffini Rights Agency  
[berla@bgagency.it](mailto:berla@bgagency.it)

## ***Japanese***

Mr. Ken Mori – Tuttle-Mori Agency, Inc.  
[ken@tuttlemori.com](mailto:ken@tuttlemori.com)

## ***Korean***

Ms. Jackie Yang – Eric Yang Agency  
[jackieyang@eyagency.com](mailto:jackieyang@eyagency.com)

## ***Polish***

Mr. Lukasz Wrobel – Graal Ltd  
[lukasz@graal.com.pl](mailto:lukasz@graal.com.pl)

## ***Portuguese***

Ms. Tassy Barham – Tassy Barham Associates  
[tassy@tassybarham.com](mailto:tassy@tassybarham.com)

## ***Russian***

Ms. Ludmilla Sushkova  
Andrew Nurnberg Associates Moscow  
[sushkova@awax.ru](mailto:sushkova@awax.ru)

## ***Spanish***

Ms. Teresa Vilarrubla – The Foreign Office  
[teresa@theforeignoffice.net](mailto:teresa@theforeignoffice.net)

## ***Swedish, Finnish, Danish, Norwegian, Icelandic***

Ms. Trine Licht – Licht & Burr Literary Agency  
[tl@licht-burr.dk](mailto:tl@licht-burr.dk)

## ***Thai, Vietnamese***

Ms. Sue Yang – Eric Yang Agency  
[sueyang@eyagency.com](mailto:sueyang@eyagency.com)

## ***Turkish***

Mr. Atilla Turgut – Akcali Copyright Agency  
[atilla@akcalicopyright.com](mailto:atilla@akcalicopyright.com)

## ***United Kingdom & British Commonwealth***

Mr. Caspian Dennis - Abner Stein Ltd.  
[caspian@abnerstein.co.uk](mailto:caspian@abnerstein.co.uk)

*For all other markets, contact*

*Rebecca Gardner ([rgardner@thegernertco.com](mailto:rgardner@thegernertco.com))*

*Will Roberts ([wroberts@thegernertco.com](mailto:wroberts@thegernertco.com))*